



**Viridi™**

# Installation, Operation and Maintenance Manual



## SBR30-150

(9920-00022)

**BATTERY ENERGY STORAGE SYSTEM (BESS)**

Revision C: 25-MAR-2026

# Contents

- Contents ..... 1
- 1. Notice ..... 6
- 2. Safety ..... 8
  - 2.1 Warnings, Cautions, and Important Notes ..... 8
  - 2.2 Battery Precautions ..... 10
  - 2.3 Disposal and Recycling ..... 10
  - 2.4 Emergency Response ..... 11
    - 2.4.1 Scenario-Based Emergency Response Considerations for Mobile Deployment ..... 11
- 3. Product Details ..... 15
  - 3.1 Overview ..... 15
  - 3.2 Features ..... 15
  - 3.3 System Components ..... 17
    - 3.3.1 Rear View (with callouts) ..... 17
    - 3.3.2 Side View (with callouts) ..... 18
    - 3.3.3 Isometric View (with callouts) ..... 19
    - 3.3.4 Inside View (with callouts) ..... 20
  - 3.4 Environmental ..... 21
  - 3.5 Electrical ..... 21
- 4. Installation ..... 23
  - 4.1 Location Considerations ..... 23
  - 4.2 Handling and Transport ..... 23
  - 4.3 Loading for Transport ..... 24
    - 4.3.1 SBR30 / Trailer Separation ..... 25
      - 4.3.1.1 Pictorial Representation of SBR30 / Trailer Separation ..... 25
    - 4.3.2 Transport Configuration ..... 25
      - 4.3.2.1 Transport Configuration Pictorial Representation (typical) ..... 26
- 5. Operation: Overview ..... 27
  - 5.1 Displays ..... 27
  - 5.2 Connections ..... 28
  - 5.3 Controls ..... 29



- 5.4 User Interface ..... 30
- 6. Operation: Information / Settings Screens ..... 32
  - 6.1 Overview ..... 32
  - 6.2 Status ..... 33
  - 6.3 Extended Status Screens ..... 33
  - 6.4 Setpoints ..... 34
  - 6.5 Generator Settings ..... 35
    - 6.5.1 Displays ..... 35
    - 6.5.2 Generator Hybrid Time of Day Settings ..... 36
  - 6.6 ON\_GRID Charge Programs ..... 37
  - 6.7 Alarms ..... 38
  - 6.8 Manual Functions ..... 39
  - 6.9 Machine Options ..... 40
    - 6.9.1 USER INPUTS ..... 40
- 7. ViSTA ..... 42
  - 7.1 Logging In ..... 42
  - 7.2 ViSTA Notifications ..... 43
  - 7.3 ViSTA Dashboard ..... 43
    - 7.3.1 Device Identification and Overview ..... 44
    - 7.3.2 The Map ..... 44
    - 7.3.3 Alarms ..... 45
    - 7.3.4 The Diagram ..... 46
    - 7.3.5 More Detailed Telematics ..... 47
    - 7.3.6 Data Over Time ..... 47
- 8. Operating Modes ..... 48
  - 8.1 Powering ON the SBR30 ..... 48
    - 8.1.1 On-Grid Charging Installation and Operation ..... 50
  - 8.2 Off-Grid Discharge Installation & Operation ..... 55
    - 8.2.1 Setup ..... 55
    - 8.2.2 Select Mode ..... 57
    - 8.2.3 Confirm Output Voltage ..... 57



- 8.2.4 Confirm Load Voltage ..... 57
- 8.2.5 Verify Operation ..... 58
- 8.3 Generator Hybrid Installation ..... 59
- 8.4 Generator Hybrid Operation ..... 62
  - 8.4.1 Turn on the SBR30 (See powering on the SBR30)..... 62
  - 8.4.2 Select Mode ..... 62
  - 8.4.3 Confirm Output Voltage ..... 62
  - 8.4.4 Confirm Load Voltage ..... 62
  - 8.4.5 Input Generator Size ..... 63
  - 8.4.6 Input Generator KW ..... 63
  - 8.4.7 Accept Generator Size ..... 63
  - 8.4.8 Generator Hybrid Mode ..... 64
  - 8.4.9 Verify Operation ..... 64
- 8.5 Microgrid Installation ..... 65
  - 8.5.1 Step by step physical set up of the microgrid following the wiring diagram ..... 65
  - 8.5.2 Physical Set Up ..... 69
- 8.6 Microgrid Operation ..... 70
  - 8.6.1 How to start the Microgrid ..... 70
  - 8.6.2 How to verify functionality on HMI ..... 71
  - 8.6.3 Servicing/Removing a BESS ..... 72
- 8.7 Powering Off ..... 73
- 9. Maintenance ..... 75
  - 9.1 Cleaning ..... 75
  - 9.2 Maintenance Schedule ..... 76
    - 9.2.1 14-Day Service Interval Checklist ..... 76
    - 9.2.2 3-month Service Interval Checklist ..... 76
  - 9.3 Medium Ambient Filter Change ..... 77
  - 9.4 Troubleshooting ..... 78
  - 9.5 Trailer ..... 78
    - 9.5.1 Warnings ..... 78
    - 9.5.2 Periodic Maintenance Checks ..... 79



9.5.3 Trailer Contact information ..... 80

9.6 ViSTA Alarm Definition Glossary .....81

9.7 Alarms.....82

9.8 Contact Viridi Customer Service .....85

10. Appendix .....86





# 1. Notice

As an express condition of Viridi's warranty and to encourage utilization of industry best practices, Viridi requires that the installation, mobilization, and operation of the SBR30 only be completed by, or at the direction of, a qualified professional as defined by the jurisdiction(s) within which the installation, mobilization, and operation occurs. Specific applications can vary, so please direct specific questions to the following Viridi Contacts:

- Sales: 716-968-8658; email [sales@viridiparente.com](mailto:sales@viridiparente.com)
- Service: 866-984-7434; [service@viridiparente.com](mailto:service@viridiparente.com)

Viridi expressly disclaims liability for applications made in a manner inconsistent with this guide and/or in non-compliance with local building and electrical codes. This Installation, Operations & Maintenance Manual, incorporates all the terms and conditions of sale. All information provided in this manual is subject to change with or without notice.

Please refer to the warranty documents provided at the point-of-sales for further information.

# SAFETY



## 2. Safety

To make the best and proper use of the SBR30, all personnel handling or operating the SBR30 are advised to follow these guidelines:

Only fully trained and qualified personnel should operate or service the machine. Read and understand the Installation, Operations & Maintenance Manual before operating the equipment to make certain you follow safe practices, including service and maintenance intervals.

If there is a defect or evidence of damage that might expose an employee to injury, the defective or damaged SBR30 shall be removed from service, and no employee may use it until repairs and tests needed to render the equipment safe have been made.

Always keep this Installation, Operations & Maintenance Manual in a convenient place for easy access.

If this Installation, Operations & Maintenance Manual is lost or damaged, order a new one from Viridi Parente, Inc., referencing your equipment serial or asset number.

This Installation, Operations & Maintenance Manual, should be considered part of the SBR30 and remain with it. Constant efforts are made to improve the quality and performance of our products; it may be that some information in the User Manual differs from your equipment. If any questions arise, please contact Viridi Parente, Inc.

All the information in this publication is based on the latest product information available at the time of printing. Viridi Parente, Inc. reserves the right to make changes to this Installation, Operations & Maintenance Manual, without notice or obligation.

No part of this publication may be reproduced or copied without prior written permission from Viridi Parente, Inc. Additional fire protection is managed through the SBR30 telecom's device and ViSTA notification system. This system is programmed to send notifications to authorized users in the event of any abnormal functioning or temperature deviation so that immediate appropriate action can be taken. It is recommended that all Viridi BESS be operated with the ViSTA notification system.

### 2.1 Warnings, Cautions, and Important Notes



This "Safety Alert" symbol and others like it are in place to warn the operator of potential hazards. It means attention/become alert – your safety is involved!

This symbol can signify DANGER and, where used, documents a WARNING or CAUTION which is followed by text highlighting the potential hazard. This manual will detail the potential hazards so that you can take the necessary precaution(s) towards ensuring operator and equipment safety.

**A WARNING** signifies a situation whereby the operator, members of staff, or the public could be put in danger of personal injury by the improper operation of the SBR30.

**A CAUTION** signifies a situation whereby damage to the SBR30 or associated parts could be caused by improper operation of the SBR30.

#### Symbols Used Within This Manual

	Warning		Wear Gloves
	Shock Hazard		Quality
	General Safety		Tip

## General Precautions



**COMPETENT PERSONNEL:** The SBR30 is intended for use by suitable qualified, trained, and competent personnel who have read and understand this manual and are familiar with the equipment and its intended use. A certain level of user competence is assumed when operating power generating equipment.



**READ AND UNDERSTAND:** Before personnel operate, service, or perform tasks on the equipment, the manual must be read and understood.



**VENTILATION:** Do not obstruct the air vents and allow adequate space around the SBR30 for ventilation.



**EARTH CONNECTION:** The SBR30 requires a connection to an earth system. The SBR30 must always be connected to an external earth system.



**DO NOT PRESSURE WASH:** The SBR30 is NEMA 3R rated, it is NOT protected against hose directed water.



**PRECAUTIONS:** Follow the precautions listed within this manual before operation and during operation, service, and maintenance activities for the safety of yourself and others and to protect the performance of the equipment.



**WARNING LABELS:** Keep warning and caution labels from becoming dirty or torn and replace them if they become damaged. Replacements can be obtained by contacting Viridi Parente, Inc.



**SAFETY:** Safety is an utmost concern. Safety statements are one of the primary ways to call attention to potential hazards associated with generator operations.

## Warnings



**CRUSH HAZARD:** The SBR30 is a crush hazard when elevated above ground level, and the area below the SBR30 should be cleared before hoisting the SBR30 above ground level.



**ELECTROCUTION HAZARD:** The generator earth connection must be connected to a suitable earth point either on the equipment to which it is installed, to a recognized earth point on a building, or to an earth spike correctly installed in the ground. Correct earth bonding is an essential safety requirement of the BESS.



**HEAVY ITEM:** The SBR30 is heavy; care must be taken when handling the SBR30 to avoid injury.



**DANGER OF FALLING:** Do not stand on top of the SBR30. The surface may be slippery.



**TRIP HAZARD:** Take care not to trip over exposed cables in the area around the SBR30. Install road plates to cover exposed cables where necessary.

















**SHOCK HAZARD:** Authorized access only. Do not remove panels to access internal components of the SBR30. There are no user-serviceable parts inside the SBR30. Only qualified, competent personnel are permitted to service internal components. Unauthorized Persons attempting to do so will be at risk of electric shock.

To prevent the risk of electric shock, Arc Flash, or equipment damage, ensure that the system is completely de-energized and all power sources are fully disconnected before performing any internal maintenance on the Battery Energy Storage System (BESS). This includes:



- Confirming that the key switch and 24v disconnect are in the **OFF** position.
- Ensuring that all breakers, including those on the BESS system and common bus (if applicable), are in the **open (OFF)** position.
- Verifying that all incoming and outgoing power sources are disconnected/unplugged.

### Cautions

	Do not allow cable connections to lie in or under water.
	Do not allow connectors to drop or to be dragged across hard surfaces.
	Make sure that dust caps are fitted when not in use.
	Do not apply tension to connectors.
	Do not connect leads together when reeling them in.
	Do not make or break connections when carrying load
	Verify that the SBR30 is set up at least 10 feet away from exposure and means of egress
	3 foot minimum from other ESS
	50 foot minimum from public seating areas and from tents, canopies, and membrane structures with an occupant load of 30 or more.
	The SBR30 has a maximum power capacity of 30 KW. Do not attempt to exceed the stated maximum power capacity.
	The SBR30's Dielectric Withstand Test Voltage is 1960Vac
Charging the SBR30 is prohibited in the following locations:	
	<ul style="list-style-type: none"> <li>• Indoors</li> <li>• Rooftops</li> <li>• Parking Garages</li> <li>• Within 10 feet of exposures and egress</li> <li>• Within 10 feet of combustible vegetation/material.</li> <li>• Within 50 feet public seating areas with an occupant load of 30 or more.</li> </ul>
	Charging is permitted near single trees, shrubbery, or cultivated ground if it does not have a means of transmitting fire.
	Units in transit from the charging or storage location to the deployment location shall not be parked within 100 feet of an occupied building for more than 1 hour during transit without approval from the local Authority Having Jurisdiction (AHJ).

## 2.2 Battery Precautions

The chemicals and materials in the battery are stored in a sealed container, designed to withstand temperatures and pressures encountered during normal use. As a result, during normal use, there is no physical danger of ignition, explosion, or hazardous material leakage. There is only a risk of exposure if a battery is mechanically, thermally, or electrically abused. There is no user access to the batteries. Do not remove panels.

## 2.3 Disposal and Recycling

The SBR30 comprises components that must be disposed of responsibly. Many of the components can be reused or recycled. For advice on the safe and proper disposal of SBR30, please contact your Viridi sales representative. Viridi Parente, Inc. partners with American Battery Technology Company to disassemble end of life battery cells into critical minerals to be reused.

## 2.4 Emergency Response

The SBR30 includes internal fault mechanisms designed to prevent failures and subsequent risk hazards. However, Viridi cannot guarantee safety performance of the SBR30 if the equipment is exposed to abuse, damage, or negligence.

If an installer or user happens to be exposed to the internal materials of the battery cell due to damage on the outer casing, the following actions are recommended:

- In Case of Inhalation: Leave the contaminated area immediately and seek medical attention.
- In Case of Skin Contact: Wash the contacted area thoroughly with soap and seek medical attention.
- In Case of Ingestion: Induce vomiting and seek medical attention.

If a fire breaks out at or near the location of the SBR30, perform the following counter measures:

- In the event of a fire, appropriate extinguishing media should be used based on the type of incident. For battery-related fires, the system should be allowed to burn itself out while defensive firefighting strategies are employed to protect nearby exposures, if necessary. For non-battery-related fires, such as those occurring near an SBR30 unit, suitable extinguishing agents, including water or an ABC fire extinguisher, should be utilized. Additionally, if a fire occurs adjacent to the SBR30, water may be applied as a defensive measure to cool the unit, if deemed necessary.

Follow the proper fire-fighting instructions. If a fire occurs when charging the SBR30, provided it is safe to do so, disconnect the battery pack circuit breaker to shut off the power charge. If the battery pack is not on fire, extinguish the fire before the battery pack catches fire, preferably with water. If the battery pack within the SBR30 is on fire, do not try to extinguish it, and evacuate people from the premises immediately.



- **WARNING:** Explosion is possible if the battery pack within the SBR30 experiences temperatures above 150°C (302°F). When a battery pack is burning, it will produce poisonous gases. Do not approach it.
- To deal with an accident with the SBR30 on land, refer to the site-specific emergency response plan, if possible, and move the damaged SBR30 to a segregated location and call your local fire department or service engineer. Service inspection must be completed by Viridi or an authorized service center before the unit can be cleared for operation. Note that proper lockout/tagout procedures must be followed in such cases. To deal with an accident with the SBR30 in the water, stay out of the water and do not touch anything if any part of the battery, inverter, or wiring is submerged. Do not use the submerged battery again.
- Contact your Viridi Service Team for assistance at:
  - Customer Support Line: 1-866-984-7434
  - Email: [service@viridiparente.com](mailto:service@viridiparente.com)

### 2.4.1 Scenario-Based Emergency Response Considerations for Mobile Deployment

The SBR30 is a mobile battery energy storage system intended for deployment at temporary or variable locations where site-specific emergency response plans may not be available at the time of permitting. In recognition of this, the following representative deployment scenarios are provided to demonstrate how emergency response considerations may vary by context while maintaining consistent hazard controls, system safeguards, and coordination with emergency responders.

These scenarios are illustrative only and do not replace the authority or operational discretion of the Fire Department. In all cases, emergency response actions shall align with Section 2.4 of this Emergency Response Plan and applicable codes and standards.

➤ **Scenario A: Streetside or Curbside Deployment (Public Right-of-Way)**

**Description:**

The SBR30 is deployed adjacent to a roadway or curb within a public right-of-way to provide temporary electrical power support.

**Primary Considerations:**

- Presence of vehicular traffic and pedestrians
- Limited standoff distances due to urban constraints
- Need for clear access for emergency responders

**Emergency Response Considerations:**

- In the event of a fire or suspected battery incident, occupants and bystanders shall be directed to evacuate the immediate area in accordance with applicable codes and responder instructions.
- If safe to do so, the external emergency stop (E-stop) located on the exterior of the enclosure may be activated to electrically isolate the system.
- Firefighting response shall follow a defensive strategy consistent with Section 2.4, prioritizing protection of exposures and responder safety.
- Cooling water may be applied defensively to the exterior of the unit if deemed necessary by responding fire department personnel.
- Traffic control, scene management, and suppression tactics remain under the authority of the responding fire department.

➤ **Scenario B: Public Event or Temporary Assembly Deployment (e.g., Concert, Festival, Civic Event)**

**Description:**

The SBR30 is deployed to support temporary electrical loads associated with a public event or temporary assembly, such as a concert, festival, or civic gathering, where members of the public may be present in proximity to the unit.

**Primary Considerations:**

- Increased density of occupants and bystanders
- Elevated sensitivity to life safety and crowd management
- Need for rapid coordination with emergency responders

**Emergency Response Considerations:**

- In the event of a fire, thermal event, or suspected battery malfunction, immediate evacuation of the area surrounding the SBR30 shall be initiated in coordination with event staff and emergency responders.
- If safe to do so, the external emergency stop (E-stop) located on the exterior of the enclosure may be activated to electrically isolate the system.
- Firefighting response shall follow a defensive strategy consistent with Section 2.4, with priority given to life safety, crowd separation, and protection of nearby exposures.
- Water may be applied defensively to the exterior of the unit to limit heat transfer if deemed appropriate by responding fire department personnel.
- Scene control, evacuation distances, and suppression tactics remain under the authority of the responding fire department.

➤ **Scenario C: Unattended or Overnight Deployment**

**Description:**

The SBR30 is deployed in a location where it may be unattended for extended periods, including overnight operation.

**Primary Considerations:**

- Delayed human detection of an abnormal condition
- Reliance on internal system protections and alarms
- Importance of responder safety upon arrival

**Emergency Response Considerations:**

- The SBR30 incorporates internal fault detection and protective mechanisms designed to limit escalation in the event of abnormal operation.
- Upon arrival, emergency responders shall be informed that the unit may be energized and that lithium-ion battery hazards may be present.
- The external E-stop provides a means of electrical isolation without opening the enclosure, if responders determine it is safe and appropriate to do so.
- If a battery pack is involved in fire, no suppression shall be attempted, and the incident shall be managed defensively with evacuation and exposure protection as outlined in Section 2.4.
- Following any unattended incident, the unit shall remain out of service until inspected and cleared by Viridi or an authorized service center.

➤ **General Notes Applicable to All Scenarios**

- Emergency response actions shall always prioritize life safety and responder safety.
- Firefighting tactics, evacuation distances, and scene control remain at the discretion of the responding fire department.
- This scenario-based guidance is intended to supplement, not replace, site-specific emergency response planning where such plans are available.

# PRODUCT DETAILS



## 3. Product Details

### 3.1 Overview

Welcome to the SBR30, the commercial-scale Lithium-Ion Battery Energy Storage System (BESS) built to deliver Fail-Safe power in the most rugged conditions.

Viridi's core value lies in our unique, bottom-up approach to safety. Viridi's RPS50 battery packs contain technology to contain cell-to-cell thermal runaway, halting events before the release of sparks, smoke, or fire. Rather than relying on active electronic or mechanical components (common points of failure in an emergency) this passive system is built into the architecture of every RPS50 battery pack.

Packs are controlled by an advanced Battery Management System (BMS) and sealed in an industrial grade ¼" steel shell. Packs are connected to the Power Control System (PCS) comprising a UL-listed bi-directional storage inverter, Industrial PLC for additional unit level control and safety, and Viridi IoT Solution for real time monitoring and control. This design approach represents the highest safety standard available in a commercial BESS.

SBR30 can operate on-grid to optimize facility energy use, or off-grid to drastically reduce reliance on (or eliminate) diesel generation, fuel spend, and CO<sub>2</sub> emissions.

### 3.2 Features

#### Key Benefits

- Zero emissions
- On-Grid Charging
- Off-Grid Discharging
- On-Grid Discharging
- Generator Hybridization Operation
- Micro-Grid Forming & Participation
- Minimal Noise

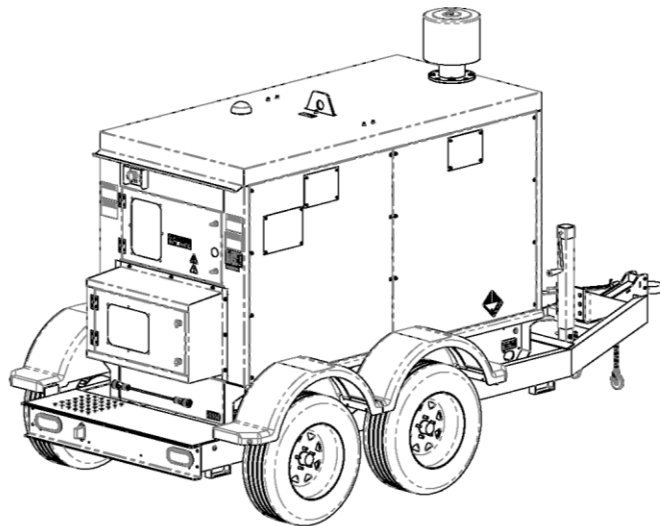

#### Physical Parameters

- SBR30 Length (excluding trailer) 100.7 in
- SBR30 Width (excluding trailer) 44.8 in
- SBR30 Height (excluding trailer) 65.4 in
- SBR30 Skid Mounted Unit Weight 5,750 lbs.
- Trailer Mounted Weight 7,000 lbs.

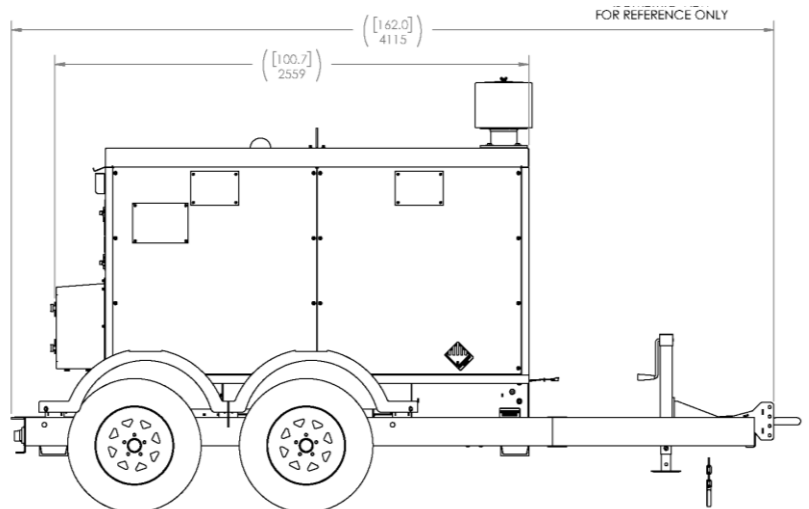
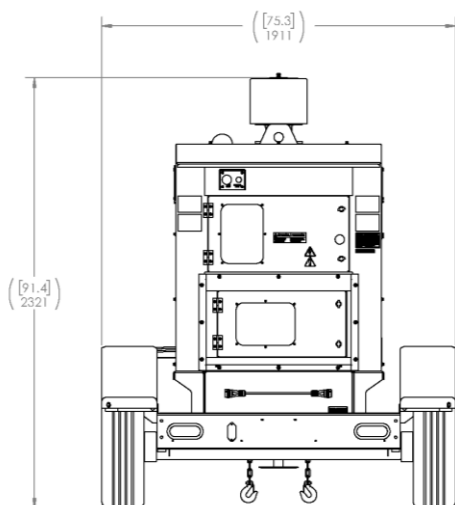

## Discharge Parameters<sup>1</sup>

- Minimum to maximum operating temperature: -10°C to 45°C (14°F to 113°F)
- Max continuous power: 30 kW

## Charge Parameters<sup>2</sup>

- Minimum to maximum operating temperature: -10°C to 45°C (14°F to 113°F)
- Max continuous power: 30 kW

## Electrical Features

Up to 150 Amp pass-through Capability

- 1 X NEMA 14-50R  
1Phase-208VAC, 50A
- 2 X CS Twist Lock Receptacles  
1Phase-208VAC, 50A
- 2 X NEMA 5-20R  
1 Phase-110VAC, 20A
- 2 X AC Cam-Locks SWITCHABLE  
3 Phase-208VAC, 80A /or/ 3P-480VAC, 40A

## Mechanical Features

- Skid-Based Design Compatible with Towable Trailers
- Side-Access Forklift Pockets
- Single Top Lift Point
- Full Custom Enclosure 44 in x 50 in x 100 in

## Paralleling Operations

- Parallel with other SBR30 units
- Parallel with other “DEIF” controller paralleling generators
- Total paralleling capability of up to 16 systems for 480 kW of power and 2.4 MWh of nominal capacity

## Performance

- **Maximum Continuous Power**
  - 30 KW Charge
  - 30 KW Discharge
- **Battery System**
  - 146.7 KWh Nominal
  - 132 KWh Usable
  - 3,000 Cycles at Usable Capacity<sup>3</sup>

## Certifications

- UN 38.3 (cell, module)
- UL 1642 (cell) UL Recognized Component
- UL 1741 (inverter) cTÜV SÜDus Listed
- IEEE 1547 (inverter) cTÜV SÜDus
- UL 1973 (pack) cTÜVus Listed
- UL 2580 (cell) UL Recognized Component
- UL 9540A (cell/module/pack tested)
- UL 9540 (ESS) cETLus Listed

**Recycling Partner:** American Battery Technology Company disassembles end of life battery cells into critical minerals to be reused/recycled.

<sup>1</sup> Operating temperature range mirrors battery cell specifications. The Battery Management System (BMS) is programmed to manage the pack utilization rate to control the internal pack thermal conditions and prevent operation outside of pack interior temperature limits, which can be tailored for different applications/installations. The BMS communicates applicable operating conditions continuously via CAN bus to the inverter and/or system controller.

<sup>2</sup> Optimal minimum to maximum charge operating temperature: 0°C to 40° C. For charging below -0°C maximum charge rate: 13.8 KW.

<sup>3</sup> Cycle life can be optimized for individual applications and operating conditions (depth of discharge, duty cycle, temperature, charge/discharge rate).

### 3.3 System Components

#### 3.3.1 Rear View (with callouts)

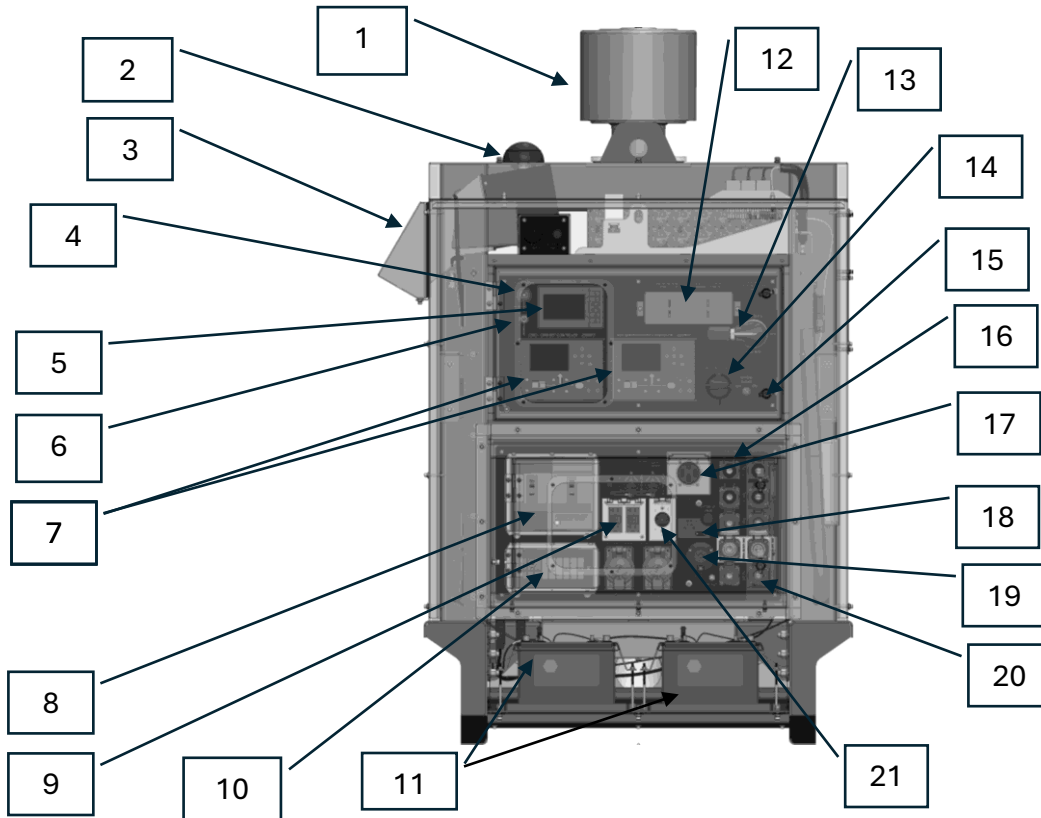

Component List – Front View

Item	Component – Front View	Part No.	Item	Component – Front View	Part No.
1	Intake Filter Housing	2410-00036	12	50A and 100A Circuit Breaker	50A, 2400-00177 100A, 2400-00179
2	Antenna (WIFI & LTE)	1900-00065	13	Transfer Switch	4100-00049
3	Exhaust Hood	6500-01109	14	24 V Disconnect Switch	2400-00099
4	DEIF USB Programming Port	1900-00145	15	Key Switch	2400-000141
5	HMI	2740-00018	16	Load / Grid Cam Locks	3000-00441-5
6	System ModBus Programming Port	1900-00143	17	50A, 250 VAC Outlet	3000-00430
7	DEIF	1900-00079	18	2 Wire Remote Start	1900-00094
8	150A Circuit Breaker	2400-00181	19	NOCO Trickle Charger GCP1 15A AC Port Plug	1900-00096
9	GFIC 20A, 125V Outlet	3000-00427	20	AUX/GEN Cam Locks	3000-00520-4
10	20A, 30A, and 50A Circuit Breaker (outlets)	20A, 2400-00170 30A, 2400-00171 50A, 2400-00172	21	30A, 125Vac Outlet	3000-00428
11	Battery, 12V, Group 34 AGM, 750A, NAPA	1900-00088			

3.3.2 Side View (with callouts)

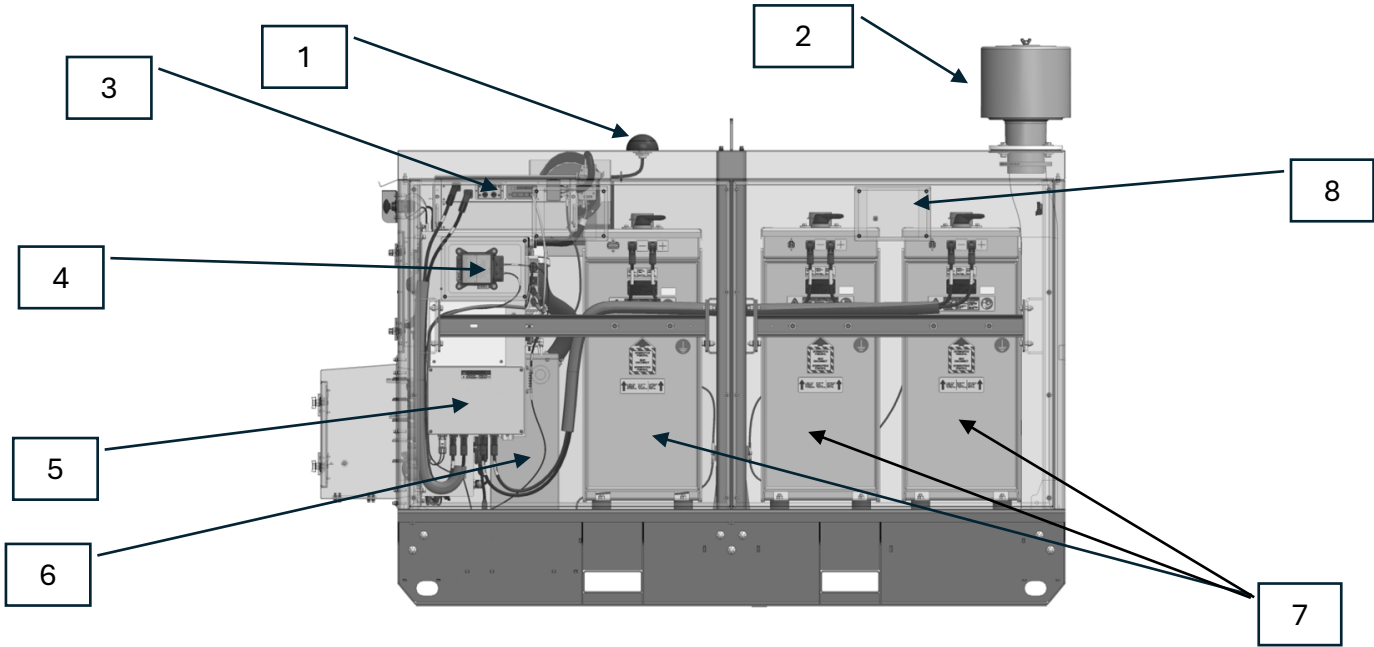

Component List – Side View

Item	Component	Part No.
1	Antenna (WIFI & LTE)	1900-00065
2	Intake Filter Housing	2410-00036
3	Inverter	2770-00018
4	LV PDU	2400-00127
5	High Voltage PDU	6500-00440
6	Transformer	1900-0062
7	Viridi RPS-50 Lithium-Ion Batteries (qty=3)	N/A
8	High Velocity Fan	2400-00021

3.3.3 Isometric View (with callouts)

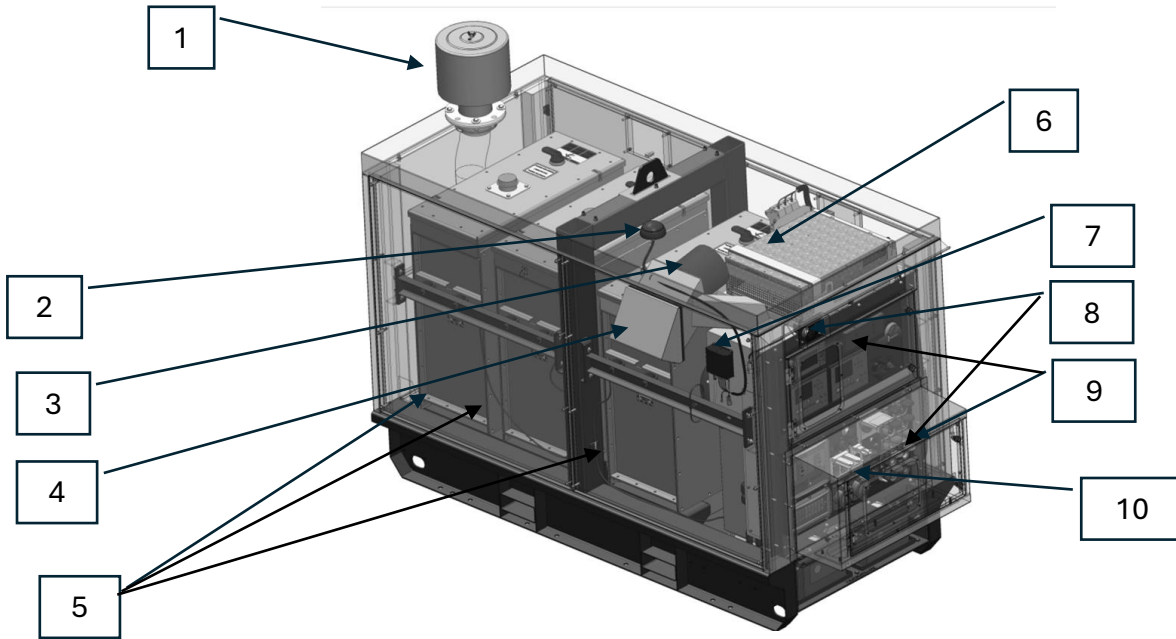

Component List – Isometric View

Item	Component	Part No.
1	Intake Filter Housing	2410-00036
2	Antenna (WIFI & LTE)	1900-00065
3	Exhaust Fan	2410-00041
4	Exhaust Hood	6500-01109
5	Viridi RPS-50 Lithium-Ion Batteries (qty=3)	N/A
6	Inverter	2770-00018
7	VCom Assembly	6500-00884
8	E-Stop (qty=2)	1900-00103
9	System Live Indicator Lights (qty=2)	1900-00106
10	Receptacle, 50A Twist Lock, 3P, 4W, CS6369	3000-00426

### 3.3.4 Inside View (with callouts)

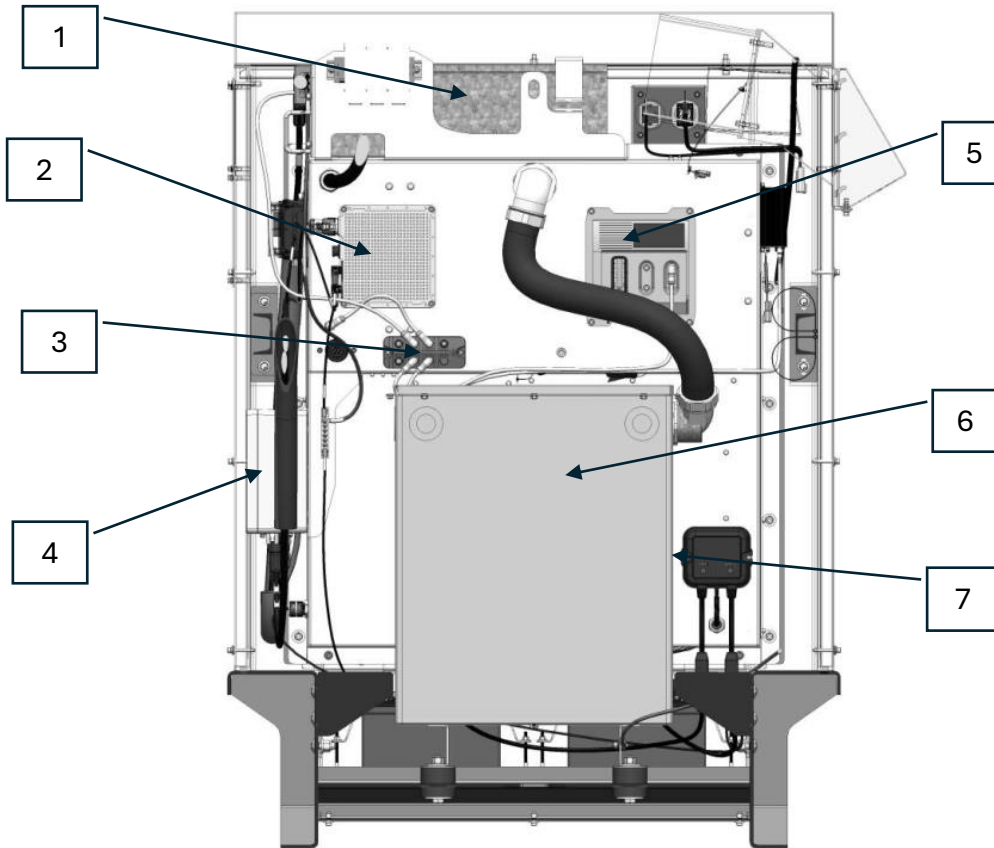

**Component List – Inside View**

Item	Component	Part No.
1	Inverter	2770-00018
2	DC/DC Converter	2760-00043
3	Ethernet Switch	2400-00137
4	High Voltage PDU	6500-00440
5	PLC	1900-00083
6	Transformer	1900-00062
7	NOCO Trickle Charger	6500-00628

### 3.4 Environmental

The SBR30 is intended for outdoor use in a wide range of environments. It has a NEMA 3R rating suitable for outdoor use in rain, sleet, and icy conditions. It operates in a temperature range from 14° F to 113° F (-10° C to +45° C). However, it should not be submerged in water or exposed to direct sunlight at elevated temperatures.

### 3.5 Electrical

Three RPS50 batteries, producing a nominal 600VDC, connect to an inverter. The inverter output is 480VAC (max 30 KW), which feeds 480V to the CAMLOCKS or a transformer supplying 208V to CAMLOCKS and six AC outlets.

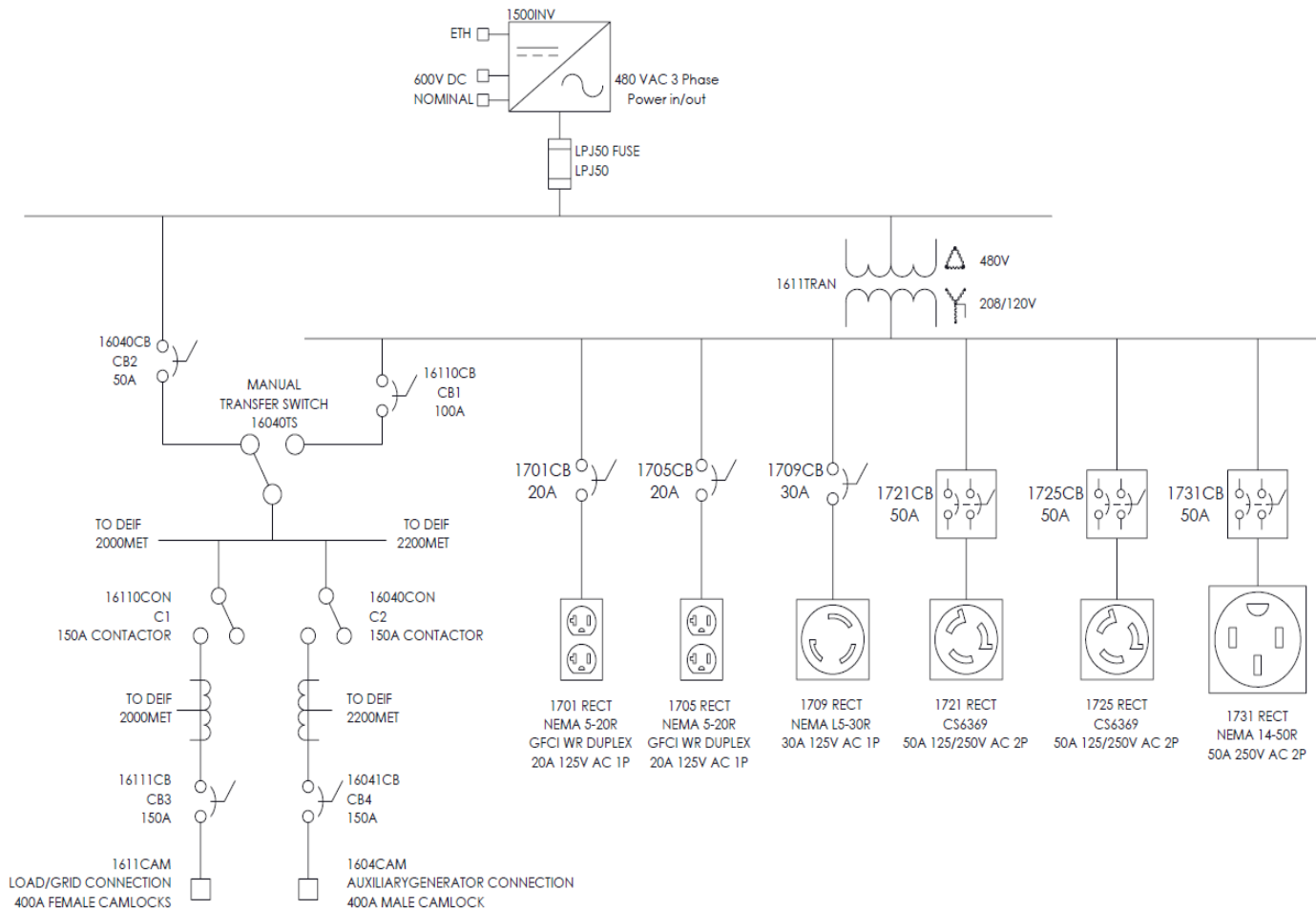

Single Line Electrical System Diagram

# INSTALLATION & OPERATION



## 4. Installation

### 4.1 Location Considerations

Determine the necessary size of energy storage/back-up system for your application. Different project sites require different kWh of energy storage and back-up.



**Submit designs and plans to appropriate authorities for review.** Before beginning installation or utilization, permits and inspections must be obtained in accordance with local laws and regulations, as necessary.



**Coordinate SBR30 site delivery and installation.** The SBR30 is heavy and must be installed with proper equipment. The SBR30 must be installed according to the design plans below.

To decommission or uninstall the SBR30, please contact your Viridi service team for further instructions. This must be completed by Qualified Personnel, SBR30 and any disposal of components requires compliance with local laws, rules, and regulations. Viridi encourages recycling of all materials where possible and works with the American Battery Technology Company to recover lithium-ion battery components.

Required equipment, tools, and other items depend on the final consumer and installation location. Consult your service engineer and local installer for further instruction.

### 4.2 Handling and Transport

#### General Considerations



Do not expose the SBR30 to an open flame.



Do not place or store the SBR30 near highly flammable materials.



Do not expose or place near water sources such as downspouts or sprinklers.



Do not install the SBR30 in an air-tight enclosure or in an area without ventilation.



Store the SBR30 on a flat, level surface in a cool, dry location.



Store the SBR30 out of reach of children and animals.



Do not disconnect, disassemble, or repair the SBR30 with unqualified personnel. Only Qualified Personnel should handle, install, and service the SBR30



Do not drop, deform, impact, cut, or penetrate the SBR30 with a sharp object. Doing so may cause a fire or leakage of electrolytes.



Do not step on or stand on the SBR30 or its packaging.



Do not place any objects on top of the SBR30.



Do not charge or discharge the SBR30 if damaged or if the device is malfunctioning.



Install the SBR30 with proper clearance from vehicles.



The SBR30 has a NEMA 3R rating, which provides protection from falling rain, dirt, and sleet and will be undamaged by the external formation of ice on the enclosure. Do not hose down the SBR30 or pressure wash, as it is not rated for hose directed water.



All units must be transported in compliance with 49 CFR 171-180, Pipeline and Hazardous Materials Safety Administration (PHMSA) Hazardous Materials Regulations, and UN38.3.



Specific to ESS units transported within New York City, the movement of vehicles carrying hazardous materials is additionally subject to the New York City Fire Code (FC 2701–2707) and the New York City Department of Transportation (NYC DOT) Hazardous Materials Transportation Regulations.



Compliance includes, but is not limited to:

- Use of designated New York City hazmat routes.
- Tunnel restrictions prohibiting most lithium battery shipments.
- Required vehicle placarding per 49 CFR
- No stopping/standing except in designated areas.
- Driver HazMat endorsement and required training
- Time-of-day restrictions, when applicable

### 4.3 Loading for Transport

The following methods are available for loading the SBR30 in preparation for transport:

- **Lifting and Loading**
  - Lifting and unpacking guidelines will depend on the final consumer and local installation parameters. Follow established workplace safety guidelines and procedures when receiving, handling, transporting, unpacking, lifting, and installing the SBR30.
- **Overhead Lift Point**
  - The SBR30 can be lifted using a crane from the designated center lifting point.
  - Ensure the crane is rated for the full weight of the unit, whether trailered or untrailered.
- **Forklift Pockets (non-trailer mounted units)**
  - Use a forklift or telehandler rated for loads exceeding **6,000 lbs.**
  - Insert forks fully into the designated fork pockets before lifting.
- **Ball Hitch Forklift Attachment (trailer mounted units)**
  - Recommended method for dock loading.
  - Attach a fork truck hitch to the trailer tongue, then carefully drive the unit from the dock onto the truck.
- **Lifting a Trailered Unit with Forklift**
  - Use a forklift or telehandler rated for loads exceeding **7,000 lbs.**
  - Position the forks so that one fork is between the trailer tires, closer to the front, and the other fork is positioned just outside the rear tire along the trailer tongue.
- **Mechanical Tie-Downs**
  - Reference figure in paragraph 4.3.2.1 for suggested loading configuration
  - Loading, weight distribution and tie down is at the discretion of the driver and local, state and federal highway requirements
- **Post Unloading Inspection:**
  - Upon receipt of the SBR30 inspect the unit for any major damage that might have been incurred as part of the shipping process.
  - In the event that a RPS50 battery within the SBR30 is damaged during transport the battery will be shut off by the main contactor and the battery will not turn ON. If this is the case, please contact Viridi for support.

### 4.3.1 SBR30 / Trailer Separation

#### 4.3.1.1 Pictorial Representation of SBR30 / Trailer Separation

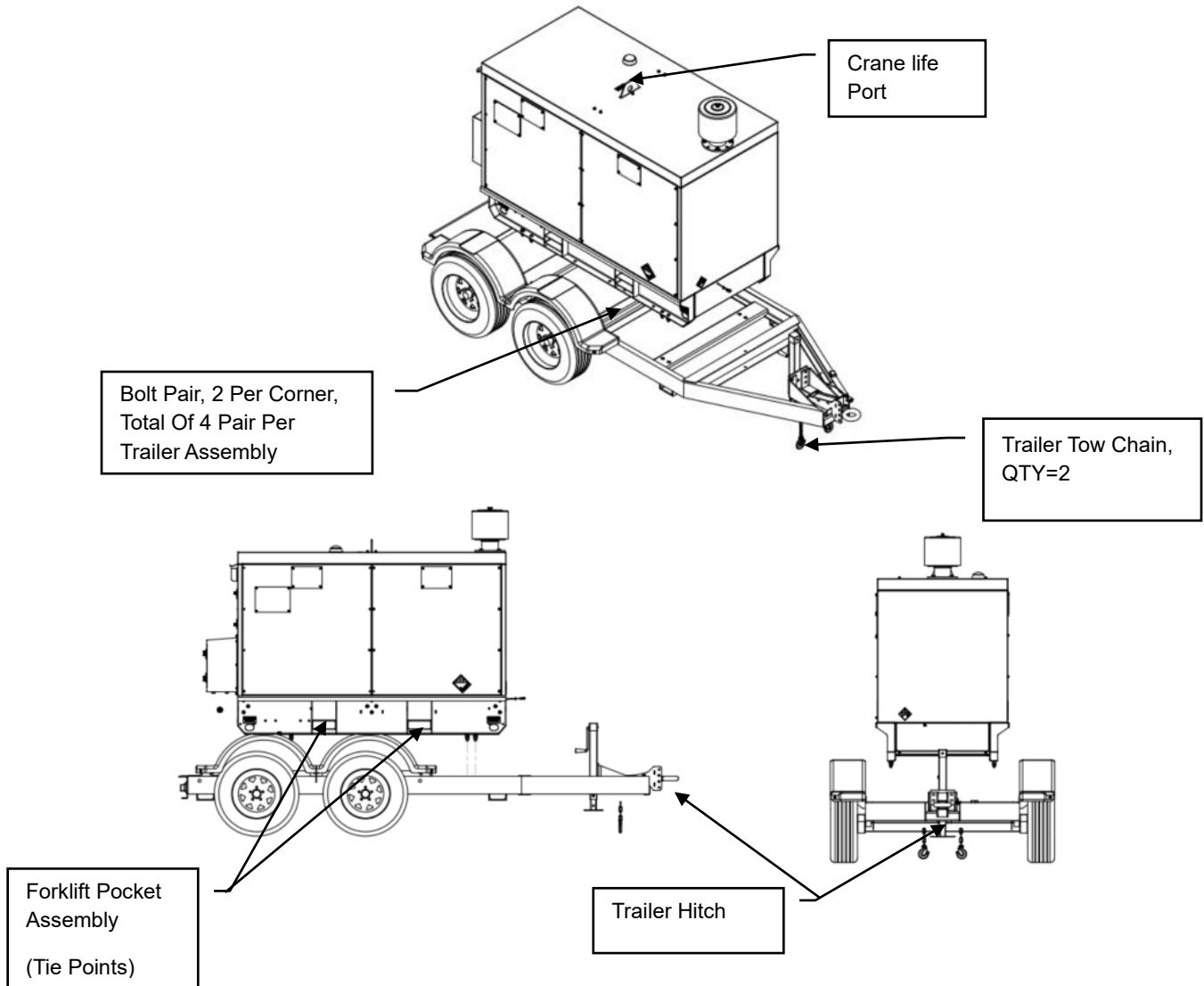

### 4.3.2 Transport Configuration

When securing a single or multiple SBR30 for transport, utilize the tie points on all four corners of the bottom skid of the SBR30. Do not use straps over the top, due to the risk of panel damage and/or cosmetic damage to the equipment. Proper loading and securing of the SBR30 elements and the devices used to secure the load is at the discretion and responsibility of the transportation driver and local highway regulations. Specific questions may be directed to Viridi Service at:

- 1-866-984-7434
- [service@viridiparente.com](mailto:service@viridiparente.com)

4.3.2.1 Transport Configuration Pictorial Representation (typical)

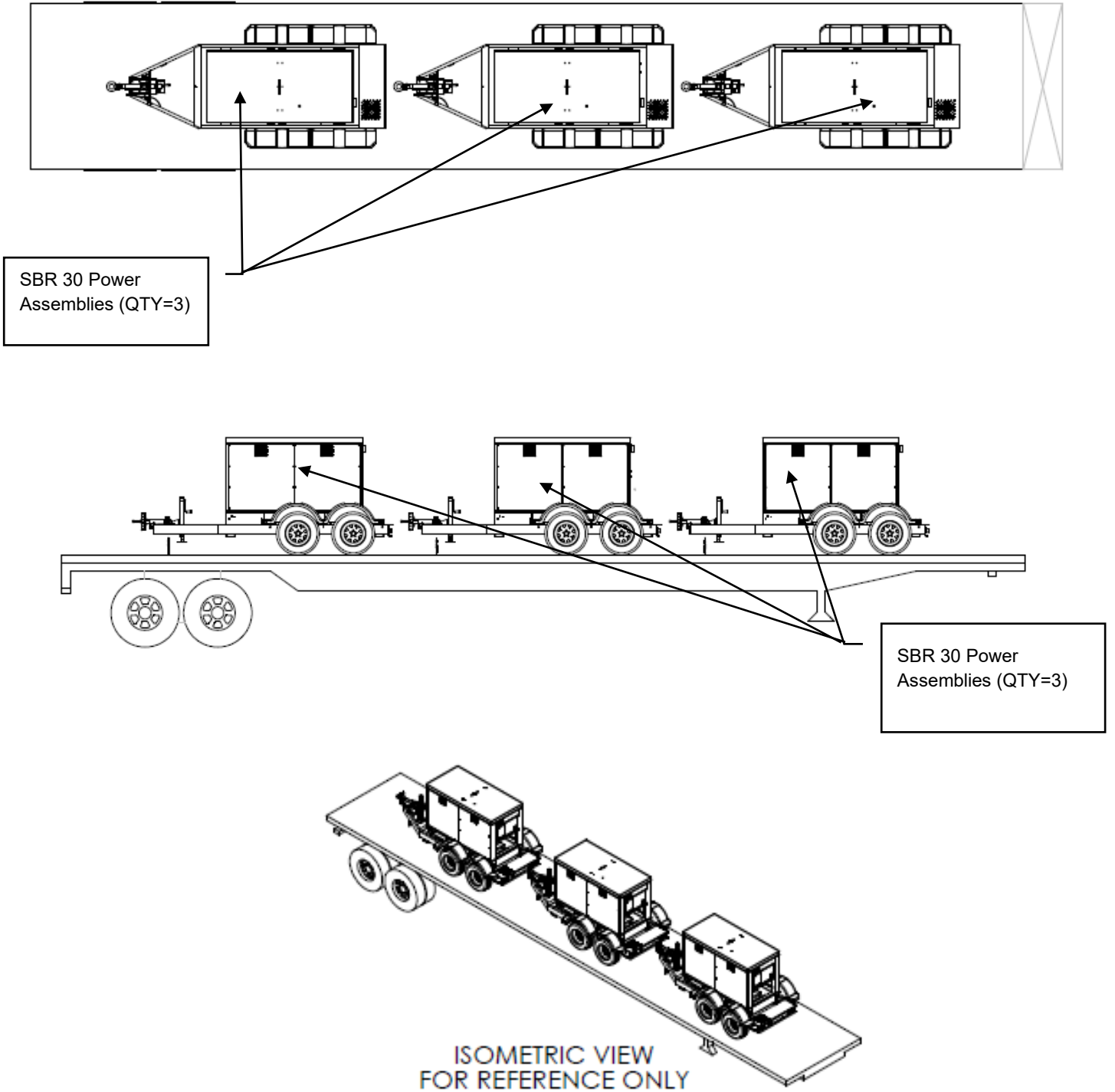

## 5. Operation: Overview

This section summarizes the SBR30 interfaces, categorized as *Displays*, *Connections*, *Controls*, and *User Interface*.

- **Displays** are the elements of the SBR30 that display information to the user.
- **Connections** are elements of the SBR30 used to connect other hardware to the BESS.
- **Controls** are the elements which the user operates to change the SBR30 settings.
- **User Interface** refers to the touchscreen for operator input controlling the SBR30's operating modes and configuration settings.

### 5.1 Displays

- User Interface touchscreen
- DEIF Controller Displays (LOAD/GRID & AUX/GEN)
- System Live Indicator ("ON" light)



## 5.2 Connections

### INPUTS

- Programming Ports
- DEIF CANBUS Ports
- AUX GENERATOR CONTACT G-240 AC/DC
- 24V battery trickle charge port
- Ground connection
- LOAD/GRID 400A CAM-LOCKS
- AUX GENERATOR 400A CAM-LOCKS

The primary connection interfaces to attach the SBR30 to external loads and power sources are the CAMLOCKS located on the lower right side of the rear control panel of the SBR30.

The LOAD/GRID CAMLOCKS on the left power an external load in discharge modes (along with Grid support in *ON-Grid Discharging*) or accept Grid input in charging modes. The AUX GENERATOR CAMLOCKS on the right will accept power from a generator or Grid connection to charge the SBR30 and/or provide power to an external load in generator hybrid mode.

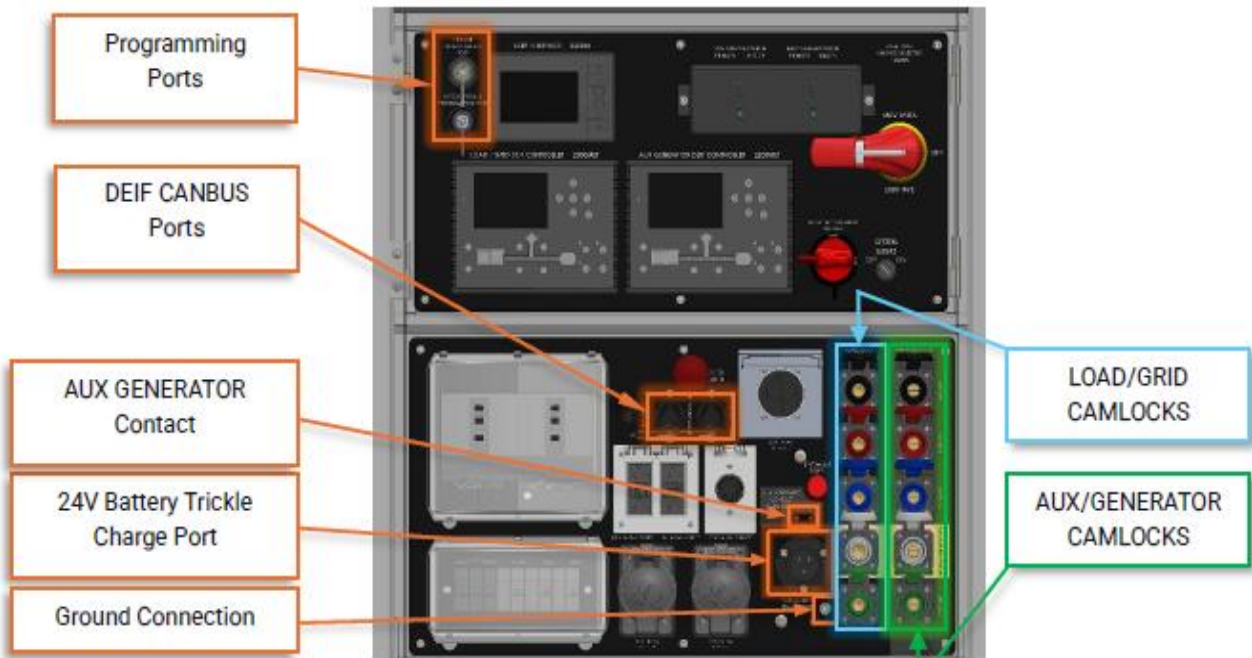

CAMLOCKS are aligned with their plugs by a keyed tab on the plug. To connect the CAMLOCKS, make sure the tab on the plug faces up. Insert the plug and turn clockwise to lock. Work your way from the top to the bottom for ease of connection. As a safety measure, the lefthand and righthand LOAD/GRID CAMLOCKS use different receptacles to prevent user connection errors.

Note: Color coordination for CAMLOCK AC Phase connections may differ in other countries. This manual follows the National Electric Code (NEC) standards.

### POWER OUTLETS

- 208V 1  $\phi$  50A (1731 Receptacle {RECT})
- 120V 1  $\phi$  20A (1701 Receptacle {RECT})
- 120V 1  $\phi$  20A (1705 Receptacle {RECT})
- 120V 1  $\phi$  30A (1709 Receptacle {RECT})
- 208V 1  $\phi$  50A (1721 Receptacle {RECT})
- 208V 1  $\phi$  50A (1725 Receptacle {RECT})

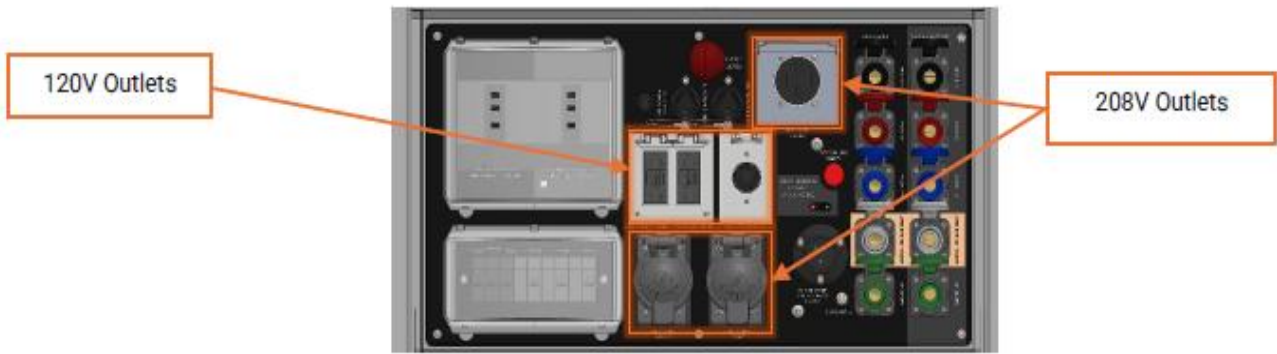

Three 120V outlets and three 208V outlets are provided for connecting to loads.

### 5.3 Controls

#### SWITCHES

- 208/480V Transfer Switch (16040TS)
- System Key switch (3605KS)
- 24V Battery Disconnect Switch (2521DISC)
- Emergency Stop (E-Stop) Button

#### CIRCUIT BREAKERS

- 208V / 480V Voltage Selector Switch Breakers (16110CB) / (16040CB)
- LOAD/GRID CAMLOCK Breaker (16111CB)
- AUX GENERATOR CAMLOCK Breaker (16041CB)
- 17xxCB (6 AC Circuit Breakers for protection for Convenience outlets / receptacles)
- DEIF CANBUS TERMINATOR

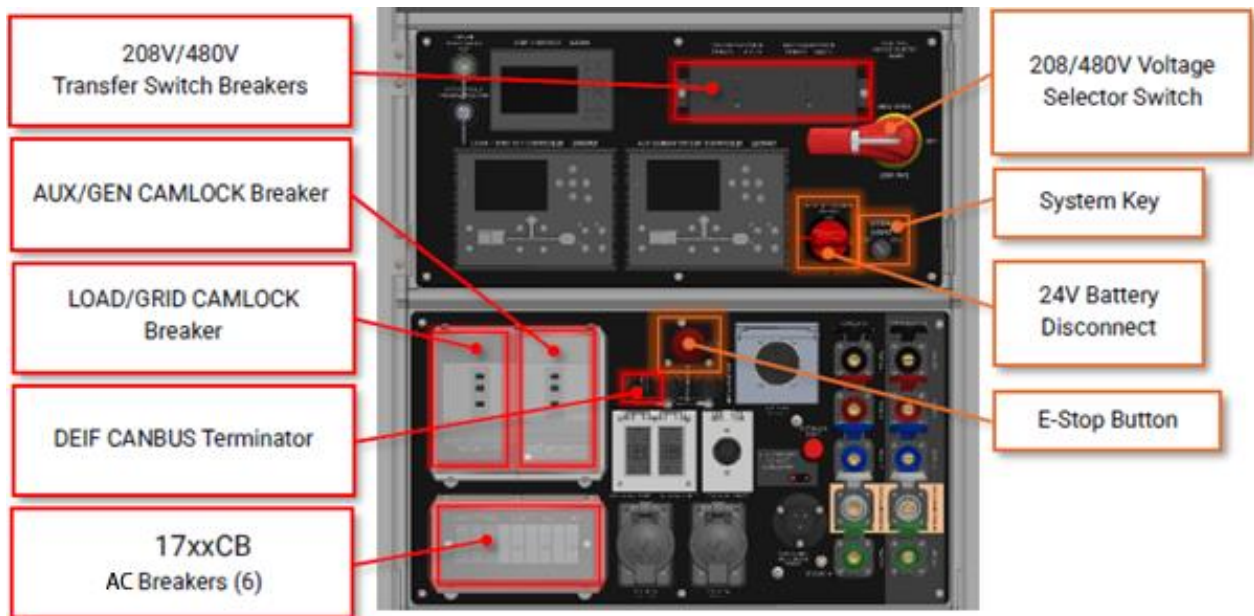

## 5.4 User Interface

The **Mode Selection** screen allows the user to set the operating mode of the SBR30 and access the other main screens.

The current mode is indicated by the green button.

Below the mode selection buttons are buttons to navigate to the Overview, Status, and Setpoints screens.

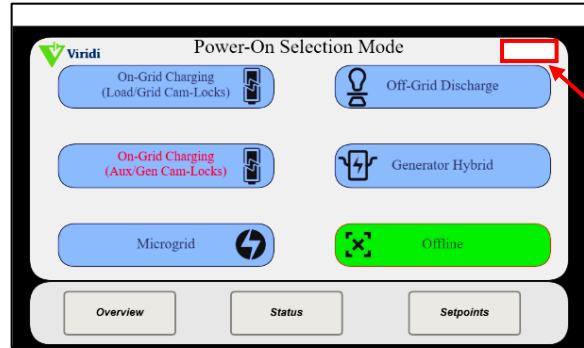

Current Software Version

The **Overview** screen shows a map of the power flow within the SBR30, the state of charge, the main transfer switch position, the state of connectors controlling power flow, and meter readings of the main components (Inverter, Line/Load in/out, and generator input).

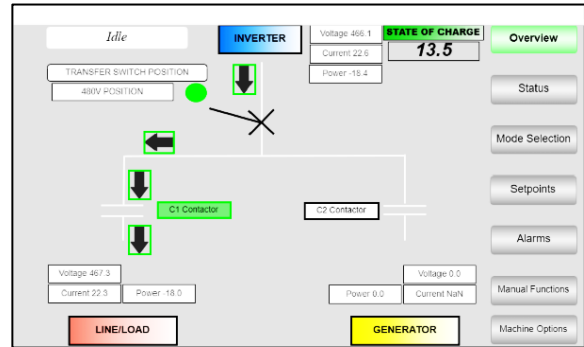

The **Status** screen gives a larger view of the component meter readings and voltage of the 24V battery supplying power to the SBR30. Tap a section to see the extended status screen for that section.

To Display extended information, press the box of the device. Available for LOAD/GRID, Inverter, Generator, BMS & Temperatures		
Load/Grid	Inverter	Generator
Voltage 0.0	Voltage 0.6	Voltage 0.0
Current NaN	Current 0.1	Current 0.0
Frequency 0.0	Frequency 0.0	Frequency 0.0
24V Battery	BMS	Software Version
Batt V. 26.5	SOC 25.0	V2.2.0.0
Temperatures		
Cabin 23 C		

The **Setpoints** screen allows user input controlling the performance of the SBR30. Clicking any of the colored buttons opens the settings for that mode.

All screens have a banner at the top to display the current alarm status, if any. To view system alarms, click the **Alarms** button.

Minimum SoC 20.0	Maximum SoC 90.0	Generator Hybrid Program Settings
Max Charge Current 65.0 A	Max Discharge Current 75.0 A	On-Grid Charging Program Settings
Active Power 15.0 kW	Reactive Power 0.0 kVAR	Microgrid Program Settings
Generator Warmup Time 30.0 s	Minimum Generator Run Time 5.0 m	Load limit before Gen Assist 20.0 kW
Current Limit before Gen Assist: --- A		

All screens *except* Mode Selection have navigation buttons on the right side to switch between screens.



The **Generator Settings** screen lets the user set parameters for remote generator connections. It includes an indicator light when the load is pulling higher power / current than the defined setpoint, and a generator / battery run time ‘odometer.’

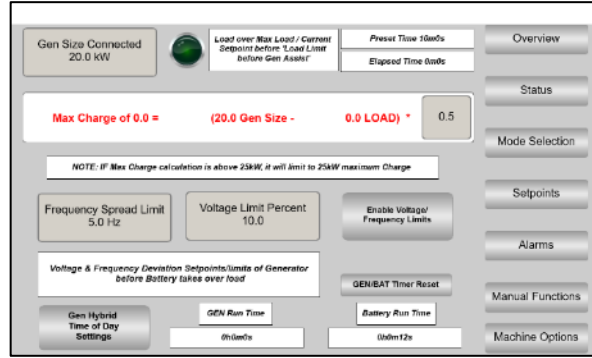

The **Machine Options** screen lets the user set various advanced machine settings (login required).

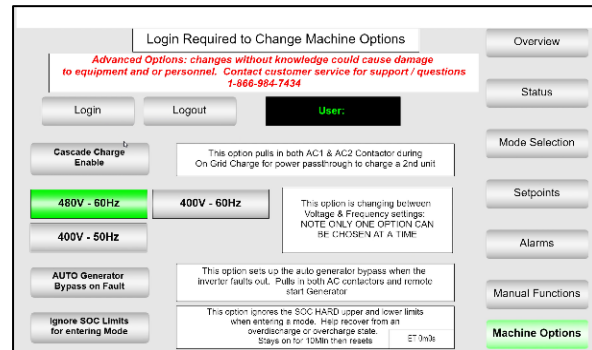

The **ON\_GRID Charge Program Settings** screen lets the user set parameters to automate the unit’s charge/discharge cycles based on State of Charge or Time of Day.

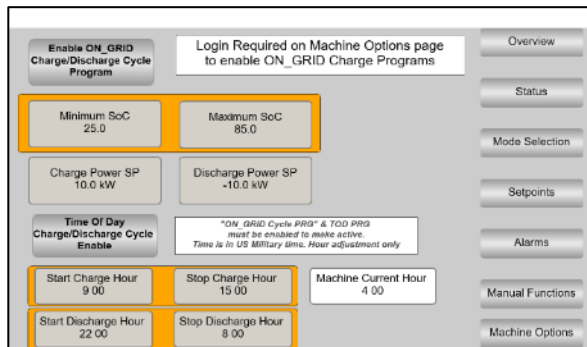

The **Manual Functions** screen provides manual control of the SBR30 two contactors and generator remote start. When in the Generator Hybrid Mode, the Manual Force Generator Sync button starts the Generator Sync process.

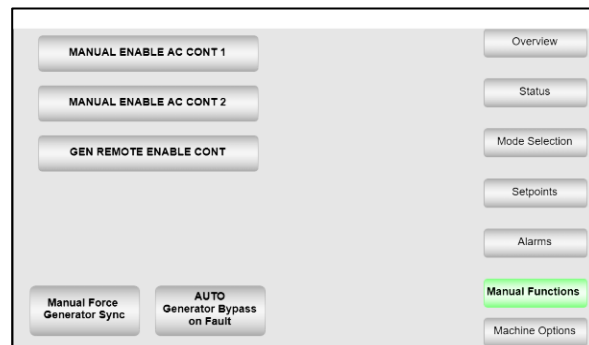

## 6. Operation: Information / Settings Screens

Informational displays and secondary settings are provided on these screens:

- Overview
- Status
  - Extended Status
- Setpoints
  - Generator Settings
  - ON\_GRID Charge Programs
- Alarms
- Manual Functions
- Machine Options

Descriptions of each screen are on the pages which follow.

### 6.1 Overview

The Overview screen provides a graphical representation of power flow within the unit, as well as the Operating Mode, State of Charge, Transfer Switch State (208V / 480V / Off) and the State of Contactors directing power flow to/from Camlocks. Real-time meter readings are provided for the Inverter, LINE/LOAD Camlocks, and Generator Camlocks.

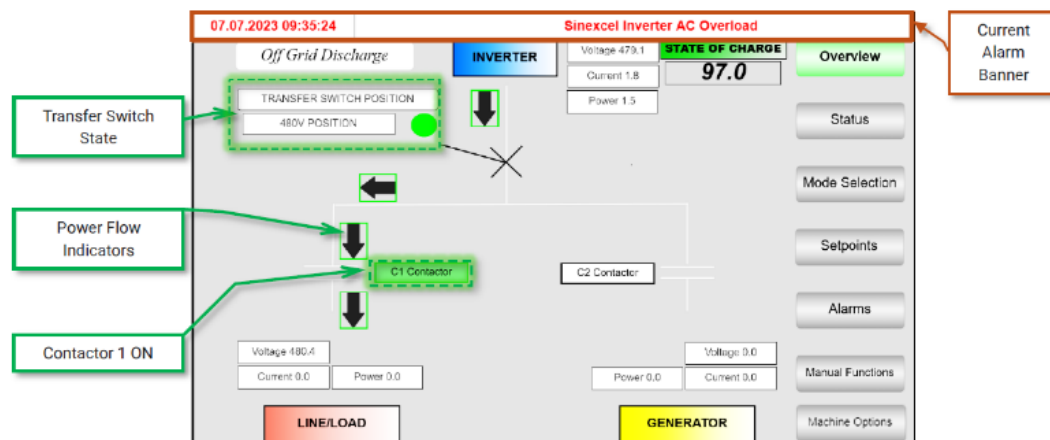
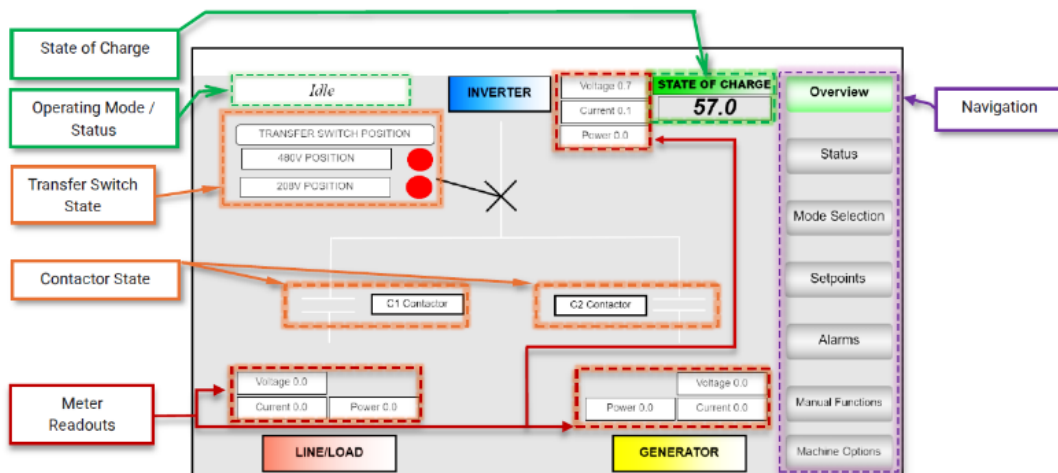

## 6.2 Status

The Status screen provides a larger display of the SBR30 real-time meter readings. Voltage, Current, and Frequency are shown for the ASC150 Storage, Inverter, and DEIF ASC150 BTB (marked Generator). At the bottom of the display, the lead acid 24V battery voltage, the BMS (Battery Management System) State of Charge, the Software version, and the Temperatures are shown.

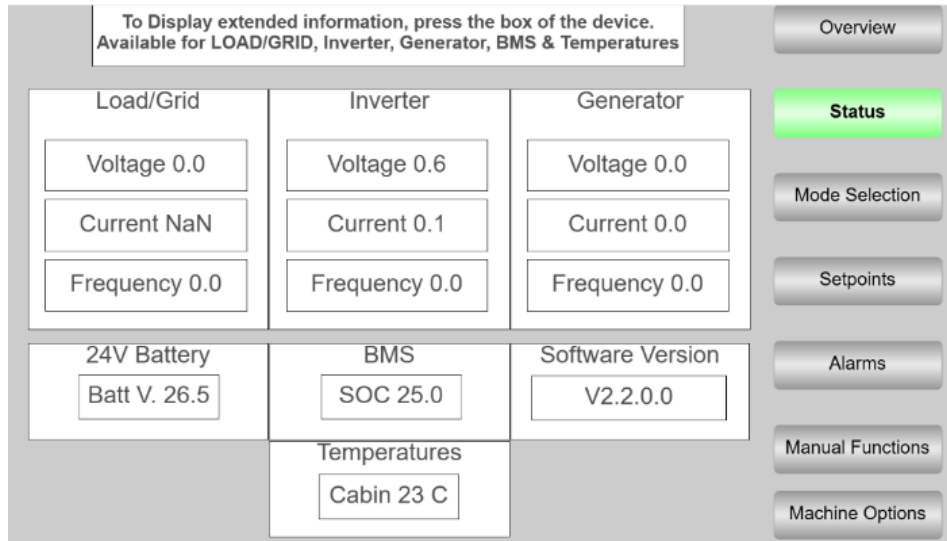

## 6.3 Extended Status Screens

Tapping any area of the Load/Grid, Inverter, Generator, or BMS sections opens the Extended Status pop-up display for the selected component(s). The pop-up shows more details about the status of the selected component(s).

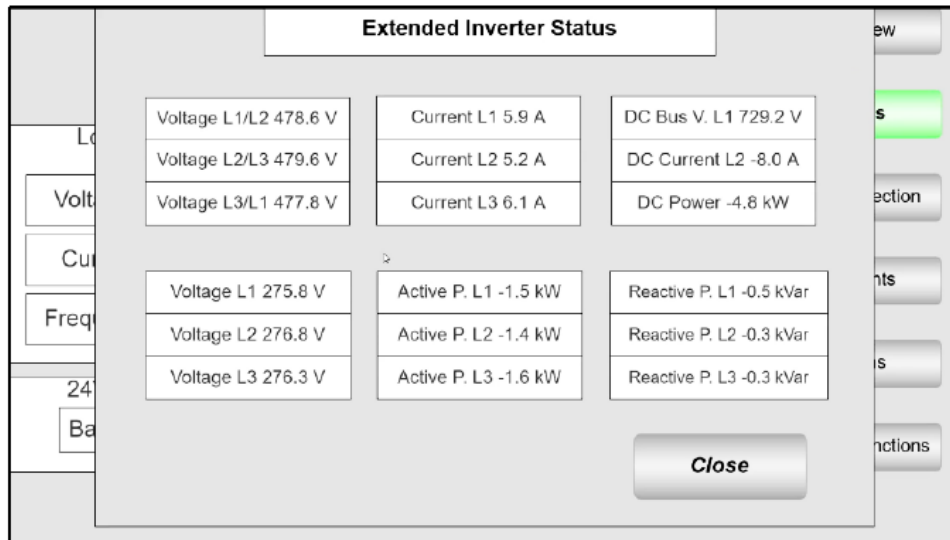

## 6.4 Setpoints

The setpoints screen allows the user to set the SBR30 up for specific system applications. Each setpoint is indicated by a grey button.

- A yellow **Generator Hybrid Programs Settings** button opens the Generator Settings window to specify generator parameters.
- A red **ON-GRID Charging Program Settings** button opens the On-Grid Charge Programs window to automate charge/discharge programs.
- A green **Microgrid Program Settings** button opens the Microgrid settings window to adjust a variety of microgrid settings.

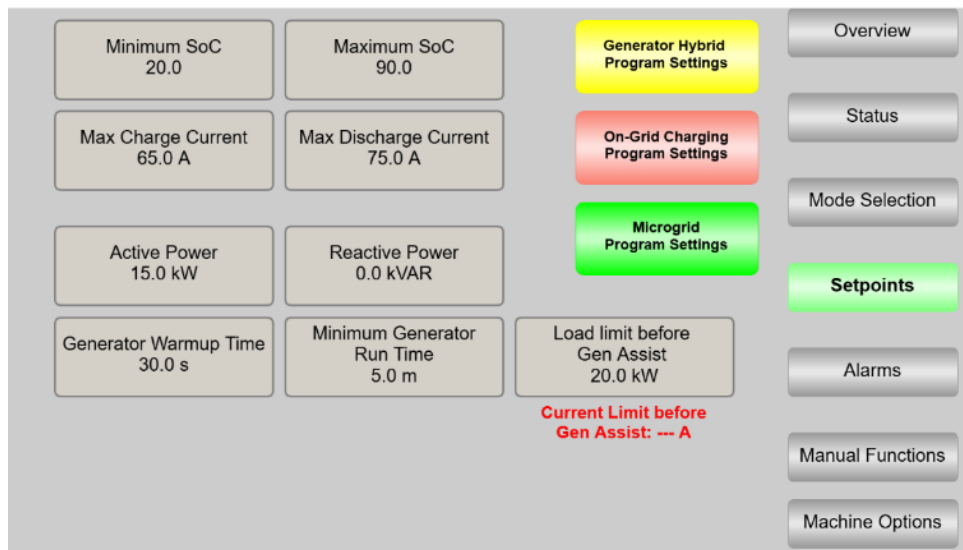

Setpoints summary:

- **Minimum State of Charge / Maximum State of Change (%)**: State of charge limits to start/stop charging from a generator in *Generator Hybrid* mode.
- **Max Charge Current (A) / Max Discharge Current (A)**: Battery charge current limits in *On-Grid Charging* mode.
- **Active Power (KW)**: Sets the amount of power the inverter can receive to charge. Automatically set in *Gen Hybrid* or *Microgrid* mode.
- **Reactive Power (kVAR)**: Sets the amount of reactive power the inverter can receive to charge. The inverter WILL charge at those settings unless overridden by other maximum limits. This is automatically set in *Gen Hybrid* or *Microgrid* mode.
- **Generator Warmup Time (seconds)**: sets a delay on remote generator startup. Used when the generator is set up at a distance from the SBR30.
- **Minimum Generator Run Time (minutes)**: To prevent cycling, set the minimum time for the generator to run even if generator input is no longer needed (1-10 minutes).
- **Load Limit before Generator Assist (kW)**: Set the Power limit above which the generator will turn on in Generator Hybrid mode. The red text below the button monitors the current limit before calling for a generator assist.

## 6.5 Generator Settings

The Generator Settings screen includes these inputs and displays for configuring connected generators:

**User Inputs:** tap the button to set generator parameters:

- **Gen Size Connected (KW):** sets the generator size in KW.
- **Frequency Spread Limit (Hz):** The lower limit below which the unit switches back to battery power.
- **Voltage Limit Percent:** The Voltage percent below which the unit switches back to battery power.
- **GEN/BAT Timer Reset:** Tapping the button resets the Battery Run Time and GEN Run Time displays.
- **Gen Hybrid Time of Day Settings:** Opens a window to allow for setting of times when the generator is allowed to run. (See paragraph 6.5.2 – Generator Hybrid Time of Day Settings)

### 6.5.1 Displays

- **Load over Max (indicator light):** when the Load or Current limit set on the *Setpoints* screen is exceeded, the indicator light turns on.
- Generator Assist Run Time Displays:
  - **Preset Time (display):** Shows preset generator run time in minutes and seconds.
  - **Elapsed Time (display):** Shows elapsed time Load has been below the limit before switching back to Battery Power.
- **Max Charge Calculation (display, red text):** Displays how much the unit can charge based on generator size setting and the Load.
- **Battery/Gen Run Time (display):** Shows a cumulative timer indicating how long the Battery and Generator have been running. To reset both, tap the **GEN/BAT Timer Reset** button.

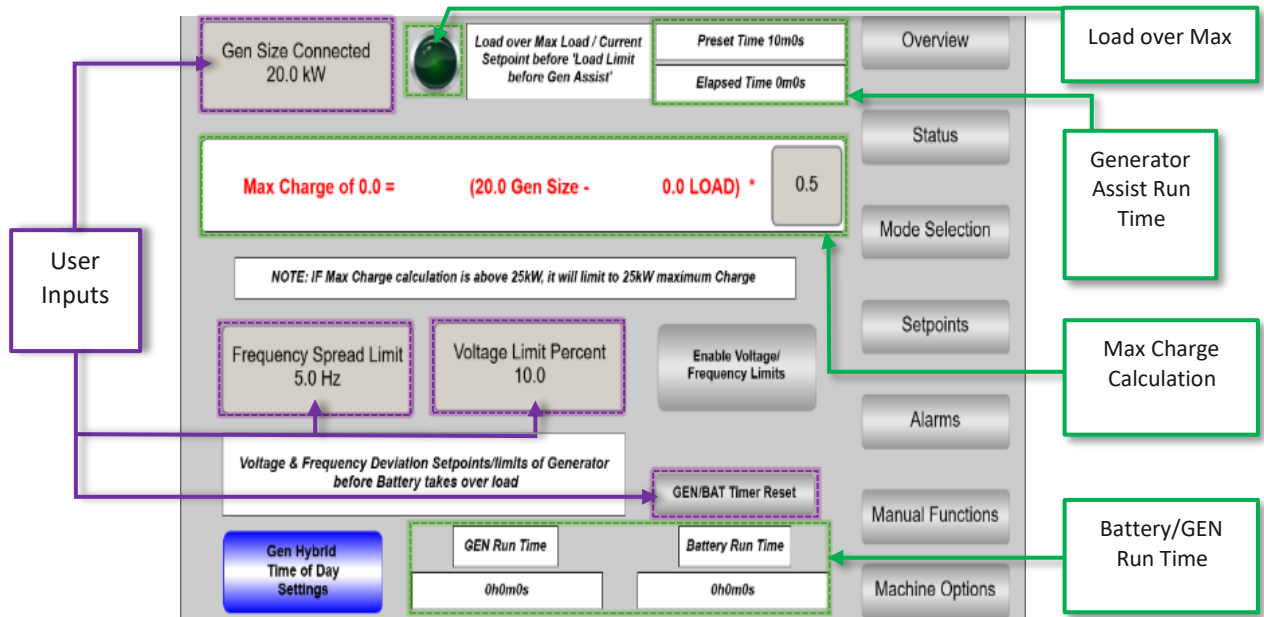

## 6.5.2 Generator Hybrid Time of Day Settings

- **Start Generator Hour:** Sets the hour from which the generator will be allowed to run.
- **Stop Generator Hour:** Sets the hour from which the generator will not be allowed to run

Login Required on Machine Options page to enable Generator Hybrid Time of Day

*"Generator Hybrid Time of Day Enable" must be enabled to make active. At Start Hour, Generator will be turned on and BESS will sync. At Stop Hour, will turn off the request, switch back to BESS only if the following conditions are met:*  
- Load below "Load limit before Gen Assist"  
- Battery SOC at or above the Maximum SOC setpoint  
Time is in US Military time. Hour adjustment only

Generator Hybrid Time Of Day Enable

Start Generator Hour 22 00

Stop Generator Hour 8 00

Machine Current Hour 4 00

Gen Battery Charge Settings / calculations

Overview

Status

Mode Selection

Setpoints

Alarms

Manual Functions

Machine Options

Start and Stop Generator Hour Buttons

## 6.6 ON\_GRID Charge Programs

This screen provides access to automated charge/discharge programs based on State of Charge/Power or Time of Day. *Accessing these options requires user login on the Machine Options page.*

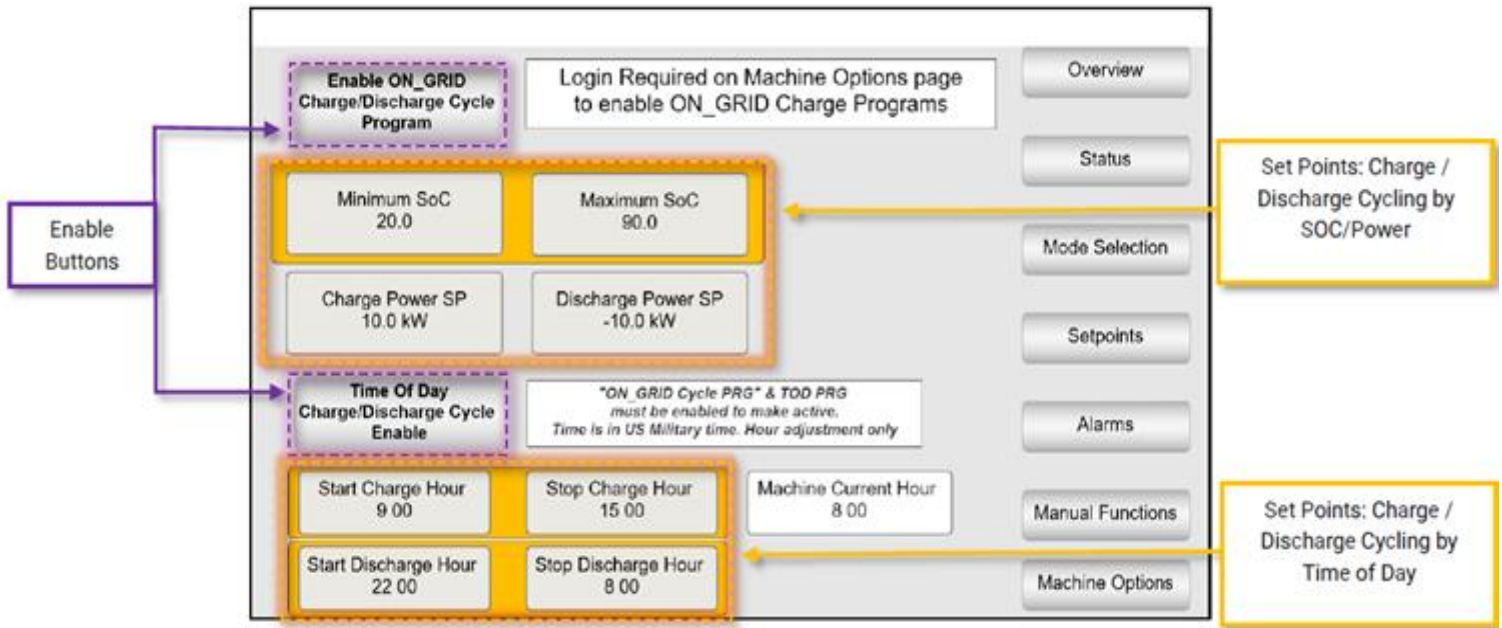

After logging in on the *Machine Options* page, tap on setpoints to define:

- STATE OF CHARGE (SoC) / POWER SETPOINTS (SP):
  - **Minimum SoC:** Begin charging when the unit is at the setpoint.
  - **Maximum SoC:** Begin discharging when the unit is at the setpoint.
  - **Charge Power SP:** Charge at the specified power.
  - **Discharge Power SP:** Discharge at the specified power.
- **TIME OF DAY SETPOINTS** (using a 24-hour clock):
  - **Start Charge Hour:** Start charging at the specified time.
  - **Stop Charge Hour:** Stop charging at the specified time.
  - **Start Discharge Hour:** Start discharging at the specified time.
  - **Stop Discharge Hour:** Stop discharging at the specified time.

To enable a Charge / Discharge Cycle Program, click the corresponding Enable Button. Enabling the SOC/Power Program will start the unit Charging / Discharging at the SOC/Power Setpoints. Enabling the Time-of-Day Program requires the SOC/Power Program to be enabled. The unit will Charge / Discharge at the SOC/Power Setpoints when the time is between the Time-of-Day setpoints.

## 6.7 Alarms

The Alarms screen displays the SBR30's event log. The main screen shows any active alarm present. When the SBR30 boots, this screen will be blank.



The screenshot shows the Alarms screen with a populated event log table. The table has columns for 'Timestamp' and 'Message'. The 'Alarms' button is highlighted in green. The 'Alarm History Toggle On/Off' button is highlighted in blue.

	Timestamp	Message
0	15.05.2025 03:43:59	ESTOP PRESSED!! Reset ESTOP and Cycle power to machine
1	15.05.2025 03:43:54	Unit put into OFFLINE MODE
2	15.05.2025 03:37:23	ESTOP PRESSED!! Reset ESTOP and Cycle power to machine
3	08.05.2025 04:08:36	ESTOP PRESSED!! Reset ESTOP and Cycle power to machine
4	05.05.2025 03:32:18	ESTOP PRESSED!! Reset ESTOP and Cycle power to machine
5	01.05.2025 03:21:07	Unit put into OFF GRID DISCHARGE MODE
6	01.05.2025 03:21:06	Unit put into OFF GRID DISCHARGE MODE
7	01.05.2025 03:21:06	OffGrid: Transfer Switch Position 480V Ack
8	01.05.2025 03:20:11	OffGrid: Transfer Switch Position 480V Ack
9	01.05.2025 03:17:15	ESTOP PRESSED!! Reset ESTOP and Cycle power to machine
10	30.04.2025 03:20:26	ESTOP PRESSED!! Reset ESTOP and Cycle power to machine
11	29.04.2025 06:32:09	Hybrid: Generator Setup for 480V Ack
12	29.04.2025 06:32:09	Unit put into GENERATOR HYBRID MODE
13	29.04.2025 06:32:04	Hybrid: Load Setup for 480V Ack

The Alarm History Screen has two buttons at the bottom right of the screen to provide additional functions:

- **Alarm History Toggle On/Off:** Show/Hide the Alarm History as a scrollable list of alarms.
- **Alarm Reset:** Tap to reset active alarms.

## 6.8 Manual Functions

This screen provides manual controls for enabling/disabling the 208/480V contactors and the generator remote start.

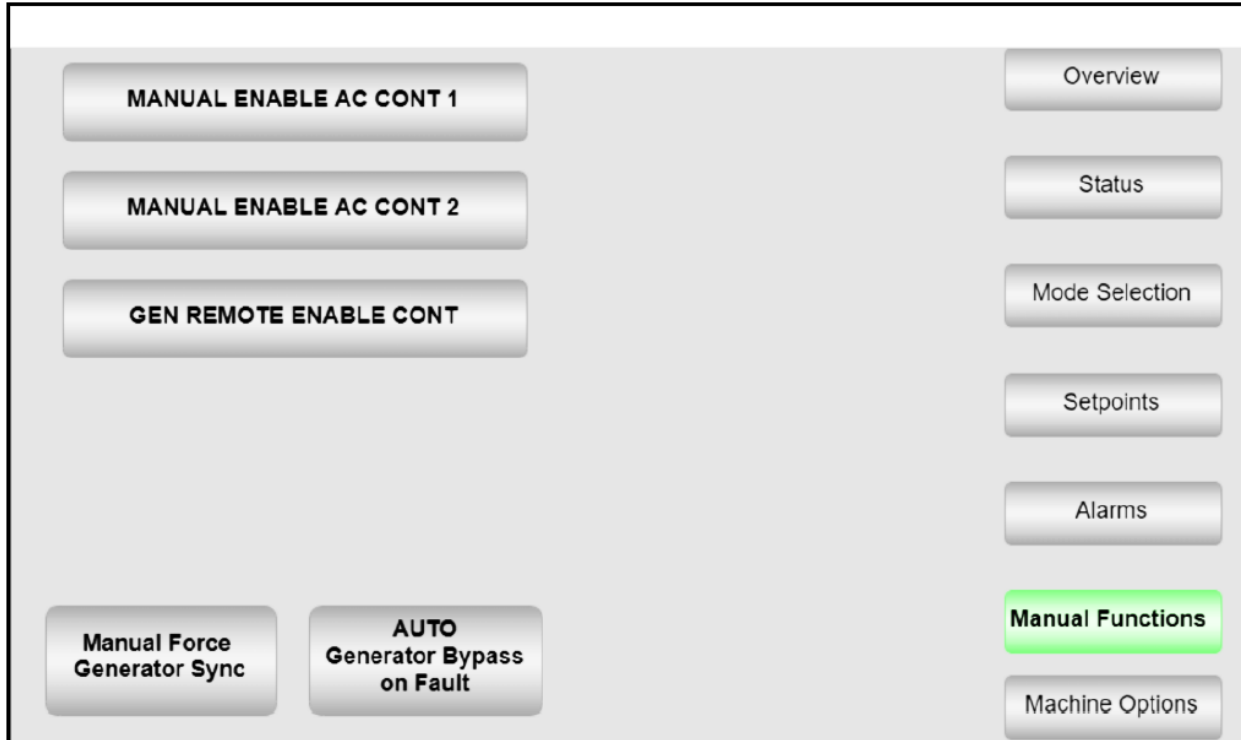

When contactor 1 is enabled, power flows through the LOAD/GRID CAMLOCKS. When contactor 2 is enabled, power flows through the AUX GENERATOR camlocks. To manually enable contactor 1, tap the **MANUAL ENABLE AC CONTACT 1** button. To manually enable contactor 2, tap the **MANUAL ENABLE AC CONTACT 2** button.

When a generator is connected by cable to the **AUX GENERATOR CONTACT**:

- Tap the **GEN REMOTE ENABLE CONTACT** button to send a remote call for the generator to start.
- Tap the **Manual Force Generator Sync** button to call the generator to start and synchronize when the unit is in *Generator Hybrid Mode*. In other modes, the button is non-functional.
- Tap the **AUTO Generator Bypass on Fault** button to automatically call the generator to supply the load if there is a machine fault that would otherwise put the unit offline. This button acts as a toggle.

## 6.9 Machine Options

This screen lets users configure the following advanced options. Tap the User Input Buttons as needed to perform the actions described below.

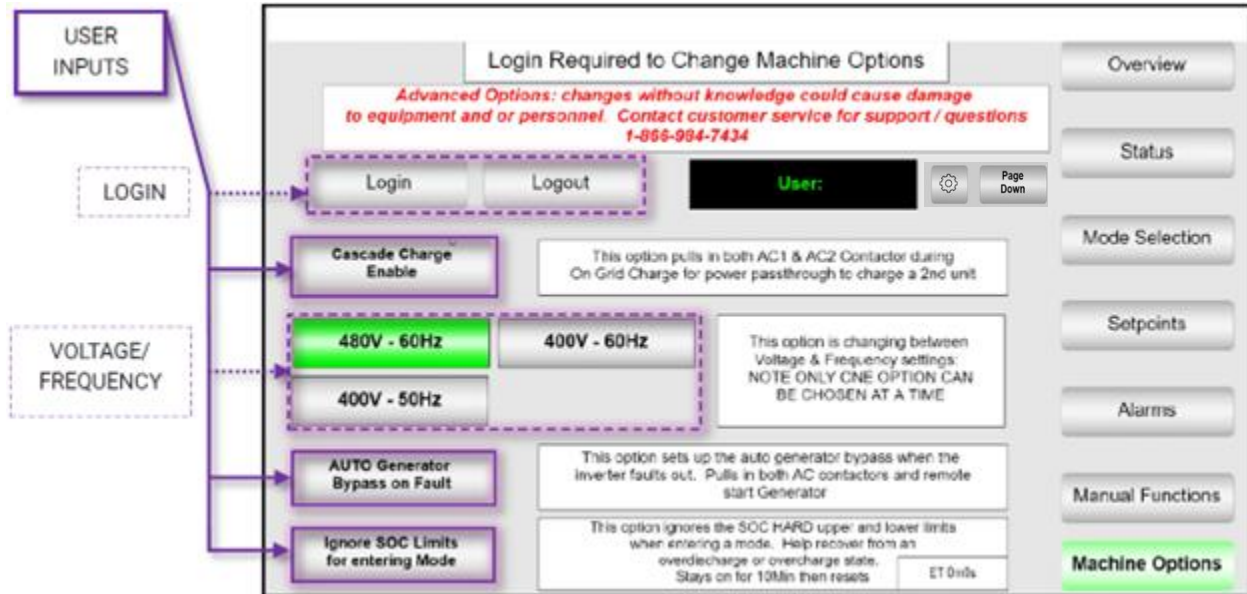

### 6.9.1 USER INPUTS

- **LOGIN:** (required before tapping any other Machine Option Button)
  - **Login:** Tap to enter the admin pin number (provided when unit was purchased). Upon login, the *User:* display shows *User: Administrator*.
  - **Logout:** Tap to perform an admin logout.
- **Cascade Charge Enable:** Tap to pull in both AC1 & AC2 Contactors when in *On-Grid Charging* mode for power passthrough to charge another unit.
- **VOLTAGE/FREQUENCY:**
  - **480V / 60 Hz:** Tap to set voltage of 480V and Frequency of 60Hz.
  - **400V / 60 Hz:** Tap to set voltage of 400V and Frequency of 60Hz.
  - **400V / 50 Hz:** Tap to set voltage of 400V and Frequency of 50Hz.
- **AUTO Generator Bypass on Fault:** Tap to pull in both AC1 & AC2 Contactors and remote start the Generator. This sets up the AUTO Generator Bypass when the inverter goes into a fault condition (see also *Manual Functions* Screen).
- **Ignore SoC Limits for entering Mode:** Tap to set the unit to ignore Minimum/Maximum SoC limits when entering a mode of operation. This helps recover from an overcharge or over-discharge state. This function remains active for 10 minutes when activated, then resets.
- **Page Down:** Tap to view additional controls such as Auto-restart and Fan control.

Login Required to Change Machine Options

**Advanced Options: changes without knowledge could cause damage to equipment and or personnel. Contact customer service for support / questions 1-866-984-7434**

Login Logout **User:** Page Up Page Down

**Auto Restart on Microgrid Inverter Fault**

Gen Assist Delay Timer 3.0 s

Load Below Max Delay 10.0 m

Decrease Voltage -

Load Voltage 0.0

This option will bring the RPS150 back into Microgrid mode after the Inverter overloads and the inverter fault clears

GENERATOR HYBRID OPTION: This option adjusts the delay timer setting before Generator turns on to assist when the load is above the setpoint limit. ET 0s

GENERATOR HYBRID OPTION: This option adjusts the wait timer setting before switching back to Battery once the load is below the Gen assist load limit

Reset

Inverter Voltage 0.6

This option will increase / decrease the load voltage incremently by 2 volts.

Login Required to Change Machine Options

**Advanced Options: changes without knowledge could cause damage to equipment and or personnel. Contact customer service for support / questions 1-866-984-7434**

Login Logout **User:** Page Up Page Down

**Reboot High Voltage Circuit**

**AUTO**

This option reboots the RPS150 High Voltage Circuit - Turns off the Li-Ion Batteries, Turns off the Pre-charge circuit. After 5 seconds restarts the sequence

Fan Control: Select if the unit cooling fans are Always On, Always Off or Auto

## 7. ViSTA

The SBR30 utilizes a wireless cellular communications module to send location and usage metrics to an administrative dashboard called ViSTA. The following will provide the basics for utilizing ViSTA.

### 7.1 Logging In

Requests can be submitted for BESS Alert Notifications and Basic Vista User Account through the Viridi Vista User Request Form.

Follow the link or QR Code below to submit the Viridi Vista User Request Form.

[Viridi Vista User Request Form](#)

<https://forms.office.com/r/mjH2FQr9DR?origin=lprLink>

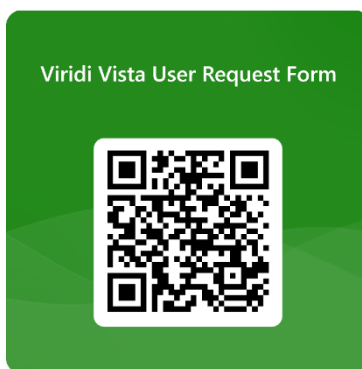

Find an email from ViSTA notifications with a link to create your ViSTA account. Must be completed promptly as expired activations will require a new request form. Setting up your account and login by going to <https://vista.viridiparente.com/login>. You will be requested to provide:

- Username (Email)
- Password

## 7.2 ViSTA Notifications

Follow the link or QR Code below to submit the Viridi Vista User Request Form. Requests can be submitted for BESS Alert Notifications and Basic Vista User Account.

Viridi Vista User Request Form → <https://forms.office.com/r/mjH2FQr9DR?origin=lpLink>



For additional assistance, questions, or custom requests, please contact Viridi Service at:

- 1-866-984-7434
- service@viridiparente.com.

## 7.3 ViSTA Dashboard

Upon logging in you will see the ViSTA dashboard. This will allow you to see and track a variety of data about any of your SBR30 over a given time period. This includes the battery metrics and total pack cycles, the inverters' performance, how the load/grid is functioning with the SBR30, and how the Aux/Generator is performing if an Aux/Generator is in use.

Equipment ID	Serial	Type	Status	Location Group	Parallel Group
VPS30B-0401240159-BF	0401240159-BF	SBR30	Offline		
VPS30B-0508240383-BF	0508240383-BF	SBR30	Offline		
VPS30-0111220006	0111220006	SBR30	Online	Microsoft D	
VPS30-0111220005	0111220005	SBR30	Offline		
VPS30-0111220007	0111220007	SBR30	Offline		
VPS30-0111220011	0111220011	SBR30	Offline		
VPS30B-0313240219	0313240219	SBR30	Offline		
VPS30B-0104230030	0104230030	SBR30	Online	Area 26	
VPS30B-0104230029	0104230029	SBR30	Online	PCI1484 Cotton Kitchie	
VPS30B-0111220020	0111220020	SBR30	Online	PCI1484 SLSCO Laundry	
VPS30B-0111220014	0111220014	SBR30	Online		
VPS30B-0104230033	0104230033	SBR30	Online		
VPS30B-0111220015	0111220015	SBR30	Online		
VPS30B-0111220016	0111220016	SBR30	Offline		

Created time	Originator	Serial	Type	Severity	Status
2025-06-16 13:12:14	Vista Connection Lost to Asset	10765306	0209230110-EW	Warning	Cleared Unacknowledged
2025-06-16 12:58:05	Emergency Stop Pressed	10765240	VPS30B-0209230098	Major	Cleared Unacknowledged
2025-06-16 12:58:05	SOC Below 5 Percent	10765240	VPS30B-0209230098	Critical	Cleared Unacknowledged
2025-06-16 12:58:05	SOC Below 5 Percent	10765240	VPS30B-0209230098	Major	Cleared Unacknowledged

### 7.3.1 Device Identification and Overview

Under equipment ID and serial, you will be able to identify your SBR30.

To the right of your unit, you will be able to view the following from left to right:

1. Status, which will be either Offline or Online
2. Show location group and if it is part of a generator group
3. Notes, which you will have the option to look at or leave notes.
4. Check the AGC configuration history
5. Modify the location group
6. Modify the parallel group
7. Check the modem details
8. Look at the diagram - which has all the deeper metrics concerning the and BESS, the Load/Grid, and the Aux/Generator if in use.
9. Check any past alarms.

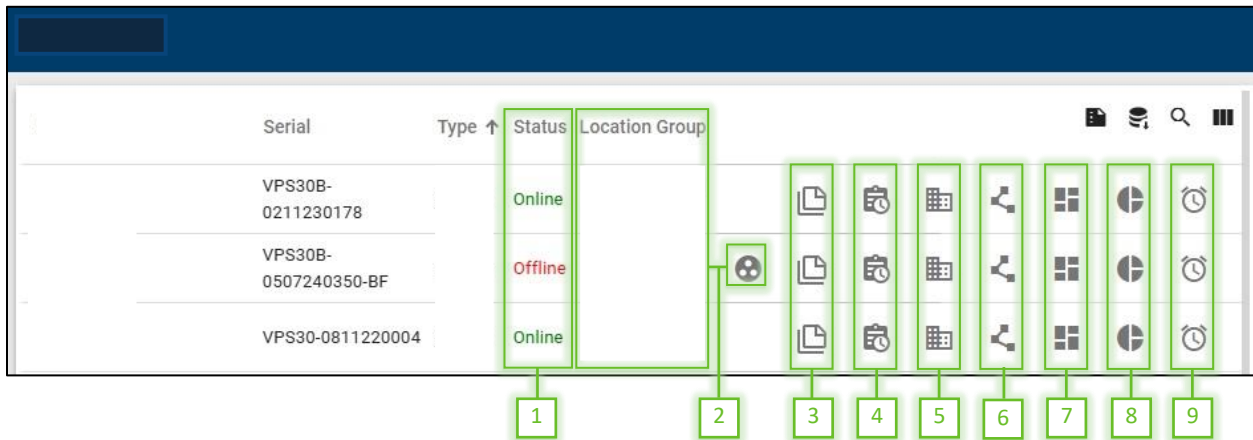

### 7.3.2 The Map

The map allows you to zoom in on your device's location using the mouse wheel or the + and – buttons on the map. Clicking on your device will pop up a screen with the serial number, location group, parallel group, latitude and longitude, when it was last seen by the system, CPU temp, and a diagram button

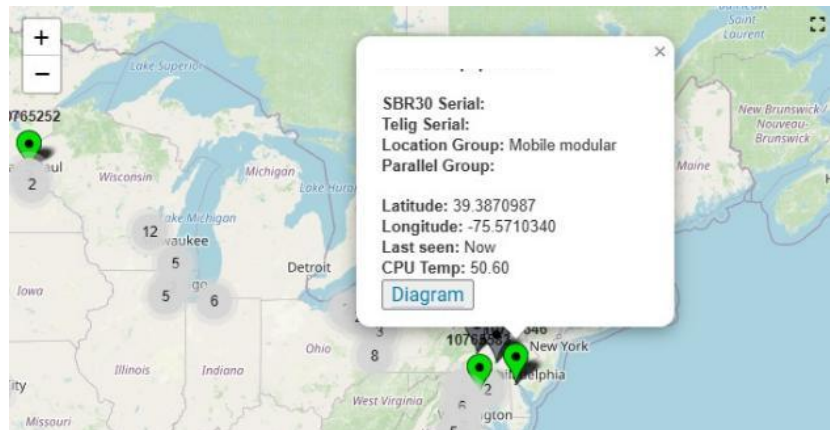

The color of the map pins has the following meanings:

- Green: "Online and no Alarms"
- Grey: "Not connected to ViSTA"
- Orange: "Online with Minor Alarm"
- Red: "Online with Major Alarm"



### 7.3.3 Alarms

The alarms area allows you to see what device has had an alarm, when the alarm occurred, the type of alarm, the severity, and the status of the alarm on the BESS.

🕒 Realtime - last day						
<input type="checkbox"/>	Created time ↓	Originator	Serial	Type	Severity	Status
<input type="checkbox"/>	2025-05-19 09:11:54			AC Overload Timeout	<b>Major</b>	Active Unacknowledged 
<input type="checkbox"/>	2025-05-19 09:02:35			AC Phase Lost	<b>Minor</b>	Cleared Unacknowledged 

Clicking on the box to the left of the alarm will allow you to acknowledge and/or clear the alarm on ViSTA but not on the SBR30 itself. The problem will persist until it is dealt with.

Clicking on the word bubble icon on the right will allow you to see the activity of the SBR30 and add comments concerning the alarm.

### 7.3.4 The Diagram

Clicking on any of the diagram links on the Dashboard will bring you to the diagram screen. The diagram screen has baseline information on four parts of the system.

- Battery
- Inverter
- Load/Grid
- Aux/Gen (if applicable)

Each of those areas is also a clickable button that will open another screen to provide more detailed information on how those parts of the system are functioning.

- On the right side of the diagram screen is additional information
- The online or offline status of the device
- The outside temperature
- The temperature inside the shell of the SBR30
- The battery temperature
- What the transfer switch is set to currently
- Savings on CO<sub>2</sub> and fuel. These are estimates.

Along the bottom lists the current mode and firmware version of the SBR30.

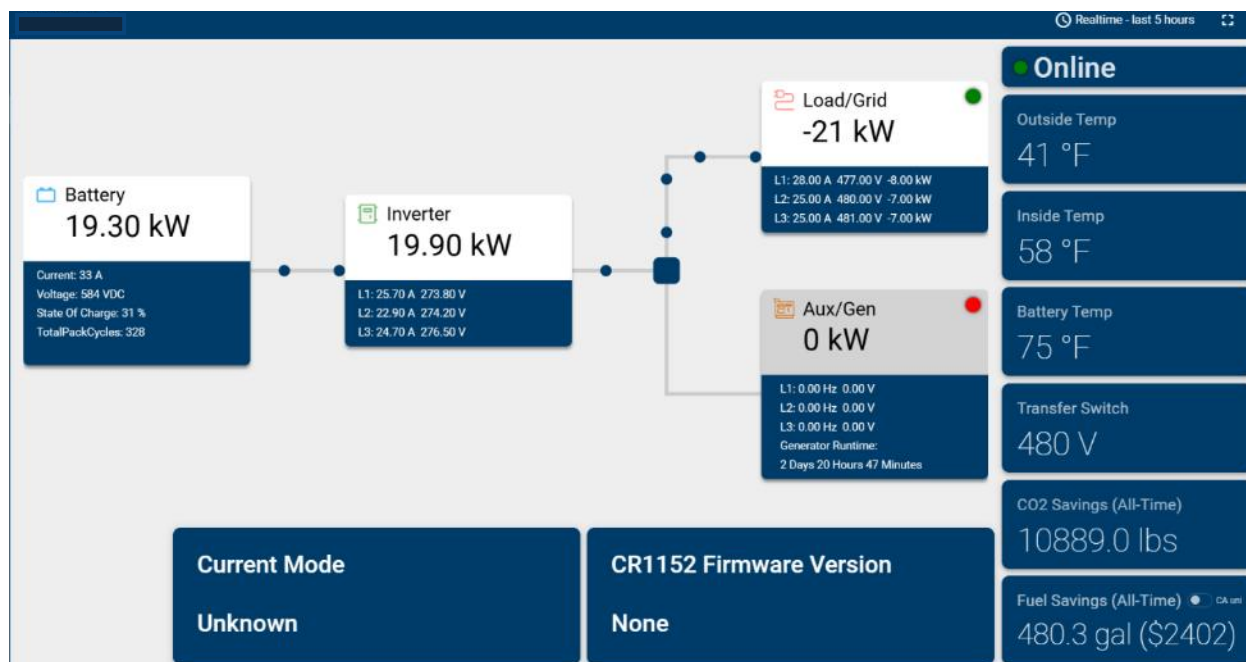

### 7.3.5 More Detailed Telematics

Clicking any of the four buttons, (Battery, Inverter, Load/Grid, or Aux/Gen) will bring up a variety of information about that part of the system.



### 7.3.6 Data Over Time

By clicking the clock icon in the upper right-hand corner of any of the diagram or system devices screens you will open a menu that will allow you to view the real time activity or history of the system.

The real time tab allows you to choose a period to view from the current time to however long ago you select.

The History tab is the same as the real-time tab except for the ability to choose a period of time in the past to view instead of just allowing you to view what the system is doing for an ongoing time frame. For example, you can view a day from three weeks ago instead of the past 24 hours.

Date specific ranges can be accessed by clicking the **Advanced** button.

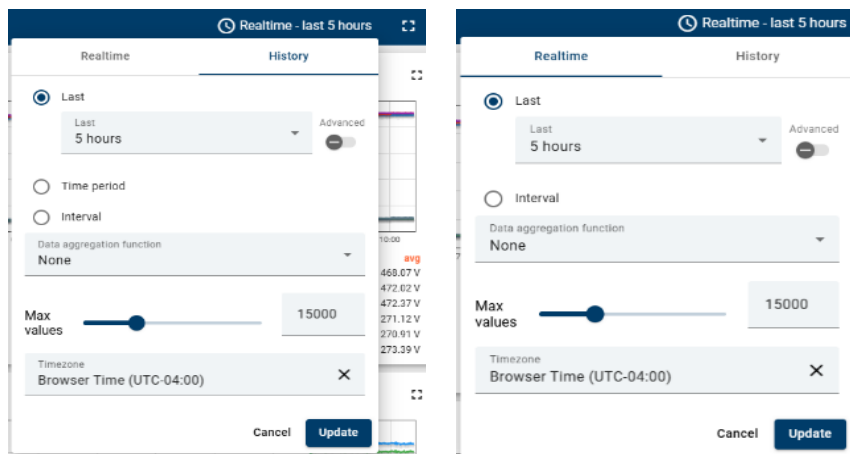

## 8. Operating Modes

*This section explains procedures for setting up the SBR30 in each mode:*

- **Powering ON**
- **On-Grid Charging Mode** using (Load/Grid Camlocks) or (Aux/Gen camlocks) – Connect to the Grid to recharge and provide Grid support.
- **Off-Grid Discharge Mode** – Powering the load without connecting to the grid.
- **Generator Hybrid Mode** – Powering the load with a Generator connected to support and charge as needed.
- **Microgrid Mode** – Interconnecting one or more SBR30 for increased power capability. Also referred to as ‘paralleling.’
- **Powering OFF**

### 8.1 Powering ON the SBR30

1. Turn the 24V disconnect to the ON position
2. Turn System Key to the ON Position Set the 24V Battery Disconnect to the ON position.
3. Hit ACCEPT on the HMI screen.
4. Use the voltage selector switch to set operating voltage
5. The Control Screen displays “Waiting for Inverter”. This will take between 30-60 seconds as the inverter powers up.
6. Verify Cam-Lock breakers are in the closed (up) position.
7. LEDs on both DEIF CONTROLLERS will flash as the controllers power up.
8. The Control Screen displays the Power-On Selection Mode screen.
9. The SBR30 is powered and ready to operate.

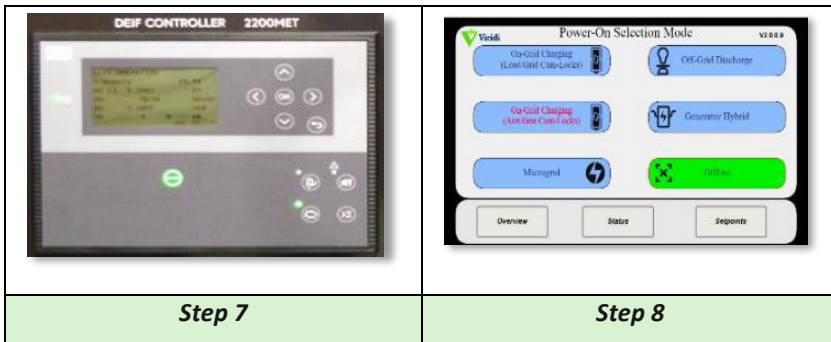
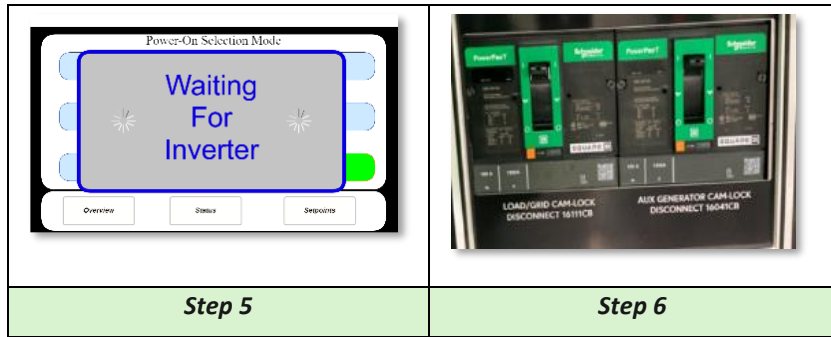

### 8.1.1 On-Grid Charging Installation and Operation

1. Connect Grid Camlocks to the LOAD/GRID receptacles (left side).
2. Verify all breakers are closed.
3. Set the Transfer Switch to the correct voltage setting.
4. On the Power-On Selection Mode screen, select On-Grid Charging (Load/Grid Cam-Locks).
5. On the pop-up menu, confirm the transfer switch setting.
6. On the next pop-up menu, confirm the load is set up for the selected voltage.
7. You will hear the contactor close, allowing power to flow from the grid to the SBR30.
8. Verify the *System Live* light is on
9. Power flow can be verified on the Overview screen.

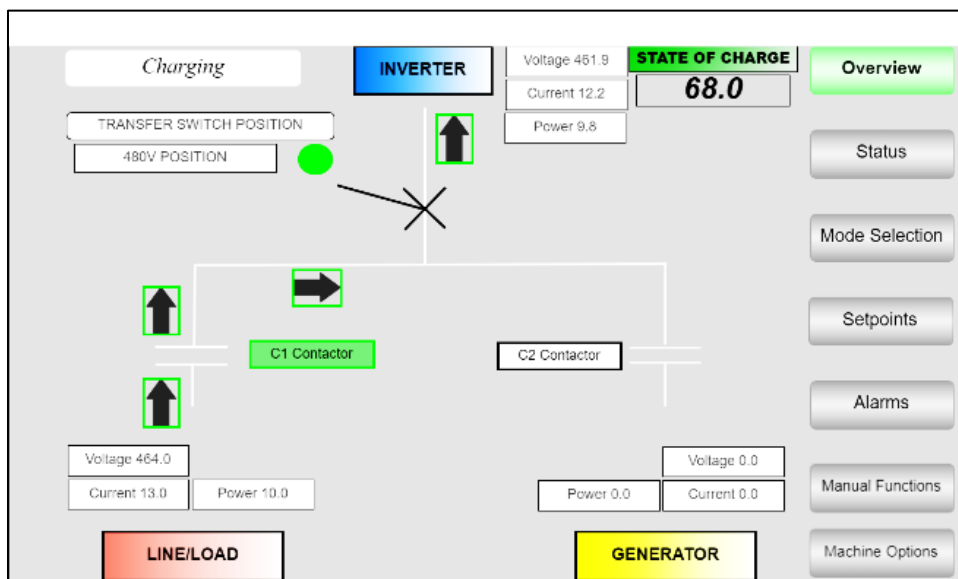

10. Meter readings can be viewed in real-time on the Status Screen.

**Note:** All of this is applicable to Aux/Gen Camlocks

## 208V SELECTION

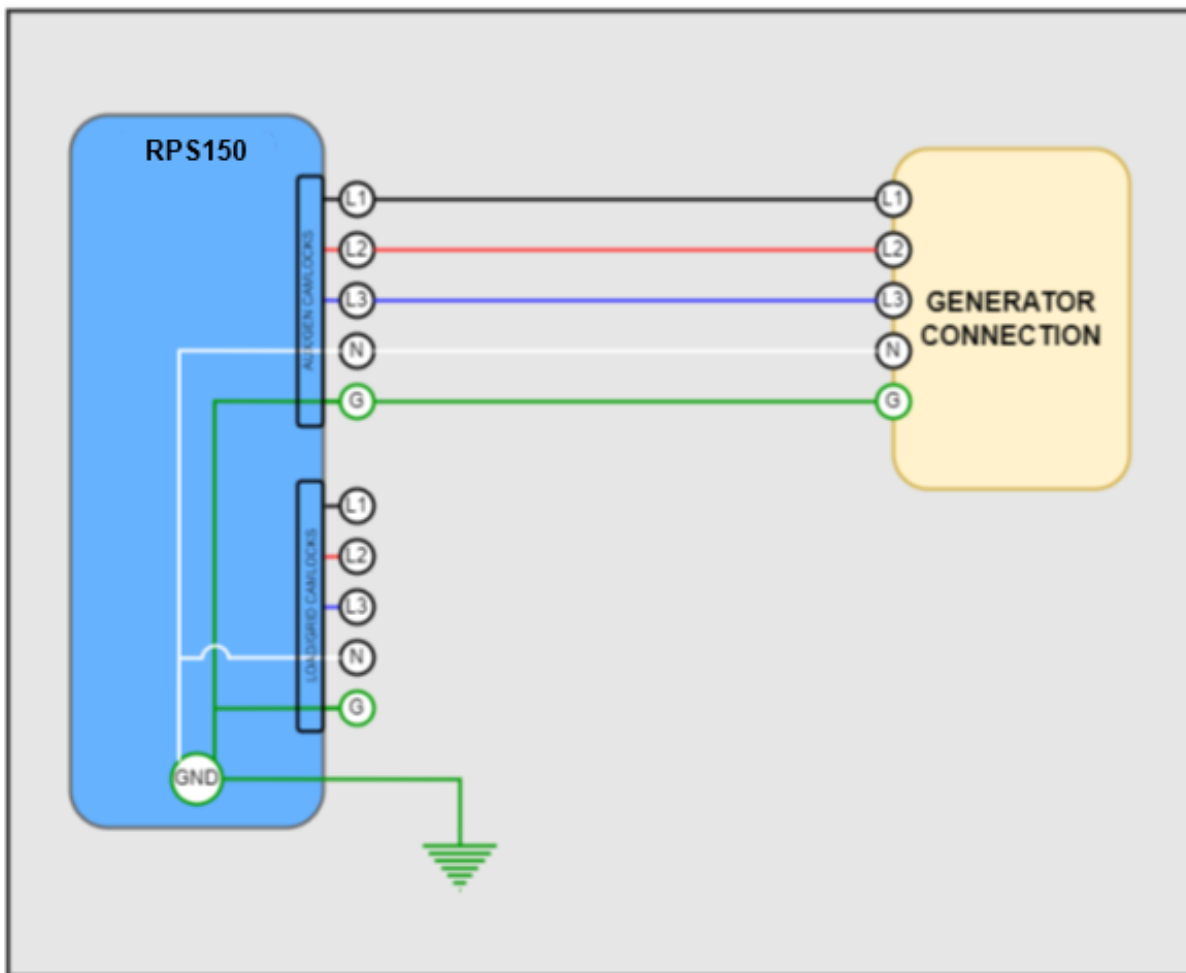

## ON-GRID CHARGE AUX/GEN CAMLOCKS

- NEC (National Electrical Code, 2023 edition, Article 250.53(B)):
  - Ground rods must be separated by at least 6 feet.
- CSA (Canadian Standards Association, 2023 edition, Rule 10-102 (2)):
  - Ground rods must be separated by at least 3 meters and driven at least 3 meters into the ground.

## 480V SELECTION

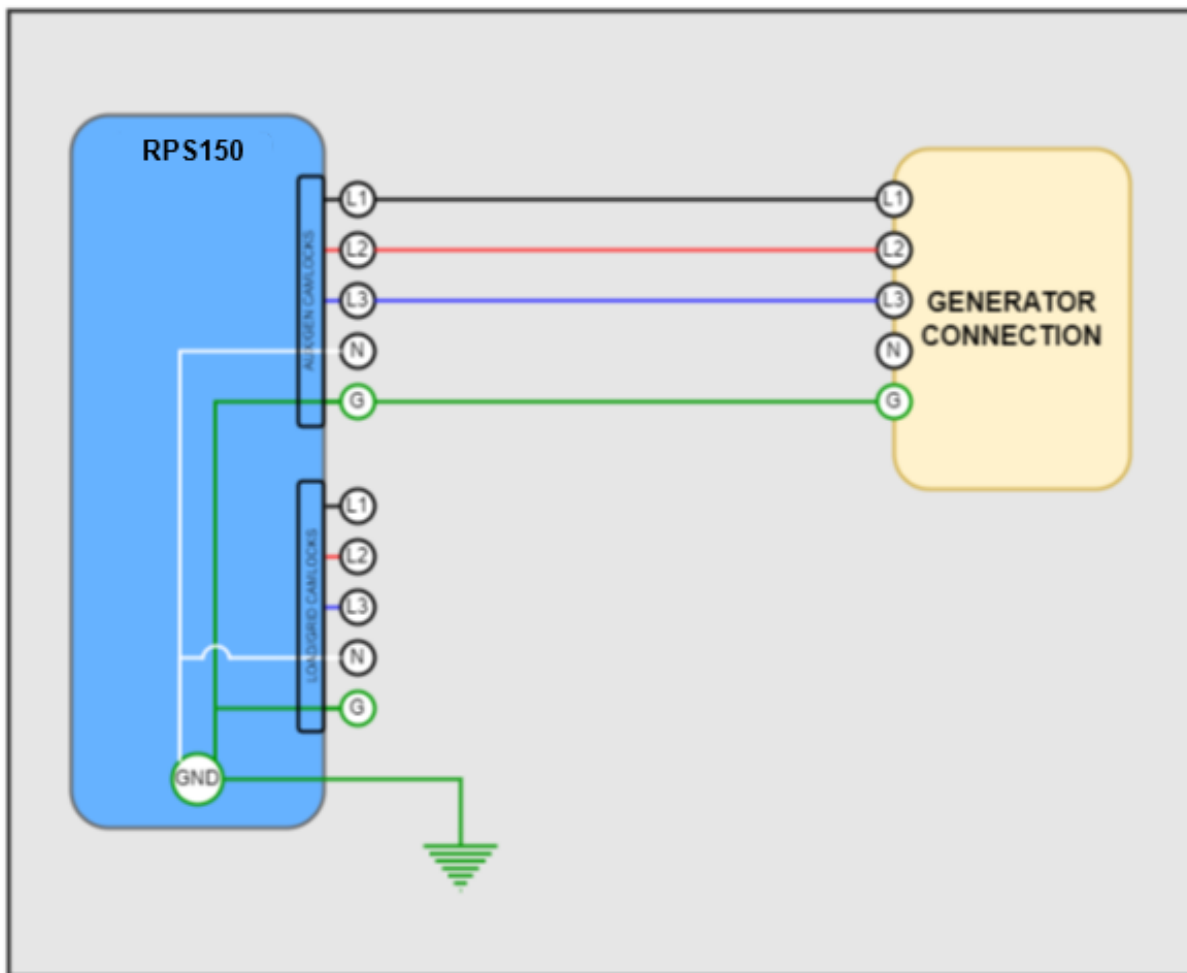

## ON-GRID CHARGE AUX/GEN CAMLOCKS

- NEC (National Electrical Code, 2023 edition, Article 250.53(B)):
  - Ground rods must be separated by at least 6 feet
- CSA (Canadian Standards Association, 2023 edition, Rule 10-102 (2)):
  - Ground rods must be separated by at least 3 meters and driven at least 3 meters into the ground.
- Neutral not available in 480V mode.

## 208V SELECTION

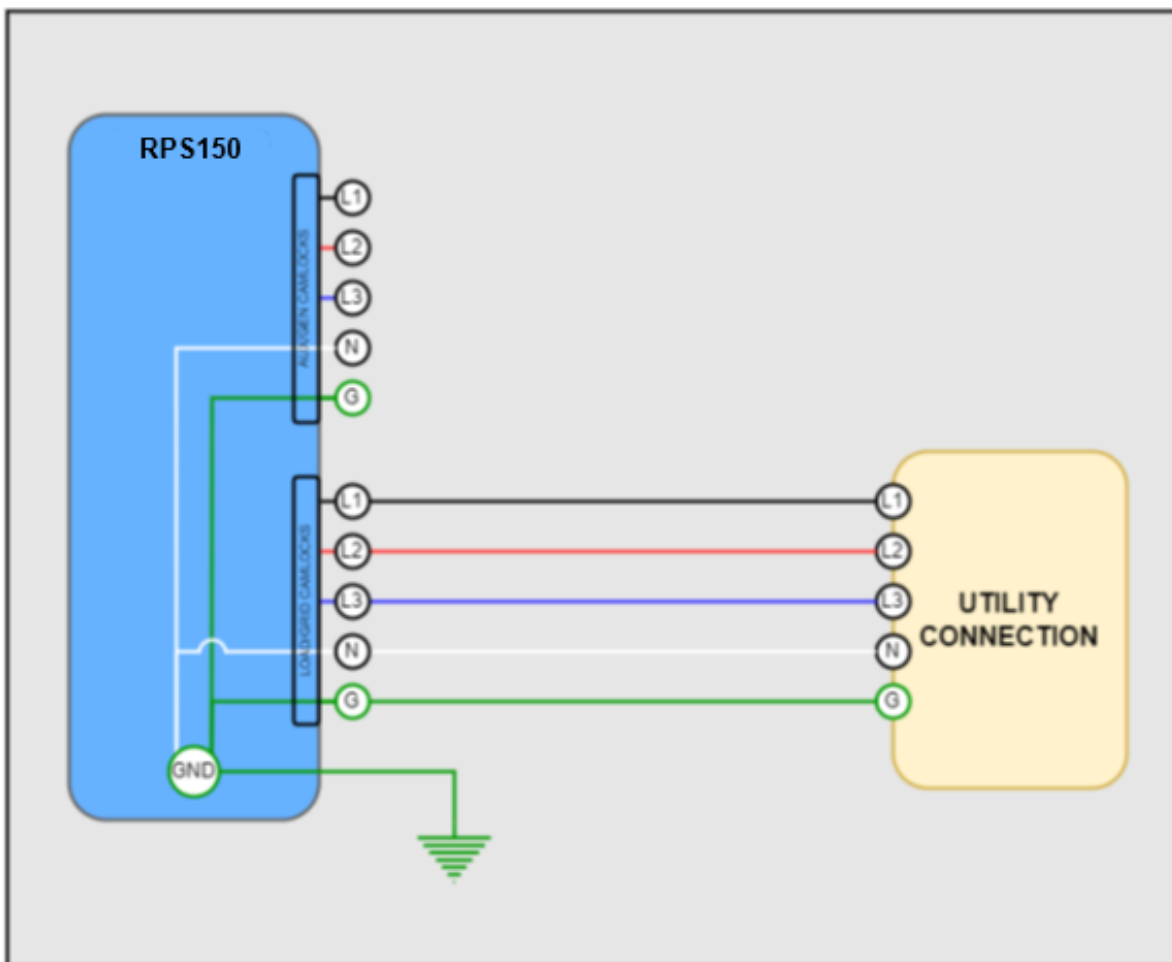

## ON-GRID CHARGE/DISCHARGE LOAD GRID CAMLOCKS

- NEC (National Electrical Code, 2023 edition, Article 250.53(B)):
- Ground rods must be separated by at least 6 feet.
- CSA (Canadian Standards Association, 2023 edition, Rule 10-102 (2)):
- Ground rods must be separated by at least 3 meters and driven at least 3 meters into the ground.

## 480V SELECTION

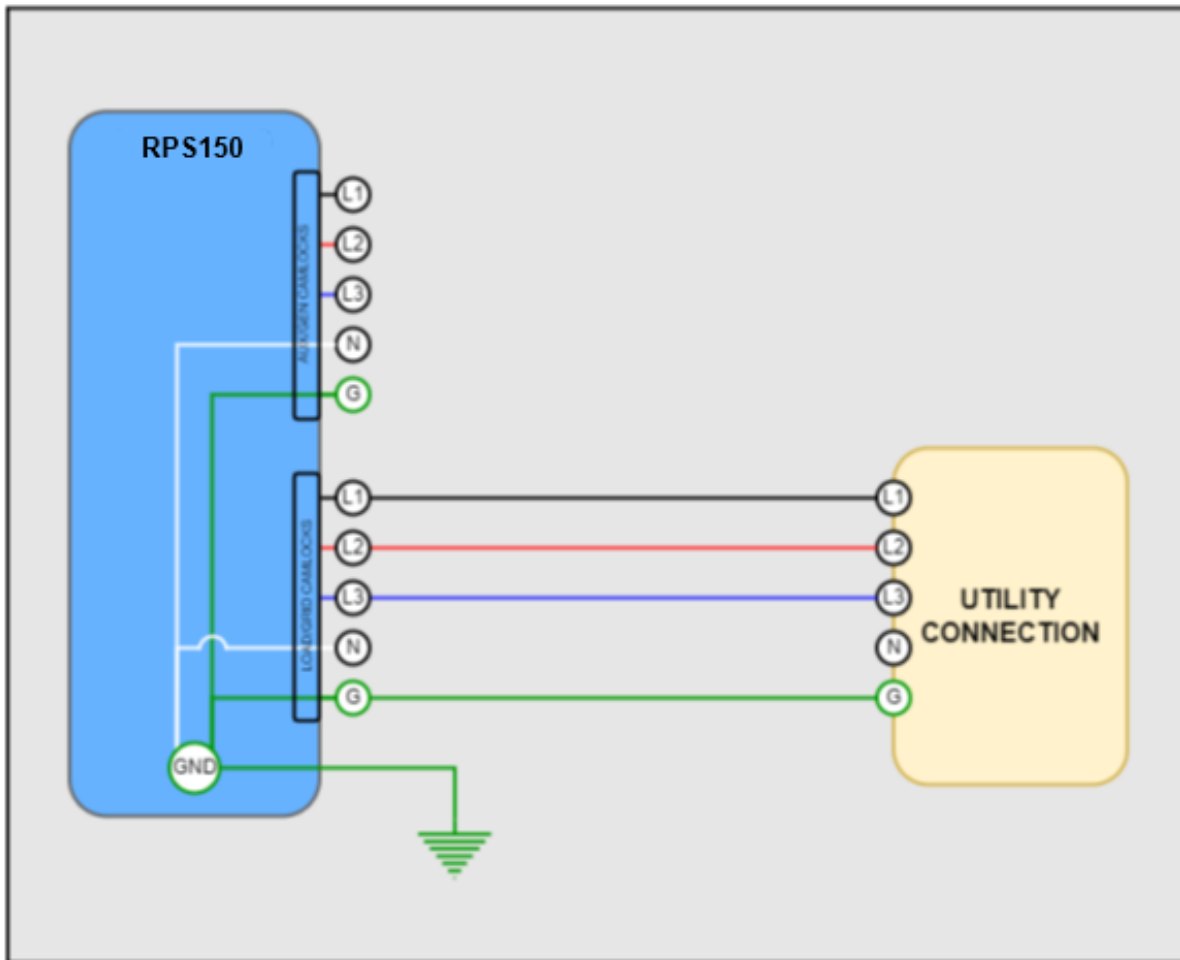

## ON-GRID CHARGE/DISCHARGE LOAD GRID CAMLOCKS

- NEC (National Electrical Code, 2023 edition, Article 250.53(B)):
  - Ground rods must be separated by at least 6 feet.
- CSA (Canadian Standards Association, 2023 edition, Rule 10-102 (2)):
  - Ground rods must be separated by at least 3 meters and driven at least 3 meters into the ground.
- Neutral not available in 480V mode.

## 8.2 Off-Grid Discharge Installation & Operation

### 8.2.1 Setup

1. Determine whether the desired load is 208 Volts 3 phase, or 480 Volts 3 phase.
2. Attach the appropriate Cam-Lock Cables to the Load/Grid Cam-Locks. (Left side)

**NOTE:** 480 Volts 3 Phase will **NOT** use neutral cam lock cables (shown in 1.2).

3. Set transfer switch to voltage determined in step 1.



Reference  
Paragraph 8.2.1,  
step 2



Reference  
Paragraph 8.2.1,  
step 3

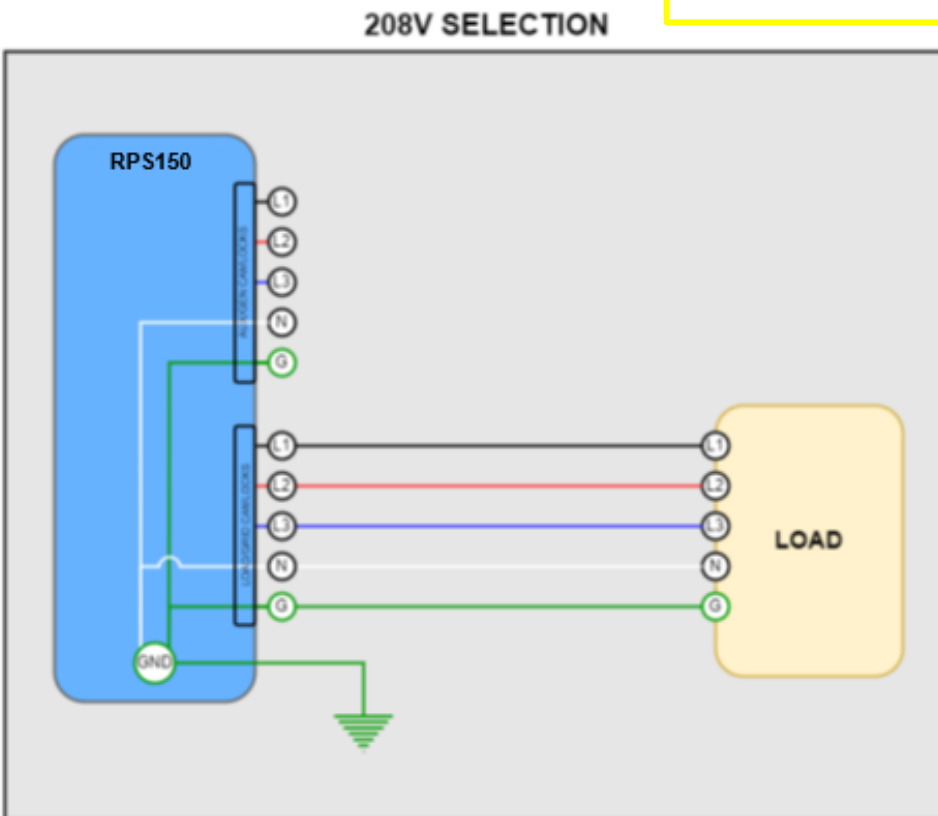

**OFF-GRID DISCHARGE**

- NEC (National Electrical Code, 2023 edition, Article 250.53(B)):
  - Ground rods must be separated by at least 6 feet.
- CSA (Canadian Standards Association, 2023 edition, Rule 10-102 (2)):
  - Ground rods must be separated by at least 3 meters and driven at least 3 meters into the ground.

## 480V SELECTION

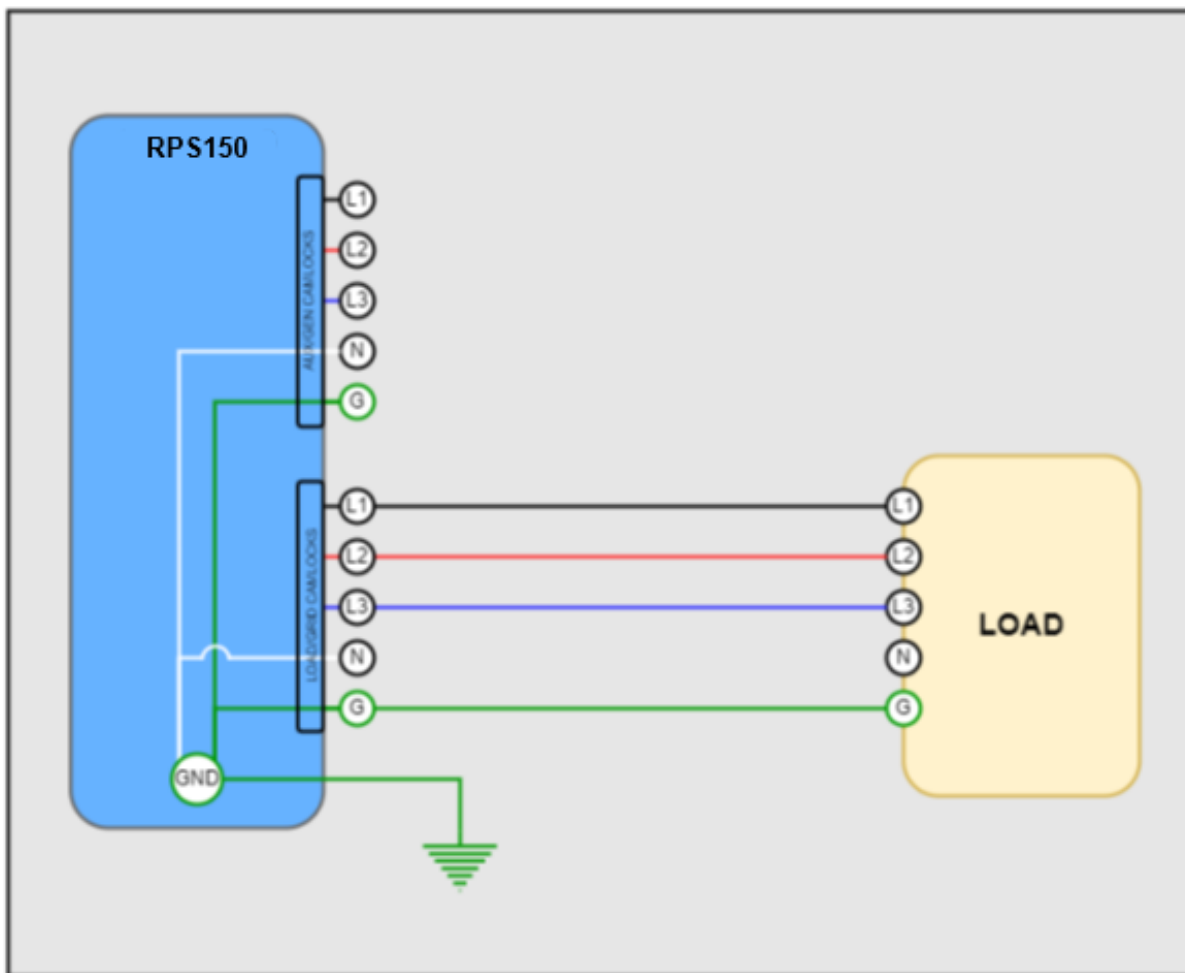

## OFF-GRID DISCHARGE

- NEC (National Electrical Code, 2023 edition, Article 250.53(B)):
  - Ground rods must be separated by at least 6 feet.
- CSA (Canadian Standards Association, 2023 edition, Rule 10-102 (2)):
  - Ground rods must be separated by at least 3 meters and driven at least 3 meters into the ground.
- Neutral not available in 480V mode.

### 8.2.2 Select Mode

- Select Off-Grid Discharge on the displayed screen.

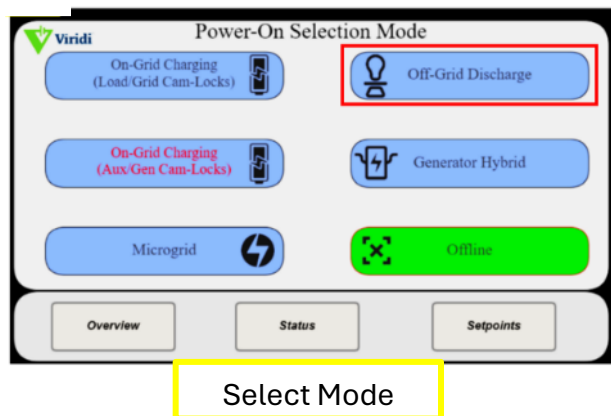

### 8.2.3 Confirm Output Voltage

- Confirm desired output voltage matches voltage selector switch and click **Yes – Continue**.

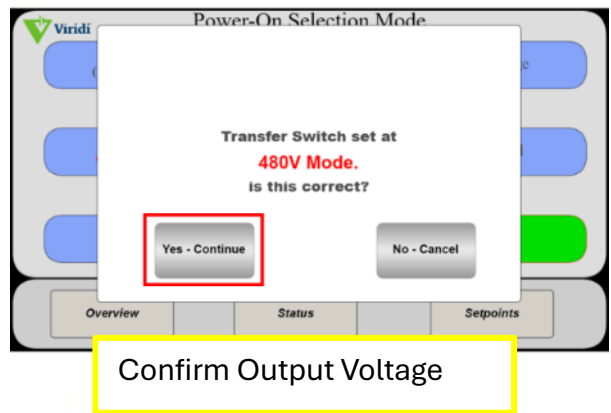

### 8.2.4 Confirm Load Voltage

- Confirm the load is setup for the desired output voltage based on voltage selector switch. If everything matches click **Yes – Continue**.

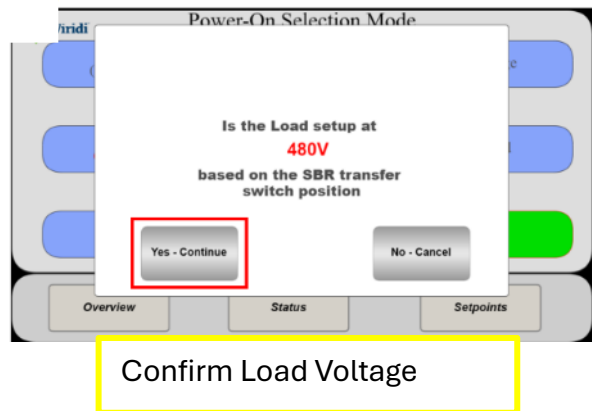

## 8.2.5 Verify Operation

- a. The SBR30 is now supplying the load.  
Click **Overview** to verify power flow.

### 8.2.5a

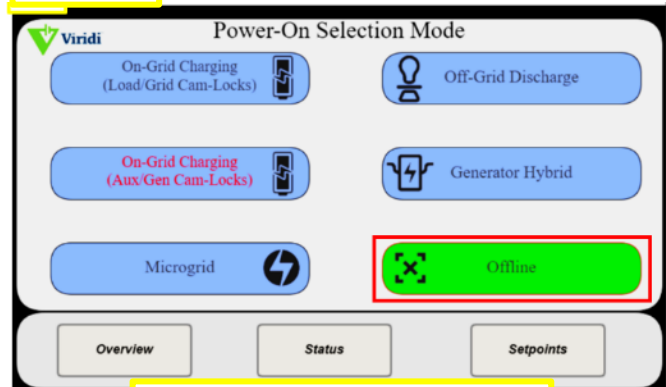

Verify Operation

- b. If the green arrows are moving from the inverter to the Line/Load you're supplying power to the Line/Load.

### 8.2.5b

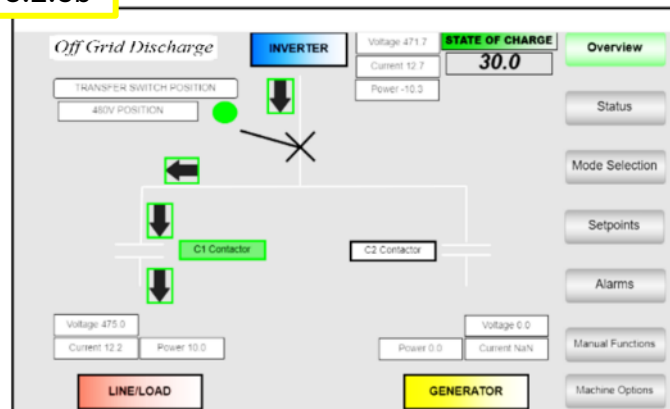

Power Being Supplied

### 8.3 Generator Hybrid Installation

- Determine what KW output the generator is and what the voltage of the setup will be so the generator can be set to output the correct voltage:
  - 208 Volts 3 phase
  - 480 Volts 3 phase
- Attach the generator Cam-Lock Cables to the Aux/Gen (right side) Cam-Lock ports on the SBR30 and attach the load to the Load/Grid (left side) Cam-Locks.



- Set transfer switch to voltage determined in step 1.

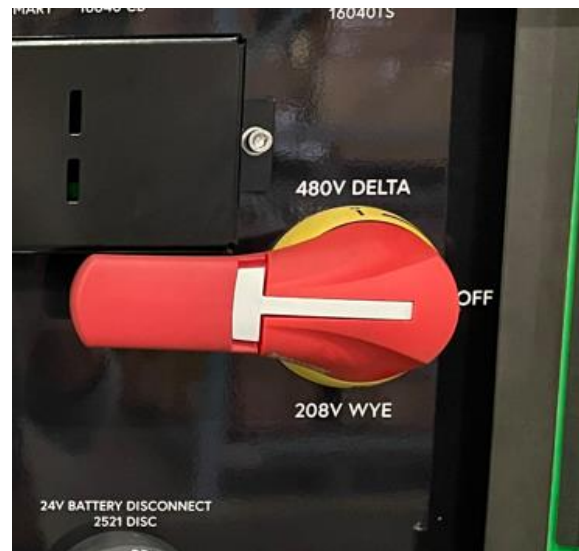

- Connect generator contact to allow syncing of phases and voltages.



## 208V SELECTION

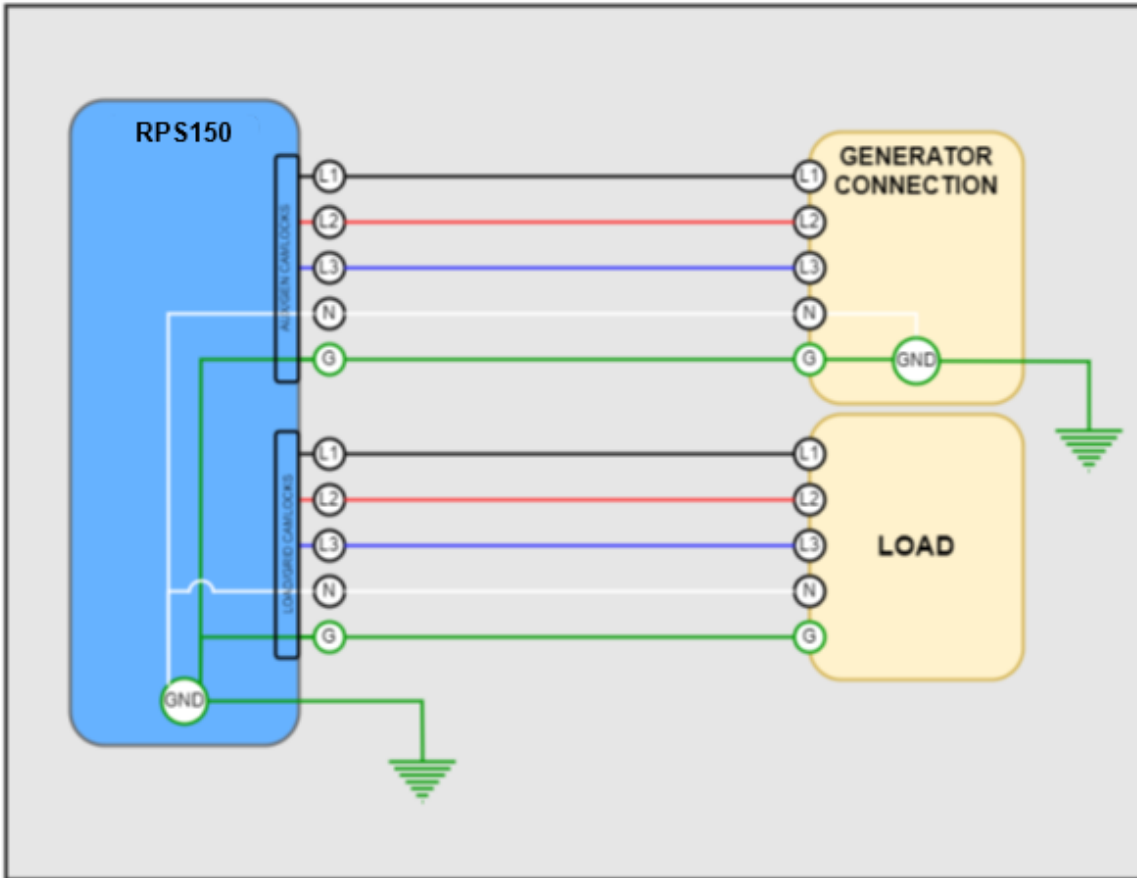

## GENERATOR HYBRID

- NEC (National Electrical Code, 2023 edition, Article 250.53(B)): Ground rods must be separated by at least 6 feet.
- CSA (Canadian Standards Association, 2023 edition, Rule 10-102 (2)): Ground rods must be separated by at least 3 meters and driven at least 3 meters into the ground.

### 480V SELECTION

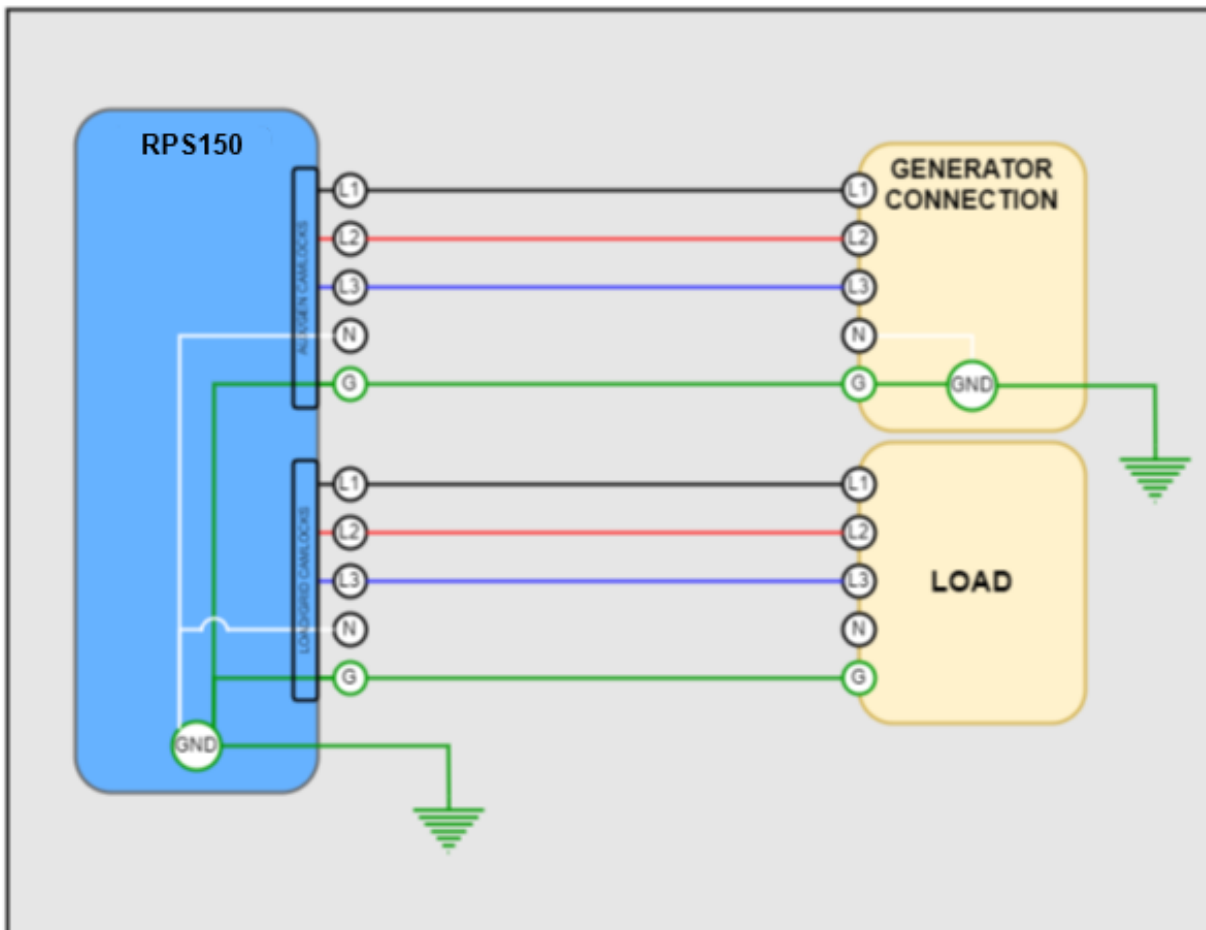

### GENERATOR HYBRID

- NEC (National Electrical Code, 2023 edition, Article 250.53(B)):
  - Ground rods must be separated by at least 6 feet.
- CSA (Canadian Standards Association, 2023 edition, Rule 10-102 (2)):
  - Ground rods must be separated by at least 3 meters and driven at least 3 meters into the ground.
- Neutral not available at 480V.

## 8.4 Generator Hybrid Operation

### 8.4.1 Turn on the SBR30 (See powering on the SBR30)

### 8.4.2 Select Mode

- Select **Generator Hybrid** mode on the Power-On Selection Mode screen.

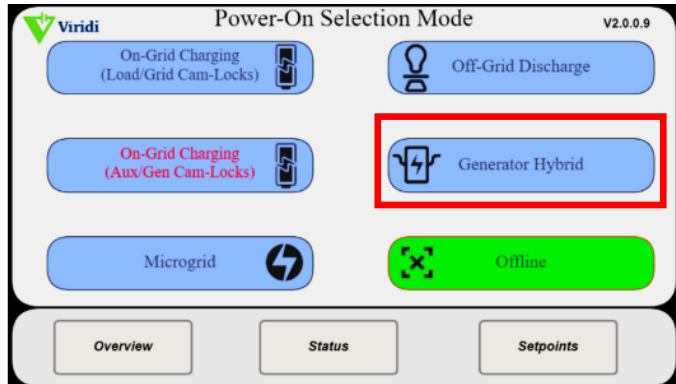

### 8.4.3 Confirm Output Voltage

- Confirm desired output voltage matches voltage selector switch and click **Yes – Continue**.

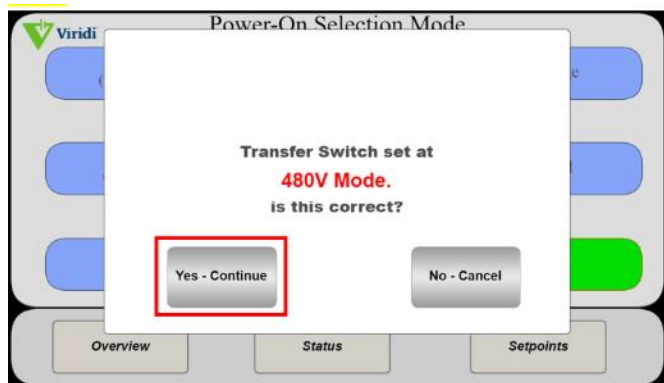

### 8.4.4 Confirm Load Voltage

- Confirm the load is setup for the desired output voltage based on voltage selector switch. If everything matches click **Yes – Continue**.

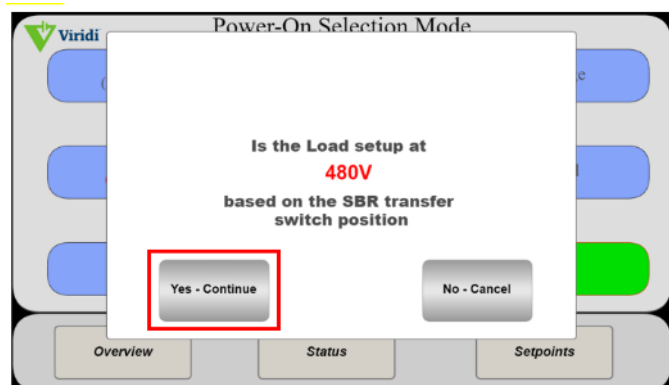

### 8.4.5 Input Generator Size

- Click **Gen Size Connected** to change the size of the generator determined in step 1 of Generator Hybrid installation.

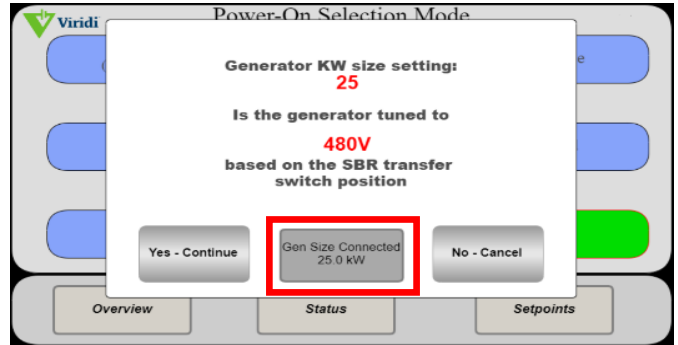

### 8.4.6 Input Generator KW

- Input generator KW and click **OK**.

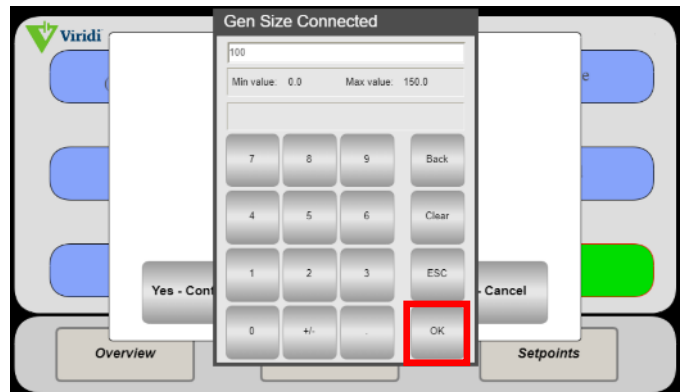

### 8.4.7 Accept Generator Size

- Confirm KW shown matches KW output of generator and click Yes – Continue.

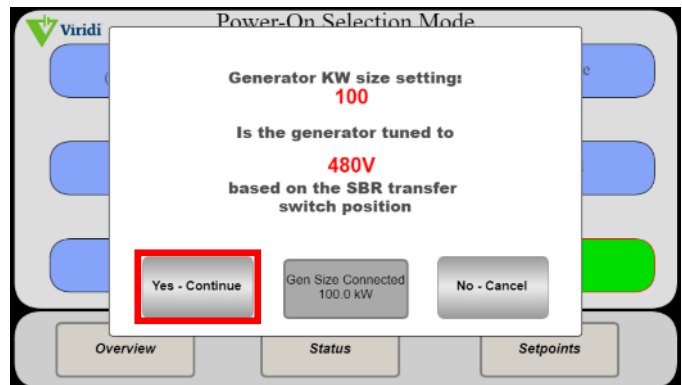

### 8.4.8 Generator Hybrid Mode

- The SBR30 is now in Generator Hybrid mode. Click **Overview** to verify power flow.

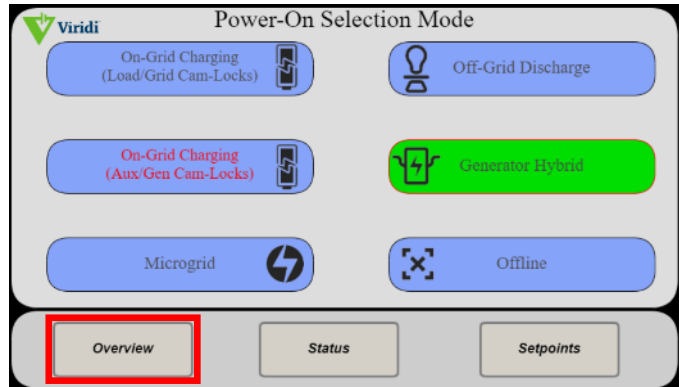

### 8.4.9 Verify Operation

- Power flow can be seen on Overview screen.
  - This is the screen showing the generator is idle.

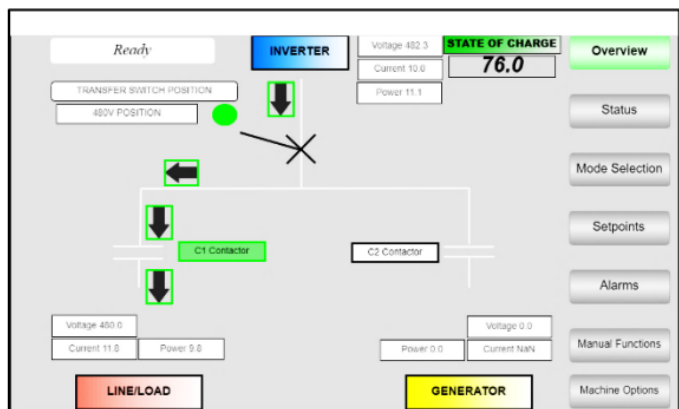

*Generator Idle*

- This is the screen showing the generator is ON and Charging the SBR30 unit.

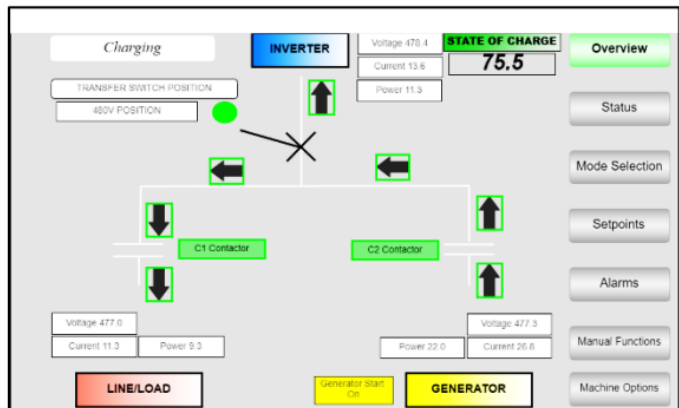

*Generator ON*

## 8.5 Microgrid Installation

This installation typically has two or more SBR30 linked together with one or more generators to a common bus or I-Line Panel. Here is an example wiring diagram:

### Wiring Diagram

2 GEN 4 BESS Microgrid application example below.

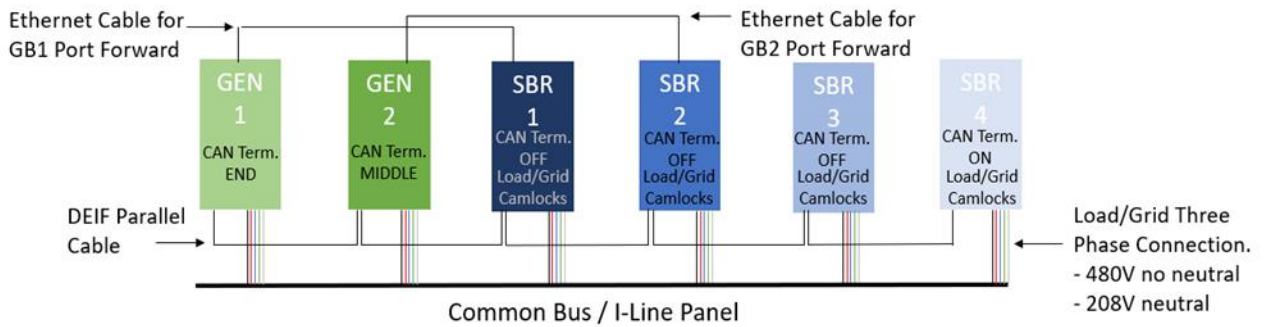

### 8.5.1 Step by step physical set up of the microgrid following the wiring diagram

- Determine what type of power the generator is going to output and what type is needed to supply the load:
  - 208 Volts 3 phase
  - OR
  - 480 Volts 3 phase

**NOTE:** The SBR30 will not supply 277V. If 277V is needed for the final output voltage, an external transformer will be required.

- Attach Cam-Lock Cables from the Load/Grid (left side) Cam-Lock ports on each BESS to the Common Bus or I-Line Panel.
- Attach Cam-Lock Cables from each generator(s) to the Common Bus or I-Line Panel.



## 4. Review Common Bus set up:

- a) The power sources terminating at the Common Bus may require turn around connections.
- b) Ensure the breakers used are the appropriate amp rating.
- c) It's recommended to label each connection and breaker with the device ID or asset #.

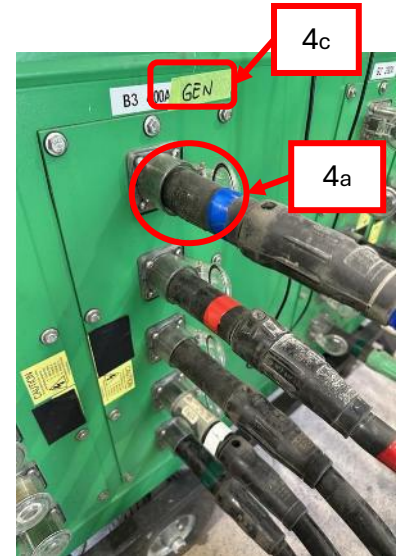

5. Set transfer switch on all BESS to the voltage determined in step 1.



## 208V SELECTION

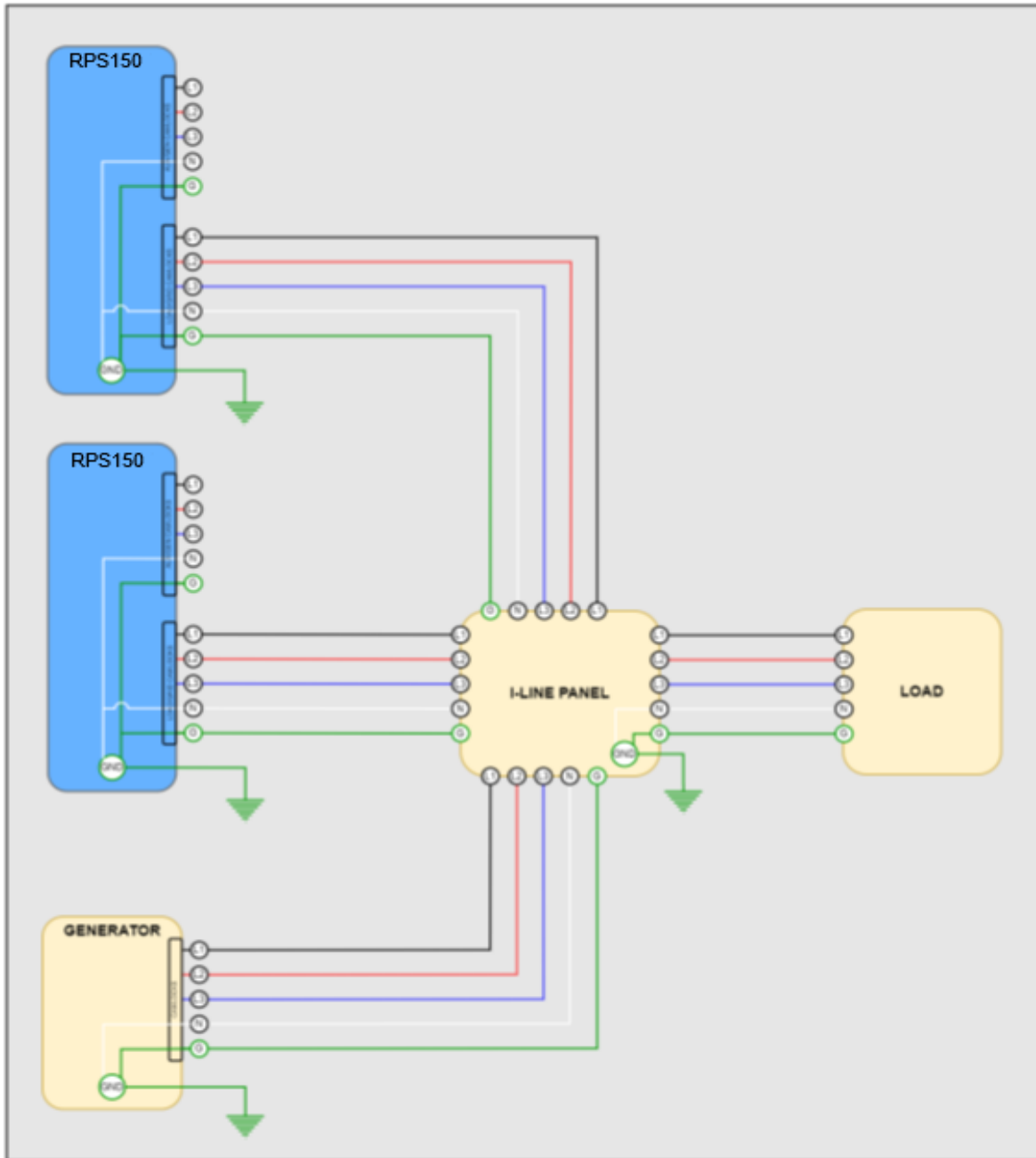

## MICROGRID SETUP

- NEC (National Electrical Code, 2023 edition, Article 250.53(B)):
  - Ground rods must be separated by at least 6 feet.
- CSA (Canadian Standards Association, 2023 edition, Rule 10-102 (2)):
  - Ground rods must be separated by at least 3 meters and driven at least 3 meters into the ground.

## 480V SELECTION

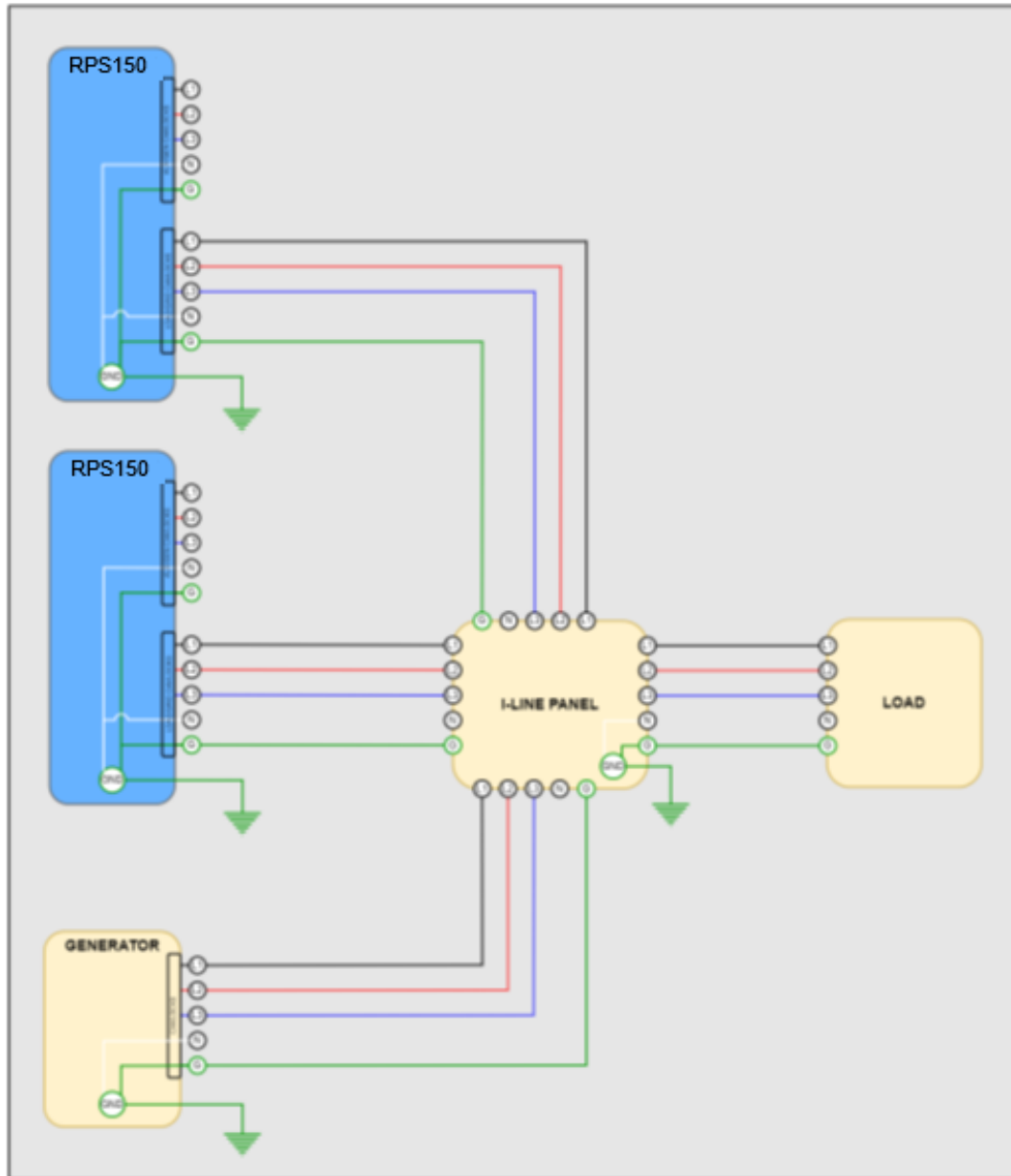

## MICROGRID SETUP

- NEC (National Electrical Code, 2023 edition, Article 250.53(B)):
  - Ground rods must be separated by at least 6 feet.
- CSA (Canadian Standards Association, 2023 edition, Rule 10-102 (2)):
  - Ground rods must be separated by at least 3 meters and driven at least 3 meters into the ground.
- Neutral not available in 480V mode.

## 8.5.2 Physical Set Up

How to set up DEIF Paralleling Cable following the Wire Diagram.

1. First Device in 'line' is Generator 1. Attach the DEIF Parallel cable to the 'OUT' port.

Set the Parallel Signal Switch to 'END'.



2. Middle Devices in 'line' are additional generators and BESS. Daisy chain the parallel cable from the 'OUT' port on the previous device to the 'IN' port on next device.

Set the DEIF Canbus Terminator Switch to 'OFF' on the middle devices.

3. Make sure the last Device in 'line' is a BESS. Attach the DEIF parallel cable to the 'IN' port.

Set the DEIF Canbus Terminator Switch to 'ON' on this last device.

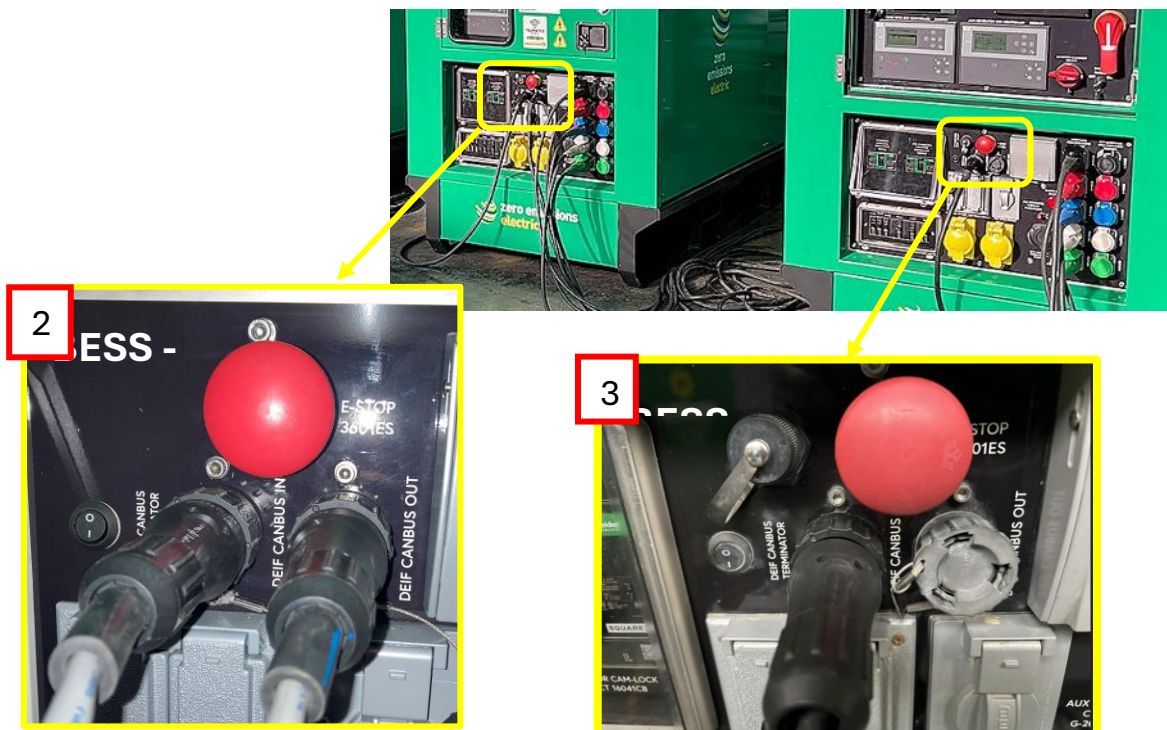

## 8.6 Microgrid Operation

### 8.6.1 How to start the Microgrid

1. All units should read “Ready Island Auto”
2. To run the microgrid:
  1. Ensure there are no faults.
  2. Ensure all devices are in auto mode, including generator(s).
  3. **Start** the system from the Generator TDU by pressing the start button.
  4. Put BESS units in **Microgrid Mode** on HMI Mode Selection screen.
    - 4.1. Voltage is now present; BESS System Live Light should illuminate
    - 4.2. If there is no voltage seen, check the breakers
  5. The user must **log into the DEIF controller** to configure and broadcast their **application setup** before operation.
3. Verify on DEIF Application Supervision that all devices are synced in, reading ‘Island Active’ and no alarms present.
  1. Example indicates GB1 charging all 4 BESS (100KW) plus supplying 34KW of power to load. GB2 not synced in – breaker open, 0 voltage, yellow indicates not in auto.

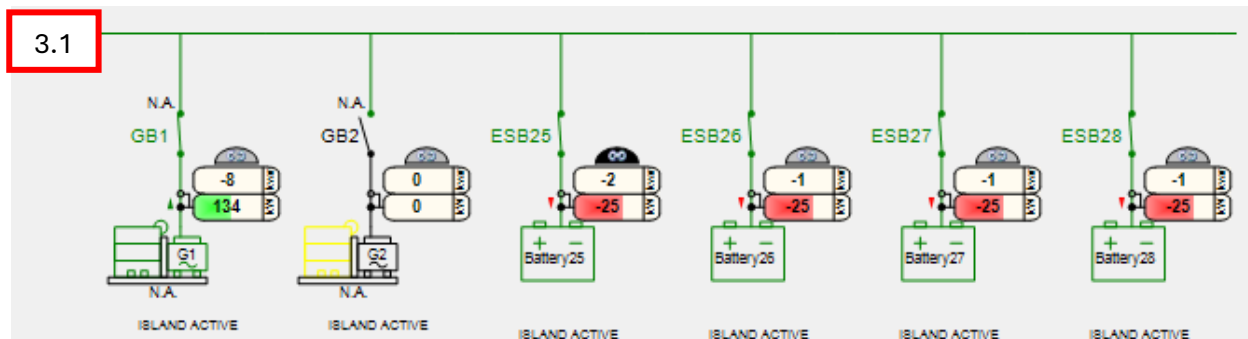
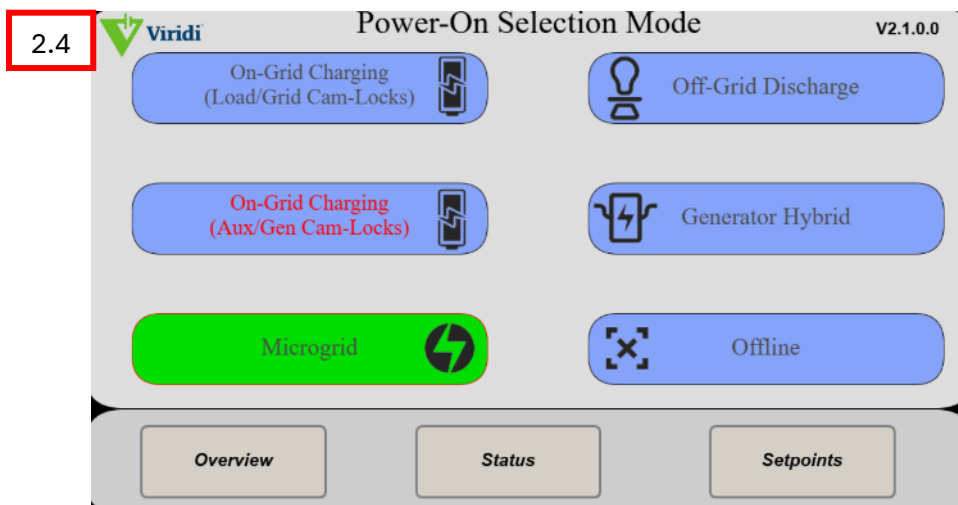

### 8.6.2 How to verify functionality on HMI

1. Check Overview Screen
  1. C1 Contactor green = closed breaker.
  2. Green arrows flowing on left side TO Line/Load.
  3. Green arrow pointing away from inverter = discharging.
  4. Green arrow pointing towards inverter = charging.
  5. Voltage, Current, Power data seen on Inverter AND Line/Load.
  6. Transfer Switch Position in correct mode with Green Dot.

*NOTE: If green arrows differ from this or are not present, check all breakers and connections on BESS and Common Bus.*
7. Navigate to Setpoints → Microgrid Program Setpoints.
8. Adjust the desired Maximum Charge KW and Maximum Discharge KW (note: Microgrid time of day).

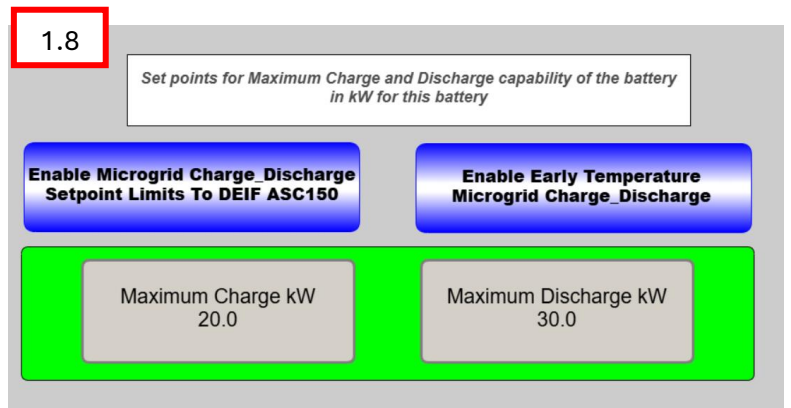
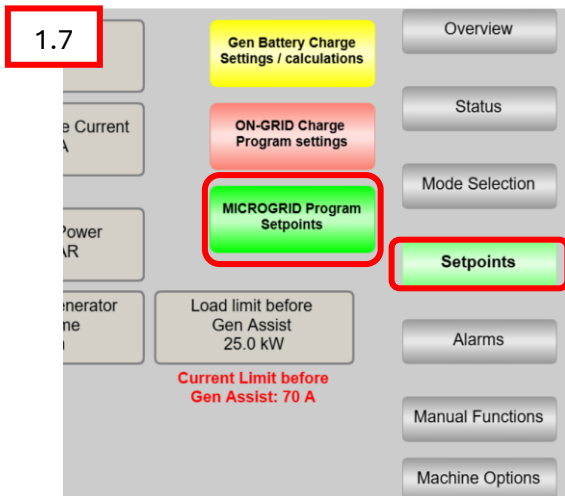
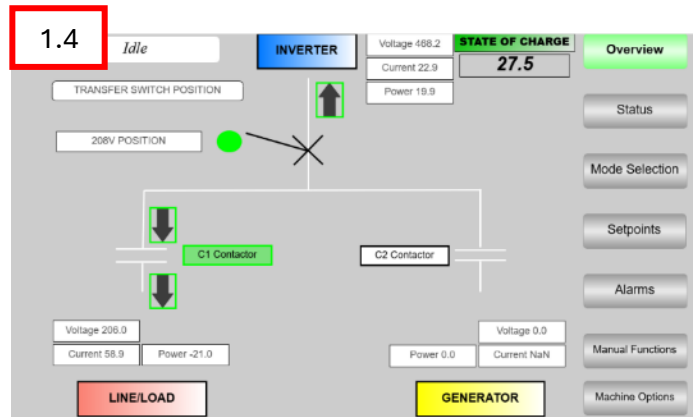
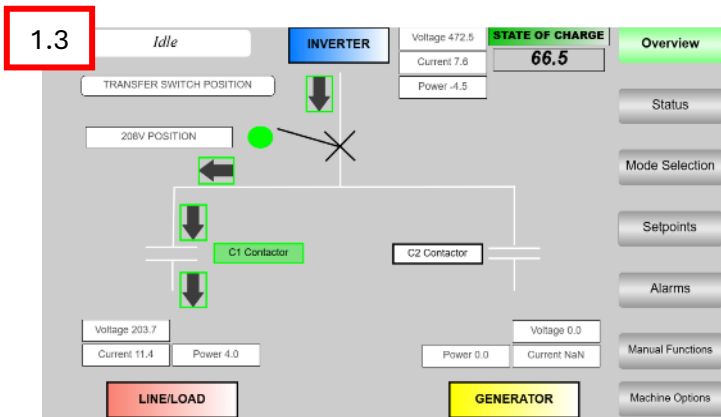

### 8.6.3 Servicing/Removing a BESS

#### How to remove a Battery Energy Storage System (BESS) from Microgrid Application without disrupting the grid.

1. Set the BESS unit from Microgrid to **Offline Mode** on HMI Mode Selection Screen.
2. Avoid disconnecting the CAN lines where possible.
3. Turn the voltage transfer switch to **OFF**.
4. Open the lower 150A breaker.
5. Turn off the power key and 24V Disconnect before servicing.
6. If CAM cables are being removed, open the breaker on the common bus.
7. When the unit is ready to be brought back into the grid, reverse steps above.
8. If a new unit is being brought into the grid, ensure the DEIF parameters match on the new unit.

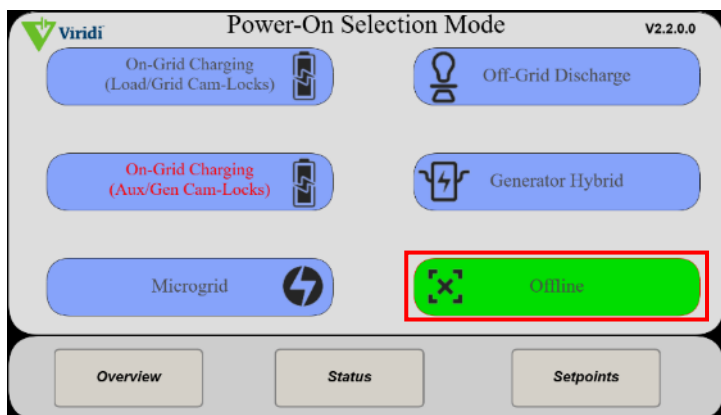

1



3



5

## 8.7 Powering Off

1. On the *Mode Selection* Screen, select OFFLINE.
2. Turn the key switch to the OFF position.
3. Set the 24V Battery Disconnect to the OFF position.

The SBR30 is powered off.

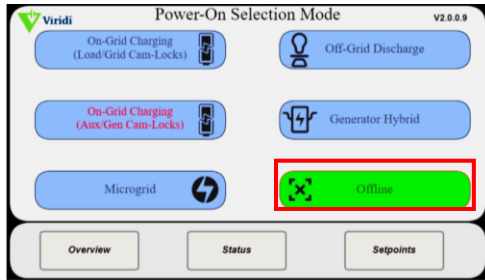

1



2



3

# MAINTENANCE & TROUBLESHOOTING



## 9. Maintenance

### Note:

- Unit must be completely disconnected from all external connections prior to any maintenance.
- For part numbers or replacement information, contact [service@viridiparente.com](mailto:service@viridiparente.com) or [parts@viridiparente.com](mailto:parts@viridiparente.com)

### 9.1 Cleaning

*While every effort has been made to ensure the accuracy of the content, the authors and publishers make no warranties, either express or implied, regarding the completeness or reliability of the information contained herein. Under no circumstances shall the authors, publishers, or any affiliated parties be liable for any direct, indirect, incidental, consequential, or punitive damages arising from the use or inability to use the information in these guidelines, even if advised of the possibility of such damages. By using this document, you agree to these terms and conditions.*

- DO NOT power-wash of any part of the unit
- DO NOT spray any part of the unit (with a hose or other instrument)
- DO NOT touch the battery caps or high-voltage electrical connections
- Hand wash user and electrical interface panels with an all-purpose cleaner and rag
- Hand wash roof, side panels, skid, and trailer with soapy water and sponge
- On vinyl-wrapped units, clean/shine outside with 90% rubbing alcohol. For damaged areas, repair with new vinyl.
- Tire shine or other automotive cleaners may be used on the trailer and tires

## 9.2 Maintenance Schedule

### 9.2.1 14-Day Service Interval Checklist

1. Verify no physical damage to the SBR30, its displays, connectors, or receptacles.
2. Check the twist latches and make sure they're secure, if not, tighten them.
3. Verify the Medium Ambient Intake and Exhaust fan is operating.
4. Inspect intake air filter and clean/replace as needed.
5. Verify all breakers are in the ON position.
6. Verify GFI functionality on GFI outlets by pressing TEST and RESET.
7. Verify minimum 22V on the lead acid batteries and recharge as needed.
8. Document maintenance performed.

### 9.2.2 3-month Service Interval Checklist

1. Replace intake air filters every 6 months for low dust applications.
2. Check the condition of all electrical parts.
3. Fix any problems that are found.
4. Document maintenance performed.



#### WARNING

- To prevent electric shock, Arc Flash, or equipment damage, all power sources must be safely disconnected and de-energized before performing any internal maintenance on the Battery Energy Storage System (BESS). This includes verifying 24VDC and key switch are in the OFF position, and the trickle charger is unplugged
- For part numbers or replacement information, contact [service@viridiparente.com](mailto:service@viridiparente.com) or [parts@viridiparente.com](mailto:parts@viridiparente.com)

### 9.3 Medium Ambient Filter Change

1. To Change the Medium Ambient Intake air filter, take the following steps:
  - a. Unscrew the wing nut on the top of the metal cover
  - b. Remove the metal cover
  - c. Remove the filter
  - d. Replace the filter with a new filter
  - e. Replace the metal cover
  - f. Secure the metal cover by reinstalling the wing nut
2. Contact references: [parts@viridiparente.com](mailto:parts@viridiparente.com) or [service@viridiparente.com](mailto:service@viridiparente.com) for replacements



Wing Nut



Metal  
Cover

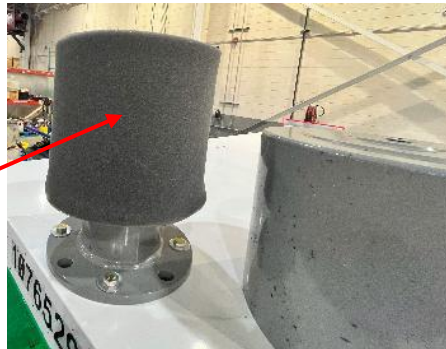

Replaceable  
Filter Cover Sock



## 9.4 Troubleshooting

If the SBR30 is not functioning, check the following:

- Verify **24V battery disconnect** is ON.
- Verify **key switch** is ON.
- If no display power, check **12V batteries**.
- If unit is stuck on “Waiting for Inverter,” check **E-Stop and Key Cycle**.

If issue persists, contact [service@viridiparente.com](mailto:service@viridiparente.com)

## 9.5 Trailer

The tandem axel heavy duty trailer has been designed to comply with all US and Canadian road commercial laws and guidelines. Here are some of the common alarms, their severity, and a brief explanation along with the action needed to resolve them.

Note:

1. Not all trailers include a **12V breakaway system**; users must inspect for the presence of the kit before performing the check.
2. Viridi trailers may use **hydraulic or electric brake systems**. Verify the type before proceeding with inspections.

### 9.5.1 Warnings

Compliance with the following warnings are mandatory:

1. The Trailer is not to be towed unless brakere are working and safety chains are securely attached to the towing vehicle.
2. Note that not all trailers include a **12V breakaway system**; users must inspect for the presence of the kit before performing the check.
3. Tire inflation: Inflate tires to recommend inflation. This information is found on the tire wall.
4. Always close hitch before towing, check daily for wear or distortion is advisable.
5. The following visual checks are mandatory:
  - a. All parts, bolts and fasteners are tight
  - b. The load is properly secured into trailer
  - c. Tires are properly inflated
  - d. Electrical Connections and their operation are functional
    - i. Marker (running) Lights
    - ii. Break Lights
    - iii. Turn Indication Lights
    - iv. Hazard Lights
  - e. Brakes are functioning properly in accordance with US and/or Canadian highway laws
  - f. The safety chains are properly secured
  - g. The hitching mechanisms are secure

- h. The front jack is raised and properly secured
- i. The front crank handle is secured
- j. Lugs are tightened in the sequence and properly torque as listed below:



### 9.5.2 Periodic Maintenance Checks

Perform the following at stated intervals

Function Required	Every Week	The lesser of 3 months or 3,000 miles	The lesser of 6 months or 6,000 miles	The lesser of 12 months or 12,000 miles
<b>Wheels:</b> Inspect for cracks, dents or distortion			X	
<b>Tire Inflation Pressure:</b> Inflate tires to manufactures specification (reference tire sidewall). Visually inspect every tire – every trip	X			
<b>Tire condition:</b> Inspect for cuts, wear patterns, and broken or frayed belts.	X			
<b>Trailer Lights and Wiring:</b> verify all lights are functional.	X			
<b>Brakes:</b> Test that the braking system is functional/operational. <b>(CRITICAL)</b>	X			
<b>Brake Adjustment:</b> Adjust to proper operating clearance.		X		
<b>Brake Magnets:</b> Inspect that brake magnets are operational.			X	
<b>Brake Linings:</b> Inspect for wear.				X
<b>Electric Brake Controller:</b> check all wheels have brakes. All wheels should lock during brake control test.	X			
<b>Hydraulic Brake Cylinders:</b> check for leaks, sticking.				X
<b>Hydraulic Brake Hoses:</b> Inspect for cracks, leaks and kinks.				X
<b>Breakaway System (Optional):</b> check battery charge and switch operation.	X			
<b>Hub / Drum:</b> Inspect for extreme wear or scoring.				X

Function Required	Every Week	The lesser of 3 months or 3,000 miles	The lesser of 6 months or 6,000 miles	The lesser of 12 months or 12,000 miles
<b>E-Z Lube Axles, Wheels Bearings and Caps:</b> Inspect for corrosion or wear. Add grease to EZ Lube Axle – Pump grease gun 8 to 10 times to ensure bearings are properly greased.		X	X	X
<b>Seals:</b> Inspect for leakage. Replace the seals if necessary.				X
<b>Springs:</b> Inspect for wear, cracks, or loss of arch.				X
<b>Suspension Parts:</b> Inspect for bending, loose fasteners and shackle strap ware.			X	
<b>Hangers:</b> Inspect welds and hardware.				X
<b>Doors, Ramps and Gates:</b> Check latching function in open and closed positions.	X			

### 9.5.3 Trailer Contact information

For direct Trailer contact Information:

SteelPoint (Formerly MMDI)

200 Beltway Blvd,

Matthews, NC 28104

704-882-4550 x 2011 Office

Steel-Point.com

## 9.6 ViSTA Alarm Definition Glossary

Severity	Description	High Level Definition
<b>Critical</b>	High Impact to Functionality	<ul style="list-style-type: none"> <li>• An event that can cause the unit, or the "grid" to shut down</li> <li>• Requires Immediate Attention</li> <li>• Max cell voltage is too high</li> <li>• Max cell voltage is too low</li> <li>• High Temperature Reached</li> <li>• Low Temperature Reached</li> <li>• E-stop pressed</li> <li>• High Voltage Interlock – Not Functioning</li> </ul>
<b>Major</b>	High Impact to Functionality	<ul style="list-style-type: none"> <li>• An event that can cause the unit, or the "grid" to shut down</li> </ul>
	May not require attention	<ul style="list-style-type: none"> <li>• An event that can cause the unit, or the "grid" to shut down</li> <li>• Battery over temp (open contactor)</li> <li>• Max cell voltage is too high</li> <li>• Max cell voltage is too low</li> <li>• Skid offline</li> <li>• 24V battery below 24V (potential starter issues)</li> <li>• SBR30 inverter offline</li> <li>• LTE communications expected, however none exists</li> </ul>
<b>Minor</b>	Moderate impact to functionality but unit is still operating	<ul style="list-style-type: none"> <li>• An event that impacts overall functionality of the BESS but does not shut down.</li> <li>• High Temperature Warning (de-rating)</li> <li>• Battery Over temp (de-rated performance)</li> <li>• No LTE communications (ideally not expected)</li> </ul>
<b>Warning</b>	Does not impact functionality but if this continues it could cause an alarm	<ul style="list-style-type: none"> <li>• Does not impact on the overall functionality but if this state continues, it will lead to an alarm (either minor, or/and major).</li> <li>• Battery over temp (not derated yet, but getting close)</li> <li>• 24V battery below DC/DC voltage</li> </ul>

## 9.7 Alarms

This reference table lists each system fault, the text or email notification the user will receive, the corresponding alarm displayed on the SBR30 HMI, and the required action to address the issue. Users can rely on this table to identify a fault quickly and determine the correct operational or service response.

Alarm Notification (Text/Email)	HMI Alarm (SBR 30) Touchscreen)	Action
Pack Voltage Low	BMS Pack Voltage too Low unable to start	Connect to a charging source - Contact Viridi Service Department (Candapter Needed)
HighTemp Warning	SBR30 Battery Temp high: De-rating system	Battery is derating due to high temperature. Set fans to AUTO or ON.
HighTemp Error	SBR30 Battery Temp ERROR: System stopping charge	Battery shut down at 45 °C. Cool the unit and wait for temperature to drop. Power off to prevent 12 V battery drain.
High Temperature Warning	SBR30 Battery Temp high: De-rating system	Battery is derating due to high temperature. Set fans to AUTO or ON.
High Temperature Error	SBR30 Battery Temp ERROR: System stopping charge	Battery shut down at 45 °C. Cool the unit and wait for temperature to drop. Power off to prevent 12 V battery drain.
Low Temperature Warning	SBR30 Battery Temp Low: De-rating system	Battery is derating due to low temperature, ensure fan's are in the AUTO/OFF position.
Low Temperature Error	SBR30 Battery Temp ERROR: System stopping charge	Battery shut down at -10 °C. Warm the unit and wait for temperature to rise. Power off to prevent 12 V battery drain.
24V Battery Low	24VDC Lead Acid Battery Charge LOW!	Unit is ON but DC power is not detected for 1 V recharge. Key cycle the unit. If the issue persists, contact Viridi Service Department (Candapter may be required)
Emergency Stop Pressed	ESTOP PRESSED!! Reset ESTOP and Cycle power to machine	Reset both E-Stops and cycle power.
Generator Not Running	Auto Start Function does not work / Gen Start Failure	Generator failed to start or sync. Check the two-wire start circuit, verify generator maintenance status, and confirm generator voltage.
High Voltage Interlock Bypassed	High Voltage Interlock BYPASSED!!	HV system has been Bypassed - Contact Viridi Service Department
High Voltage Interlock Not Ok	High Voltage Interlock NOK	Key Cycle the unit. (24v disconnect *pause* key switch) If an issue persists contact Viridi Service Department
Max Charge Reached	SBR30 reached Max Cell Voltage for operation	System Stopped Charging
Max Discharge Reached	SBR30 reached Min Cell Voltage for operation	System stopped discharging. Recharge to restore power.
No Grid Power	ON GRID CHARGE not available until voltage present at system and matches transfer switch position	Interruption in Grid Power

Alarm Notification (Text/Email)	HMI Alarm (SBR 30) Touchscreen)	Action
Transfer Switch Moved While Charging	Transfer position switch moved during ON-GRID CHARGE	Set transfer switch to correct position and return unit to proper mode.
Transfer Switch Moved While Discharging	Transfer position switch moved during DISCHARGE	Set transfer switch to correct position and return unit to proper mode.
DC DC Input Under Voltage	High Voltage Input to DCDC Under Voltage.	Unit is in the ON position but does not sense DC Power to re-charge 12v batteries. Key Cycle unit. If the issue still presents contact Viridi Service Department (Candapter may be needed)
DC DC Input Over Voltage	High Voltage Input to DCDC Over Voltage.	Contact Viridi Service Department
DC DC Over Temperature	DCDC Over Temperature.	DC-DC shut down due to high temperature. Cool the unit and wait for temperature to drop. Power off to prevent 1 V battery drain.
DC DC Output Under Voltage	DCDC Output Under Voltage contact customer service	Contact Viridi Service Department
DC DC Output Over Voltage	DCDC Output Over Voltage contact customer service	Contact Viridi Service Department
DC DC Output Short Circuit	DCDC Short Circuit Fault contact customer service	Unit has a potential wiring fault, failed component or a loose cable to the DCDC. Check all connections to the DCDC.
AC Overload Timeout	Sinexcel Inverter AC Overload	Maximum kW exceeded for extended time. Reset unit and review system sizing.
No Voltage	No AC Output Voltage Check breakers	Check the position of the Cam-Lock breaker and ensure the breaker is closed.
AC Over Voltage	Sinexcel Inverter AC Bus Over Voltage	Contact Viridi Service Department
AC Over Frequency	Sinexcel Inverter AC Bus Over Frequency	Contact Viridi Service Department
AC Under Frequency	Sinexcel Inverter AC Bus Under Frequency	Contact Viridi Service Department
AC Phase Reversed	Sinexcel Inverter AC Bus Phase Reversed	Swap blue and red load/grid cam locks.
AC Voltage Asymmetric	Sinexcel Inverter AC Bus Voltage Asymmetric	Contact Viridi Service Department
AC Voltage Abnormal	Sinexcel Inverter AC Bus Voltage Abnormal	Contact Viridi Service Department
AC Phase Lost	Sinexcel Inverter AC Bus Phase Lost	Inspect Cam Lock Connections
Max Cell Voltage For Operation Reached (4.10)	SBR30 reached Max Cell Voltage for operation	System Stopped Charging

Alarm Notification (Text/Email)	HMI Alarm (SBR 30) Touchscreen)	Action
Inverter High Temperature Warning	Inverter Fault Present	Inverter nearing max high temperature. Cool unit and wait for temperature to decrease.
Inverter High Temperature Error	Inverter Fault Present	Inverter shutdown due to high temperature. Cool unit and wait for temperature to decrease. Power unit off to prevent 12v's from dying.
Inverter High Ambient Temperature Warning	Inverter Fault Present	Inverter nearing max high temperature. Cool unit and wait for temperature to decrease.
Inverter High Ambient Temperature Error	Inverter Fault Present	Inverter shutdown due to the high temperature. Cool unit and wait for temperature to decrease. Power unit off to prevent 12v's from dying.
SOC Below 8 Percent	N/A	Battery SOC is below threshold. Verify generator or charging source is operational.
SOC Below 5 Percent	N/A	Battery SOC is below threshold. Verify generator or charging source is operational.
SOC Below 38 Percent	N/A	Battery SOC is below threshold. Verify generator or charging source is operational.
SOC Below 18 Percent	N/A	Battery SOC is below threshold. Verify generator or charging source is operational.
Engine Running - Created	N/A	Notification sent when unit has a Port Forward to the generator and the generator is called ON to support load or charge BESS.
Engine Running - Cleared	N/A	Notification sent when unit has a Port Forward to the generator and the generator is called OFF after supporting load or charging BESS.
Yellow Lamp	N/A	Notification sent when unit has a Port Forward to the generator and the generator has a warning fault present.
Red Lamp	N/A	Notification sent when unit has a Port Forward to the generator and the generator has a critical fault present.
N/A	SBR30 Cell Voltage Differential is True	Warning - Cell imbalance detected. Charge above 50 % SOC and keep unit powered on to enable balancing.
N/A	Sinexcel Inverter AC Bus Under Voltage	Check for tripped breakers behind the cover on the User Interface Panel next to the HMI - Contact Viridi Service Department
ViSTA Lost Connection to the Asset	N/A	Unit is offline or not communicating with ViSTA. Check unit operation, confirm cellular service at the asset location, perform a key cycle, then contact the Viridi Service Department if the issue persists.

## 9.8 Contact Viridi Customer Service

If the issue is unresolved, please contact Viridi Customer Support at 1-866-984-7434

The following information will be requested:

<b>Company Name</b>	
<b>Contact Name and Call Back #:</b>	
<b>Serial Number</b>	
<b>Set Up Details:</b>	
<b>Fault Details, including history relevant to the fault:</b>	

## 10. Appendix

There is a supplemental service manual (9920-00084) that covers the following subjects:

- Microgrid DIES set up and modifications
- Swapping the 12v batteries
- Replacing the Inverter
- 2% SOC recovery
- Trailer installation and removal
- Connection to the VCom via WiFi