



Installation, Operation, & Maintenance Manual



RPSLinkEX 3Φ

(9920-00082)

Energy Storage System for Outdoor Installations

Revision A: Released 13-FEB-2026

Contents

Contents	2
1. Notice	5
2. Safety	7
2.1 Warnings, Cautions, and Important Notes	7
2.2 Battery Precautions	9
2.3 Disposal and Recycling	9
3. Emergency Response Plan	10
4. System Overview	12
4.1 RPSLinkEX 3 Φ Overview	12
4.1.1 RPSLink Configuration Naming Convention	12
4.2 Fail-Safe Anti-Propagation Technology	12
4.3 Physical Parameters	13
4.3.1 RPSLinkEX 3 Φ Dimensions	13
4.3.2 IP Ratings	13
4.4 Performance	14
4.5 RPSLinkEX 3 Φ Components	15
4.5.1 Main Interface of Product (Rear of Device):	15
4.5.2 Inside of User Interface Panel (Front of Device):	16
4.5.3 Interior of Main Cabin of Device:	17
4.6 System Diagram	18
4.7 Example RPSLinkEX 3 Φ 1-line Diagrams	20
4.7.1 Example 1: 150kWh On-Grid BESS	20
4.7.2 Example 2: 150kWh ON / OFF-grid BESS	21
4.7.3 Example 3: 600kWh On / Off-Grid BESS	22
4.8 RPSLinkEX 3 Φ Certifications	22
5. ViSTA Cloud	23
5.1 Logging In	23
5.2 ViSTA Dashboard	24
5.2.1 Fleet View	24

5.2.2	Data Over Time	25
6.	Installation.....	28
6.1	Location Considerations	28
6.2	EMI/EMC Considerations	28
6.2.1	Definitions.....	28
6.3	Handling and Transport.....	29
6.3.1	General Considerations.....	29
6.3.2	Loading and Unloading.....	30
6.4	Wiring Install Instructions.....	31
6.4.1	Sinexcel Intelligent Transfer Switch.....	31
6.5	Commissioning	32
6.5.1	Introduction.....	32
6.5.2	RPSLinkEX 3Φ Commissioning Checklist	32
7.	Startup	35
7.1	RPSLinkEX 3Φ General Startup Instructions.....	35
7.2	RPSLinkEX 3Φ Advanced Settings	38
8	SHUT DOWN.....	40
8.1	RPSLinkEX 3Φ Shutdown Instructions	41
9.	Maintenance	43
9.1	Periodic Scheduled Maintenance	43
9.1.1	Sinexcel Inverter	44
9.1.2	System Enclosure	44
9.1.3	General Electrical and Bolt Interface Connections.....	44
9.1.4	Energy Management System (EMS) Cabinet(s)	44
9.1.5	Torque Check.....	44
9.1.5.1	Torque Check Table	46
9.1.5.2	Torque Reference Images.....	46
9.2	Decommissioning	47
9.3	ViSTA Alarm Definition Glossary.....	48
9.4	ViSTA Alarms	48
9.5	Contact Viridi Customer Service	52

1. Notice

As an express condition of Viridi's warranty and to encourage utilization of industry best practices, Viridi requires that the installation, mobilization, and operation of the RPSLinkEX 3Φ only be completed by, or at the direction of, a qualified professional as defined by the jurisdiction(s) within which the installation, mobilization, and operation occurs. Specific applications can vary, so please direct specific questions to Viridi's attention:

- Telephone: 716-968-8658
- In writing to: sales@viridiparente.com

Viridi expressly disclaims liability for applications made in a manner inconsistent with this guide and/or in non-compliance with local building and electrical codes. This Installation, Operations & Maintenance Manual, incorporates all the terms and conditions of sale. All information provided in this manual is subject to change with or without notice.

Please refer to the warranty documents provided at the point-of-sales for further information.



SAFETY



2. Safety

To make the best and proper use of the RPSLinkEX 3Φ, all personnel handling or operating the RPSLinkEX 3Φ are advised to follow these guidelines:

- Only fully trained and qualified personnel should operate or service the machine. Read and understand the Installation, Operations & Maintenance Manual before operating the equipment to make certain that safe practices are followed, including service and maintenance intervals.
- If there is a defect or evidence of damage that might expose an employee to injury, the defective or damaged RPSLinkEX 3Φ shall be removed from service, and no employee may use it until repairs and tests needed to render the equipment safe have been made.
- Always keep this Installation, Operations & Maintenance Manual in a convenient place for easy access.
- If this Installation, Operations & Maintenance Manual, is lost or damaged, contact Viridi Customer Service, referencing the equipment serial or asset number.
 - **Customer Service: 1-800-984-7434**
 - **Parts Ordering: parts@viridiparente.com**
 - **Service Issues: service@viridiparente.com**
 - **Warranty Claims: warranties@viridiparente.com**
- This Installation, Operations & Maintenance Manual should be considered part of the RPSLinkEX 3Φ and remain with it.
- Constant efforts are made to improve the quality and performance of our products; it may be that some information in the User Manual differs from your equipment. If any questions arise, please contact Viridi Parente, Inc.
- All the information in this publication is based on the latest product information available at the time of printing. Viridi Parente, Inc. reserves the right to make changes to this Installation, Operations & Maintenance Manual, without notice or obligation.
- No part of this publication may be reproduced or copied without prior written permission from Viridi Parente, Inc.

2.1 Warnings, Cautions, and Important Notes



This “Safety Alert” symbol and others like it are in place to warn the operator of potential hazards. It means attention/become alert – the operator’s safety is involved!

This symbol can signify DANGER and, where used, documents a WARNING or CAUTION which is followed by text highlighting the potential hazard. This manual will detail the potential hazards so that necessary precaution(s) towards ensuring operator and equipment safety.

A WARNING signifies a situation whereby the operator, members of staff, or the public could be put in danger of personal injury by the improper operation of the RPSLinkEX 3Φ.

A CAUTION signifies a situation whereby damage to the RPSLinkEX 3Φ or associated parts could be caused by improper operation of the RPSLinkEX 3Φ.

Symbols Used in This Manual

	Warning/Cautions		Wear Gloves
	Shock Hazard		Quality
	General Safety		Tip

General Precautions



COMPETENT PERSONNEL: The RPSLinkEX 3Φ is intended for use by suitable qualified, trained, and competent personnel who have read and understand this manual and are familiar with the equipment and its intended use. A certain level of user competence is assumed when operating power generating equipment.



READ AND UNDERSTAND: Before personnel operate, service, or perform tasks on the equipment, the manual must be read and understood.



VENTILATION: Do not obstruct the air vents and allow adequate space around the RPSLinkEX 3Φ for ventilation.



ELECTRICAL SAFETY: Follow all applicable electrical codes and standards. Ensure proper grounding and bonding of the system components. Use appropriate PPE, including high voltage gloves, safety glasses, protective clothing, and insulated tools when working on electrical connections.



PRECAUTIONS: Follow the precautions listed within this manual before operation and during operation, service, and maintenance activities for the safety of the operator and others and to protect the performance of the equipment.



WARNING LABELS: Keep warning and caution labels from becoming dirty or torn and replace them if they become damaged. Replacements can be obtained by contacting Viridi Parente, Inc.



SAFETY: Safety is an utmost concern. Safety statements are one of the primary ways to call attention to potential hazards associated with generator operations.



FIRE SAFETY: Install fire suppression systems as required by local codes and regulations. Ensure that fire extinguishers and other firefighting equipment are readily accessible and properly maintained.



EMERGENCY PROCEDURES: Establish and communicate emergency procedures, including shutdown protocols, evacuation routes, and first responder action plans. Ensure all personnel are trained in these procedures.

Warnings



CRUSH HAZARD: The RPSLinkEX 3Φ is a crush hazard when elevated above ground level, and the area below the RPSLinkEX 3Φ should be cleared before hoisting the RPSLinkEX 3Φ above ground level.



DANGER OF FALLING: Do not stand on top of the RPSLinkEX 3Φ. The surface may be slippery.



SHOCK HAZARD: Authorized access only. Do not remove panels to access internal components of the RPSLinkEX. There are no user-serviceable parts inside the RPSLinkEX 3Φ. Only qualified, competent personnel are permitted to service internal components. Unauthorized Persons attempting to do so will be at risk of electric shock.



SITE ACCESS: Restrict access to the installation site to authorized personnel only. Implement security measures such as fencing, surveillance, and access control systems to prevent unauthorized entry



HIGH VOLTAGE: The battery energy storage system contains high voltage components. Always de-energize the system before performing any maintenance or repairs. Use lockout/tagout procedures to ensure the system remains de-energized during work.



THERMAL RUNAWAY: Be aware of the risks associated with thermal runaway in lithium-ion batteries. Implement measures to detect and mitigate thermal runaway events, such as temperature monitoring and automatic shutdown systems.



CHEMICAL HAZARDS: Batteries contain hazardous chemicals that can pose health risks if released. In the event of a battery leak or spill, follow appropriate hazardous material handling procedures and use spill containment equipment.



MECHANICAL HAZARDS: Use proper lifting techniques and equipment when handling heavy battery packs. Ensure that battery packs are securely mounted and supported to prevent tipping or falling.

2.2 Battery Precautions

The chemicals and materials in the battery are stored in a sealed container, designed to withstand temperatures and pressures encountered during normal use. As a result, during normal use, there is no physical danger of ignition, explosion, or hazardous material leakage. There is only a risk of exposure if a battery is mechanically, thermally, or electrically abused. There is no user access to the batteries. Do not remove panels. For the RPSLinkEX 3Φ to operate at an optimal capacity they should be stored in a cool, dry place away from direct sunlight and sources of heat.

2.3 Disposal and Recycling

The RPSLinkEX 3Φ comprises components that must be disposed of responsibly. Many of the components can be reused or recycled. For advice on the safe and proper disposal of RPSLinkEX 3Φ, please contact the Viridi sales representative. Viridi Parente, Inc. partners with American Battery Technology Company to disassemble end of life battery cells into critical minerals to be reused.

3. Emergency Response Plan

The RPSLinkEX 3Φ includes internal fault mechanisms designed to prevent failures and subsequent risk hazards. However, Viridi cannot guarantee safety performance of the RPSLinkEX 3Φ if the equipment is exposed to abuse, damage, or negligence.

If an installer or user happens to be exposed to the internal materials of the battery cell due to damage on the outer casing, the following actions are recommended:

- **In Case of Inhalation:** Leave the contaminated area immediately and seek medical attention.
- **In Case of Skin Contact:** Wash the contacted area thoroughly with soap and seek medical attention.
- **In Case of Ingestion:** Induce vomiting and seek medical attention.

If a fire breaks out at or near the location of the RPSLinkEX 3Φ, perform the following counter measures:

- In the event of a fire, appropriate extinguishing media should be used based on the type of incident. For battery-related fires, the system should be allowed to burn itself out while defensive firefighting strategies are employed to protect nearby exposures, if necessary. For non-battery-related fires, such as those occurring near an RPSLinkEX 3Φ unit, suitable extinguishing agents, including water or an ABC fire extinguisher, should be utilized. Additionally, if a fire occurs adjacent to the RPSLinkEX, water may be applied as a defensive measure to cool the unit, if deemed necessary.
- Follow the proper fire-fighting instructions. If a fire occurs when charging the RPSLinkEX3 P, provided it is safe to do so, disconnect the battery pack circuit breaker to shut off the power charge. If the battery pack is not on fire yet, extinguish the fire before the battery pack catches fire, preferably with water. If the battery pack within the RPSLinkEX 3Φ is on fire, do not try to extinguish it, and evacuate people from the premises immediately.
- **WARNING:** Explosion is possible if the battery pack within the RPSLinkEX 3Φ experiences temperatures above 150°C (302°F). When a battery pack is burning, it will leak poisonous gases. Do not approach it.
- To deal with an accident with the RPSLinkEX 3Φ on land, refer to the site-specific emergency response plan, if available and move the damaged RPSLinkEX 3Φ to a segregated location and call your local fire department or service engineer. Service inspection must be completed by Viridi or an authorized service center before the unit can be cleared for operation.
- Note that proper lockout/tagout procedures must be followed in such cases. To deal with an accident with the RPSLinkEX 3Φ in the water, stay out of the water and do not touch anything if any part of the battery, inverter, or wiring is submerged. Do not use the submerged battery again.
 - Contact your Viridi Service Team for assistance at:
 - **Customer Support Line: 1-866-984-7434**
 - **Email: service@viridiparente.com**

SYSTEM OVERVIEW



4. System Overview

Disclaimer: The images contained within this section and the ensuing sections may not be directly reflective of a complete installation. Custom installation solutions are possible depending on space constraints of the installation location.

4.1 RPSLinkEX 3Φ Overview

The RPSLinkEX 3Φ is a modular Lithium-Ion Battery Energy Storage System for outdoor installation in residential, commercial and industrial zones. It is designed to scale in increments of roughly 50kWh to fit the energy requirements of nearly any application. It consists of two major components:

rps50 Battery Pack – the 50kWh building block allowing a system to be designed from 50kWh to multiple Megawatt hours

Main Enclosure – containing the full componentry of the system, including the rps50 battery pack.

4.1.1 RPSLink Configuration Naming Convention

RPSLinkEX 3Φ-480V-3Φ-150kWh-30kW

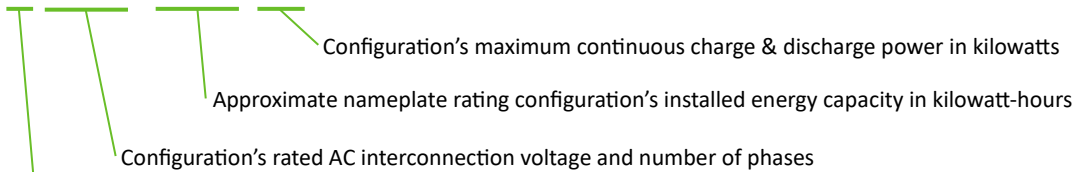

EX: BESS equipment is skid mounted within a NEMA rated enclosure for outdoor installations on a concrete pad
IN: BESS equipment components are individually skid mounted for indoor installations

4.2 Fail-Safe Anti-Propagation Technology

Viridi's core value proposition lies in the Fail-Safe Anti-Propagation architecture built into RPS50 battery packs, each of which contains 48.9kWh of nameplate energy storage. UL9540A testing, which involves intentionally heating a cell within the pack to the point of thermal failure, demonstrated that Viridi's passive technology halts cell-to-cell thermal propagation with no detectable release of heat, sparks, smoke, or flames. The pack enclosure is built from ¼" steel and IP55 rated for an extremely durable industrial design built to survive harsh environments. This technology makes Viridi's BESS uniquely suitable for safe deployments in and around occupied spaces and critical equipment.



4.3 Physical Parameters

RPSLinkEX 3Φ is a fully contained outdoor system.

4.3.1 RPSLinkEX 3Φ Dimensions

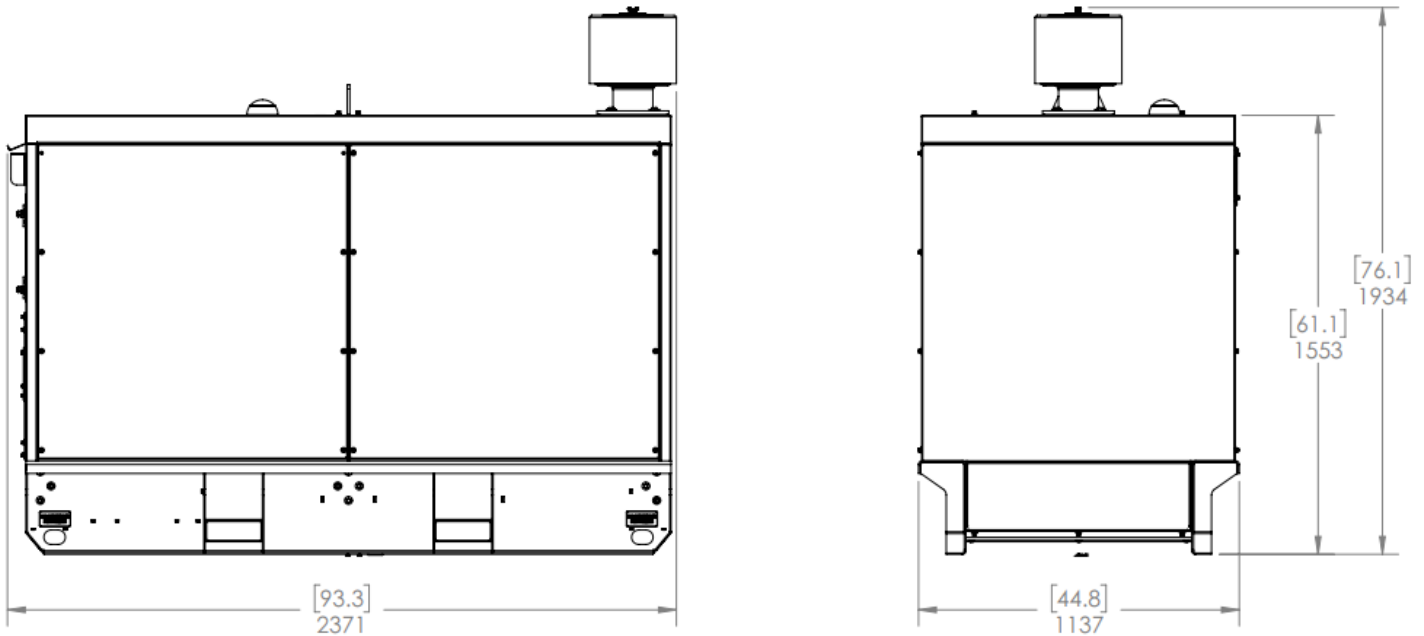

4.3.2 IP Ratings

RPS50 battery pack carries an IP55 rating

The RPSLinkEX 3Φ enclosure passes a NEMA 3R weatherproof test.

4.4 Performance

Model	480V-3Φ-150kWh-30kW	480V-3Φ-100kWh-20kW	208V-3Φ-150kWh-30kW	208V-3Φ-100kWh-15kW	208V-3Φ-50kWh-10kW
System Contains	(1) Sinexcel 3Φ Inverter.	(1) Sinexcel 3Φ Inverter	(1) Sinexcel 3Φ Inverter <u>(1) 30kVA Transformer</u>	(1) Sinexcel 3Φ Inverter	(1) Sinexcel 3Φ Inverter
	(3) RPS50 Packs	(2) RPS50 Packs	(3) RPS50 Packs	(2) RPS50 Packs	(1) RPS50 Pack
Nameplate Capacity (kWh)	146.7	97.8	146.7	97.8	48.9
Usable Capacity (kWh)	130.2	86.8	130.2	86.8	43.4
Max Continuous Power, Charge/Discharge (kW)	30	20	30	15	10
Operating Voltage	480V	480V	208V	208V	208V
Max Continuous Current, Charging/Discharging (A)	36.1	24.1	83.3	41.6	27.8
Onboard Inverters	(1) Sinexcel PWS2-30P-NA				
PWS2-30P-NA Fault Current Contribution [AC side short circuit current on-grid] (A)	130A / 100 MS	130A / 100 MS	130A / 100 MS	130A / 100 MS	130A / 100 MS
Maximum Overcurrent Protection Device Rating (A)	60A	60A	125A	60A	50A
Allowed Conductor Type & Size Range	Cu/Al	Cu/Al	Cu/Al	Cu/Al	Cu/Al
	2-8 AWG	2-8 AWG	2-8 AWG	2-8 AWG	2-8 AWG
	Cu/Al (Str)	Cu/Al (Str)	Cu/Al (Str)	Cu/Al (Str)	Cu/Al (Str)
	2/0 -1 AWG	2/0 -1 AWG	2/0 -1 AWG	2/0 -1 AWG	2/0 -1 AWG
Recommended Conductor Sizing	6 AWG	6AWG	2AWG	6 AWG	6 AWG
Grounding Requirements	Grounding of the system and related components must comply with the applicable local electrical code of the installation.				
Operating Temp. Range	14°F ~ 113°F -10°C ~ 45°C				
Battery Pack Primary Lifecycle	4,000 cycles				
Communication / Telematics	Viridi VCOM Device				

4.5 RPSLinkEX 3Φ Components

4.5.1 Main Interface of Product (Rear of Device):

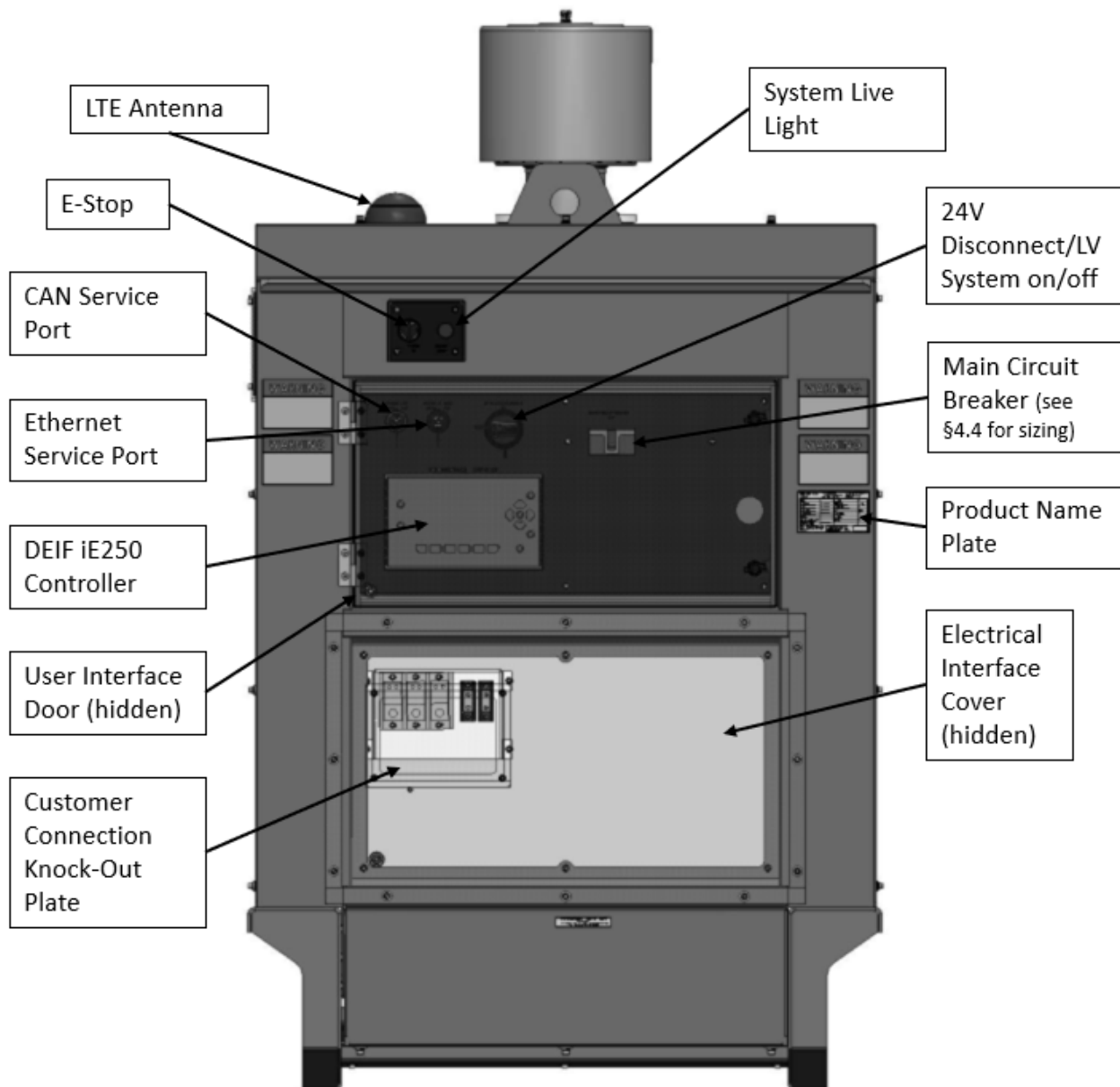

4.5.2 Inside of User Interface Panel (Front of Device):

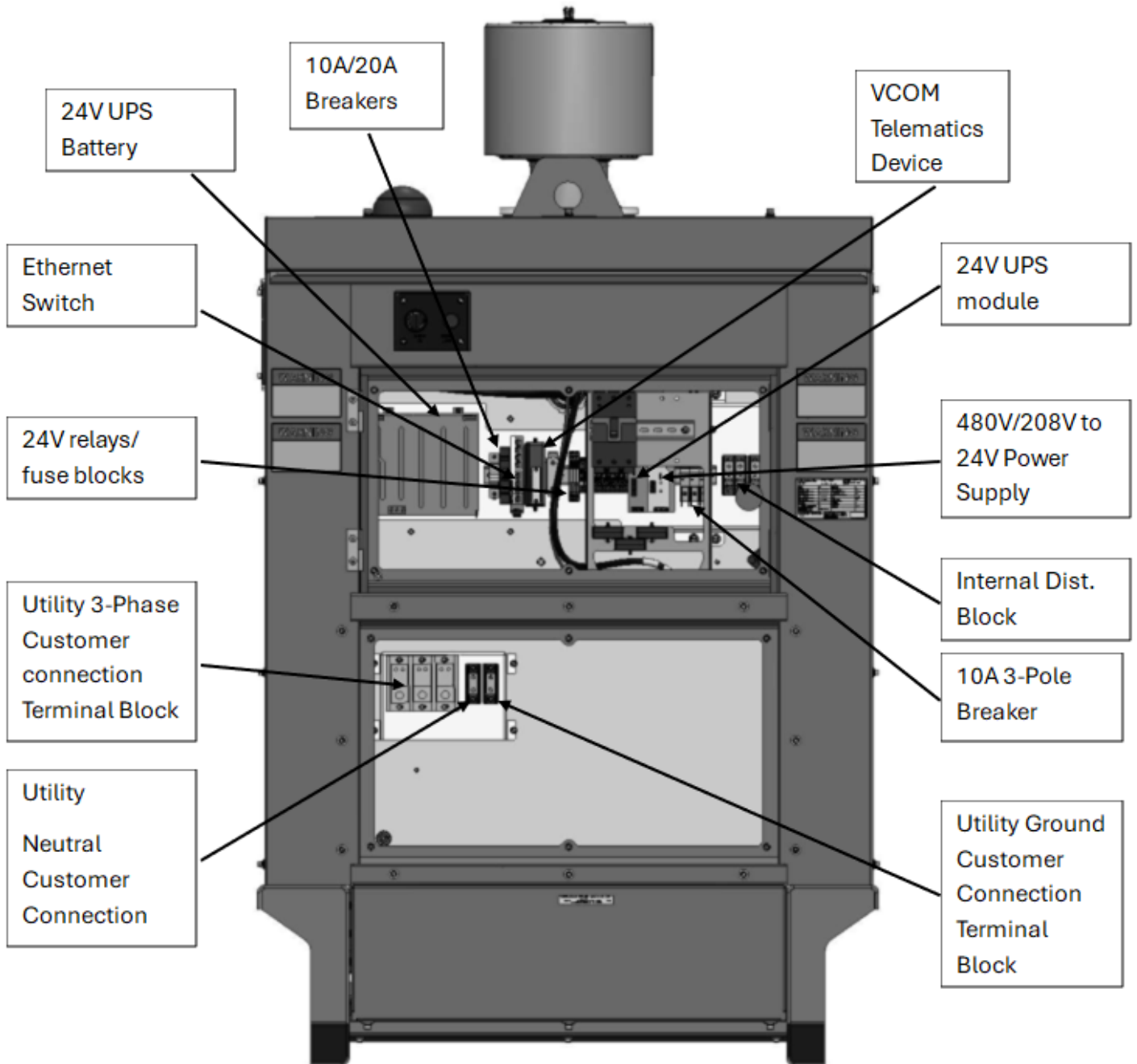

4.5.3 Interior of Main Cabin of Device:

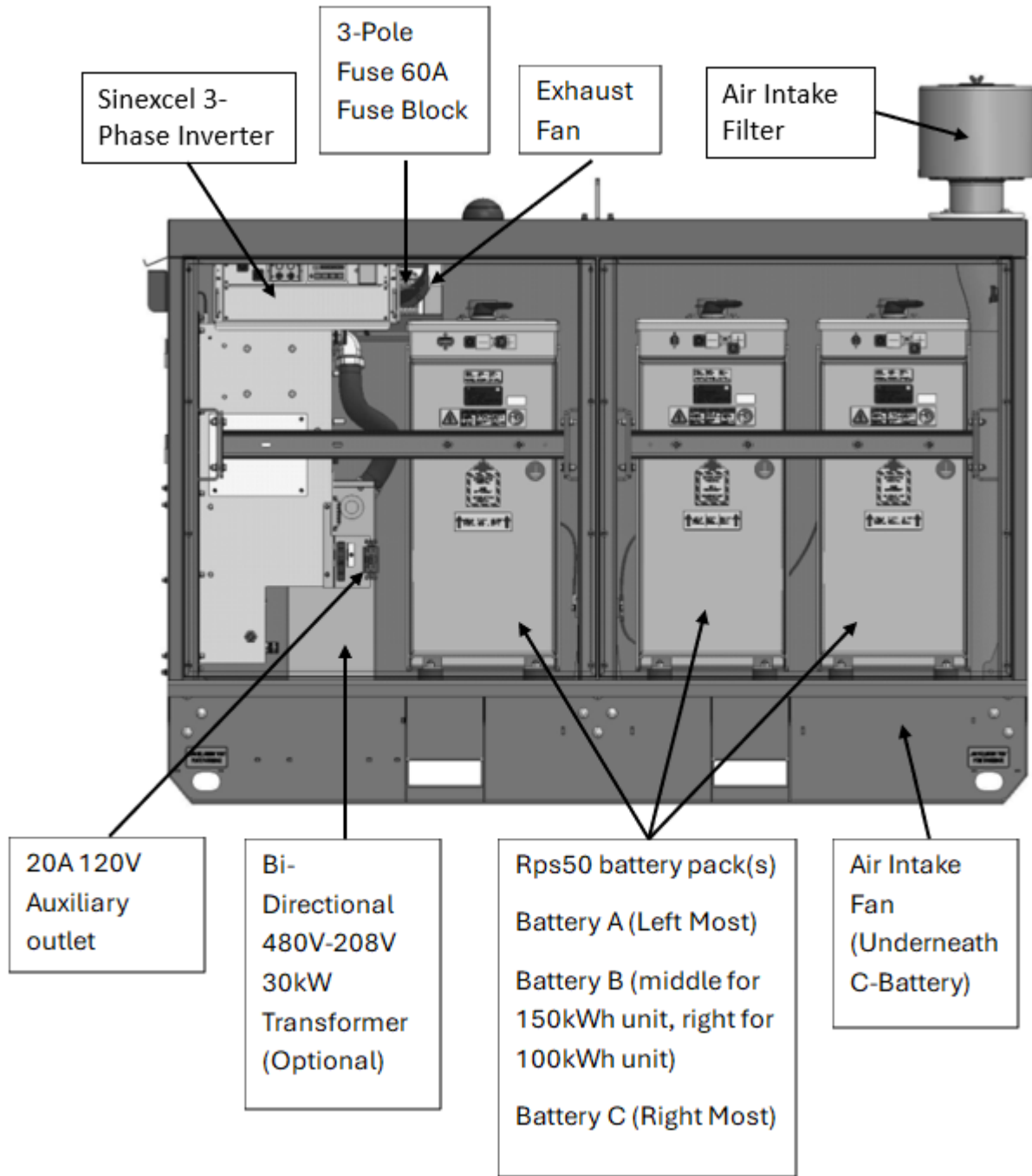

4.6 System Diagram

Note: Below is the System Diagram for the 208V-3Φ-150kWh-30kW version of the RPSLinkEX 3Φ. If another version is needed, it is available via request to Viridi.

The figure below identifies the RPSLinkEX3Φ -208V-3Φ-150kWh-30kW System Diagram

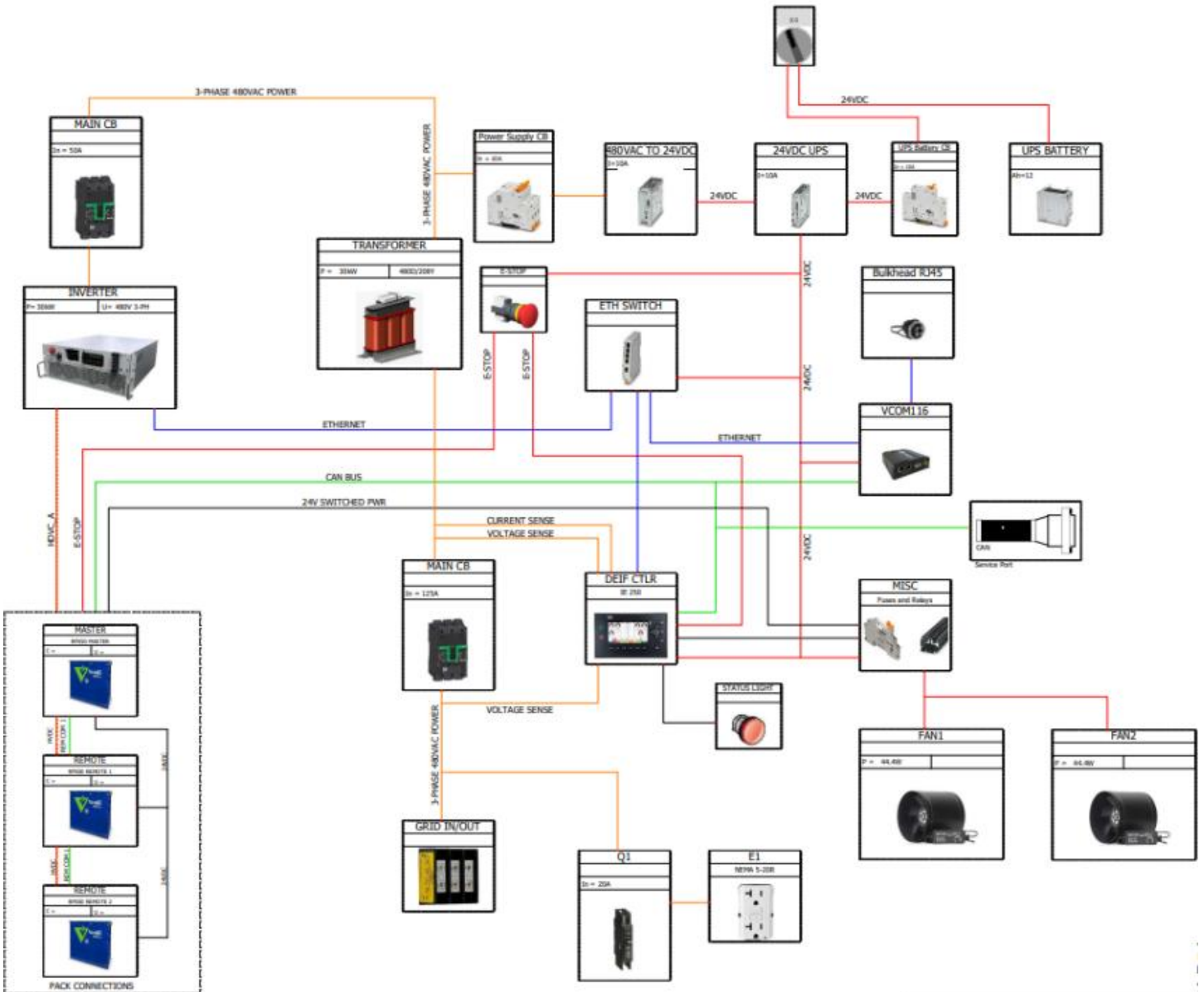

The figure below identifies the RPSLinkEX 3Φ -480V-3Φ-100kWh-20kW System Diagram

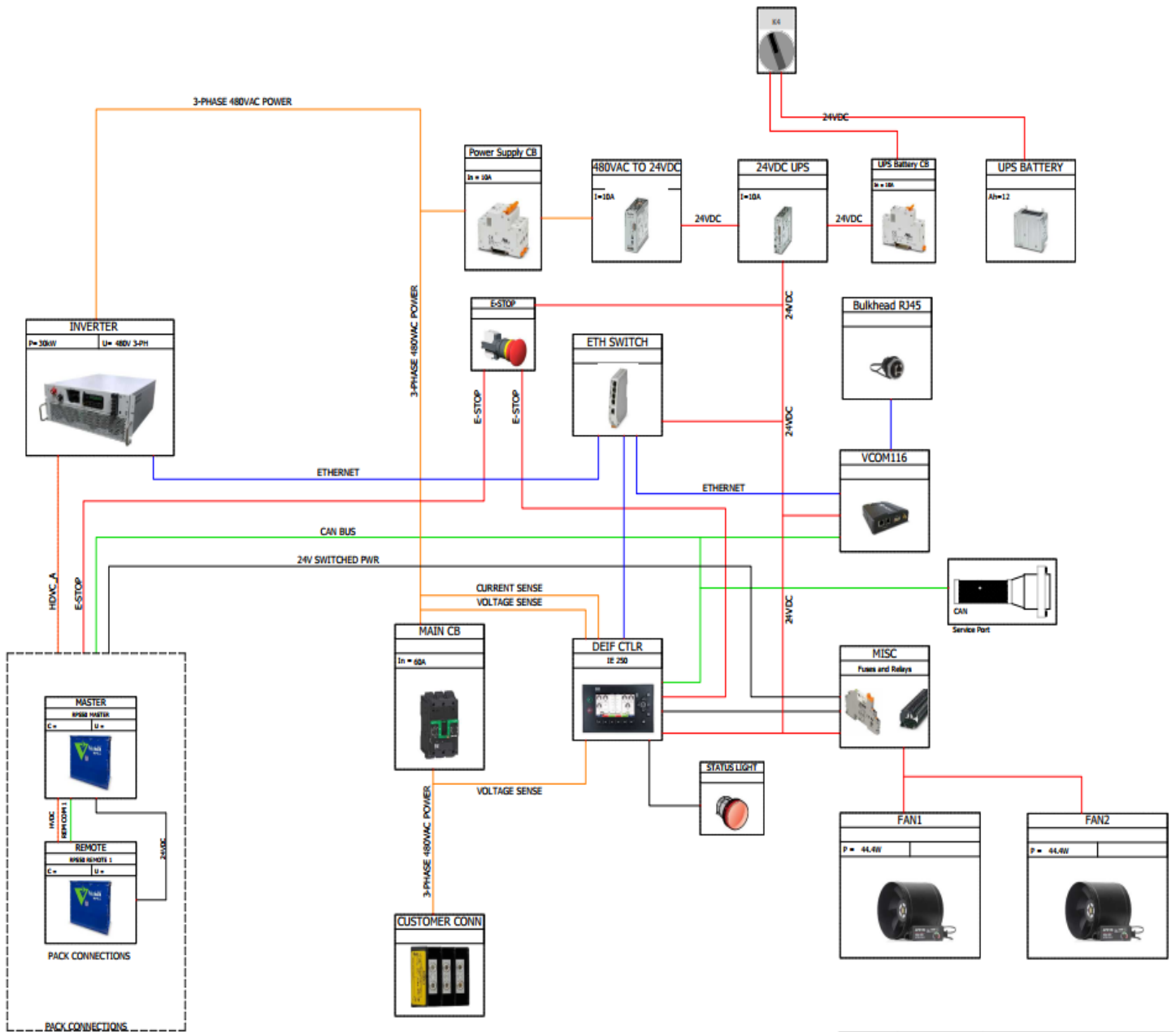

4.7 Example RPSLinkEX 3Φ 1-line Diagrams

RPSLinkEX 3Φ is a modular system that can be designed into many configurations – the following 1-line diagrams represent a few typical arrangements but are by no means representative of every system. Please contact Viridi's Technical Sales Department at 716-968-8658 for configuration assistance.

4.7.1 Example 1: 150kWh On-Grid BESS

[Behind The Meter] 208VAC 3Φ Solar PV + RPSLinkEX 3Φ-208V-3Φ-150kWh-30kW

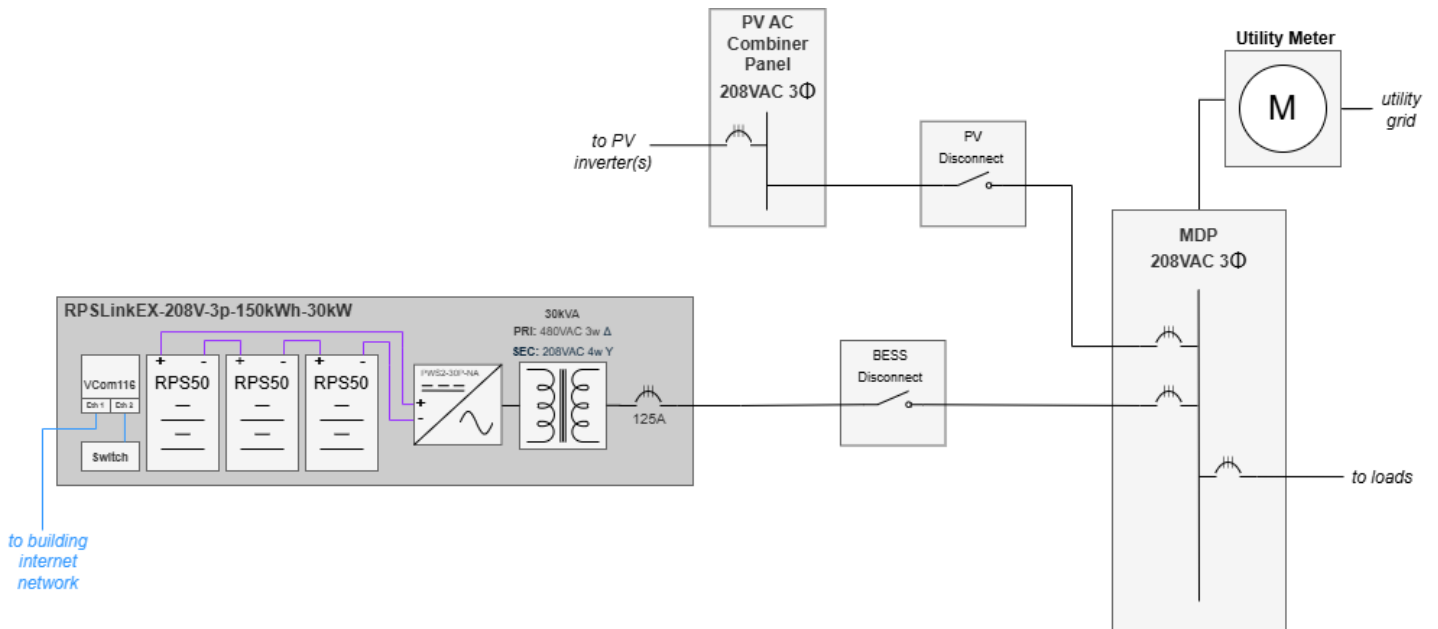

4.7.2 Example 2: 150kWh ON / OFF-grid BESS

[Behind The Meter] 480VAC 3Φ Solar PV + RPSLinkEX 3Φ-480V-3Φ-150kWh-30kW + PWD-100M (for off-grid backup) + EMS

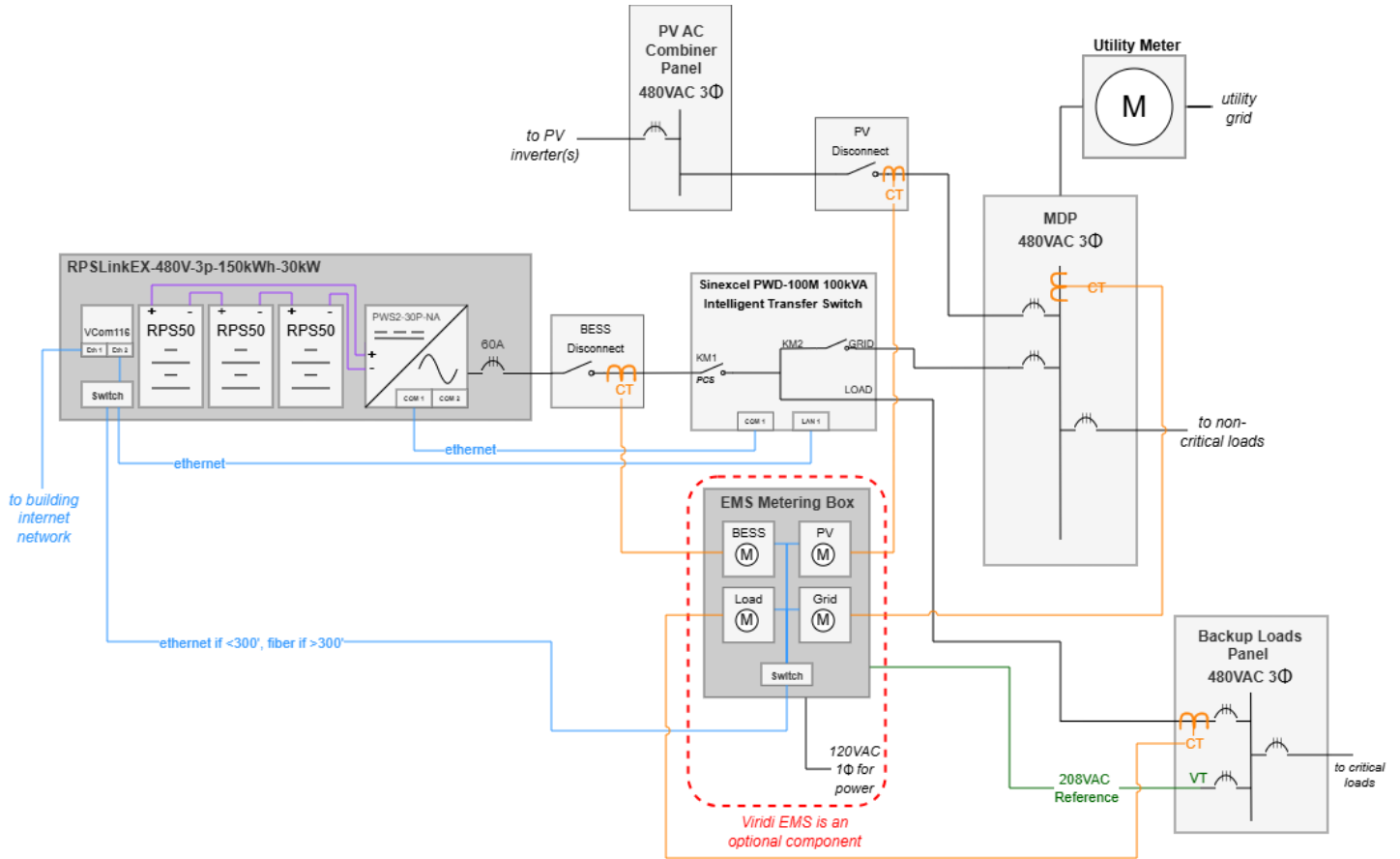

4.7.3 Example 3: 600kWh On / Off-Grid BESS

[Behind The Meter] 480VAC 3Φ Solar PV + (4) RPSLinkEX 3Φ-480V-3Φ-150kWh-30kW + PWD-100M (for off-grid backup) + EMS

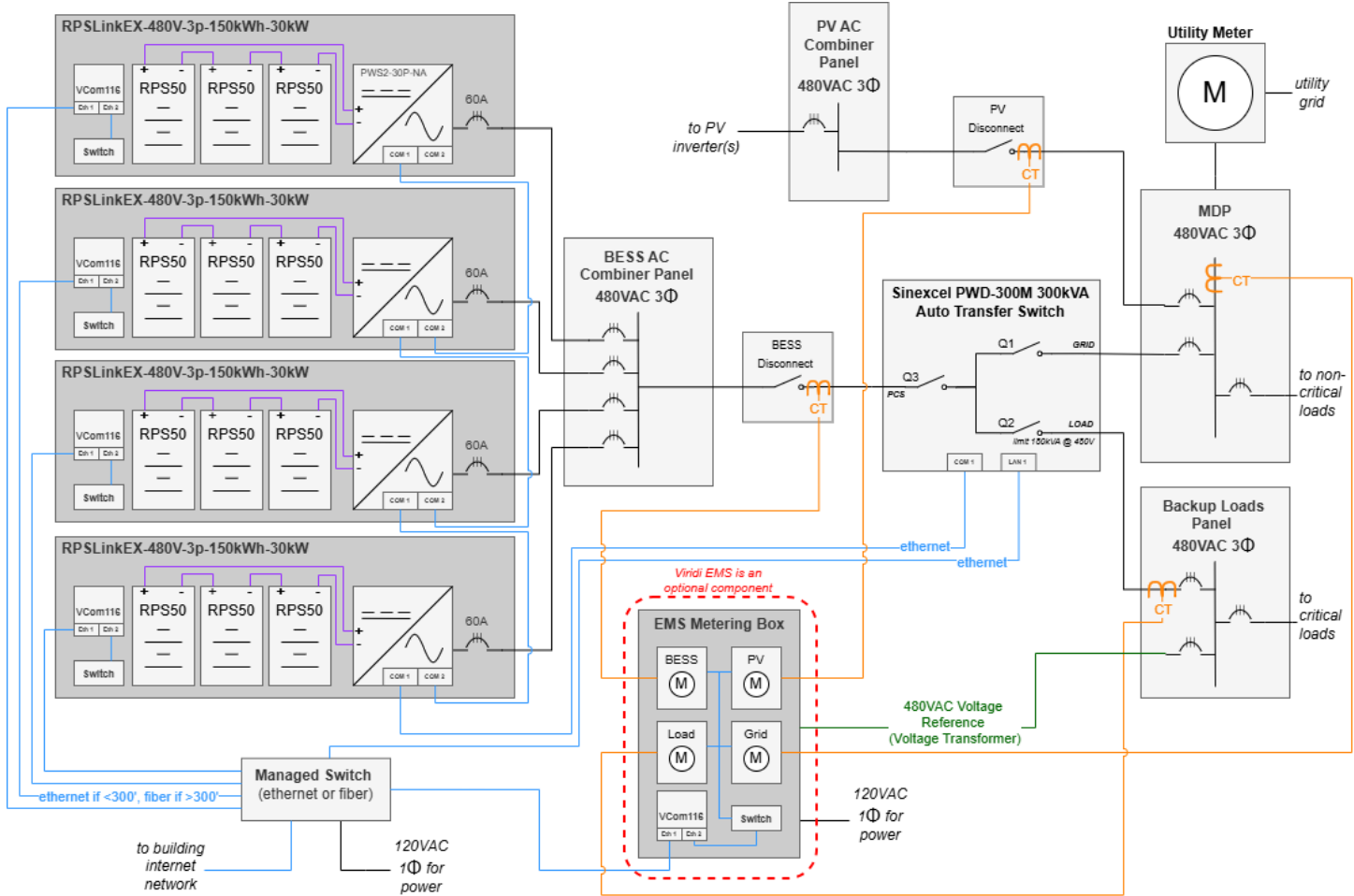

4.8 RPSLinkEX 3Φ Certifications

- UN 38.3 (cell, module)
- UL 1642 (cell) UL Recognized Component
- UL 1741 (Sinexcel PWS2-30P-NA inverter) cTÜV SÜDus Listed
- UL 1741 (Sinexcel PWD-100M ATS Module) cETLus Listed (optional)
- IEEE 1547 (inverter) cTÜV SÜDus Listed
- UL 1973 (pack) cTÜVusListed
- UL 2580 (cell) UL Recognized Component
- UL 9540A (cell/module/pack tested)

5. ViSTA Cloud

RPSLink utilizes a wireless cellular communications module to send location and usage metrics to an administrative dashboard called ViSTA Cloud. The following will provide the basics for utilizing ViSTA.

5.1 Logging In

Request a ViSTA Cloud account by emailing service@viridiparente.com. An email will be sent from vista.notifications@viridiparente.com with a link to setup the account. Once setup, login by going to <https://vista.viridiparente.com/login>.

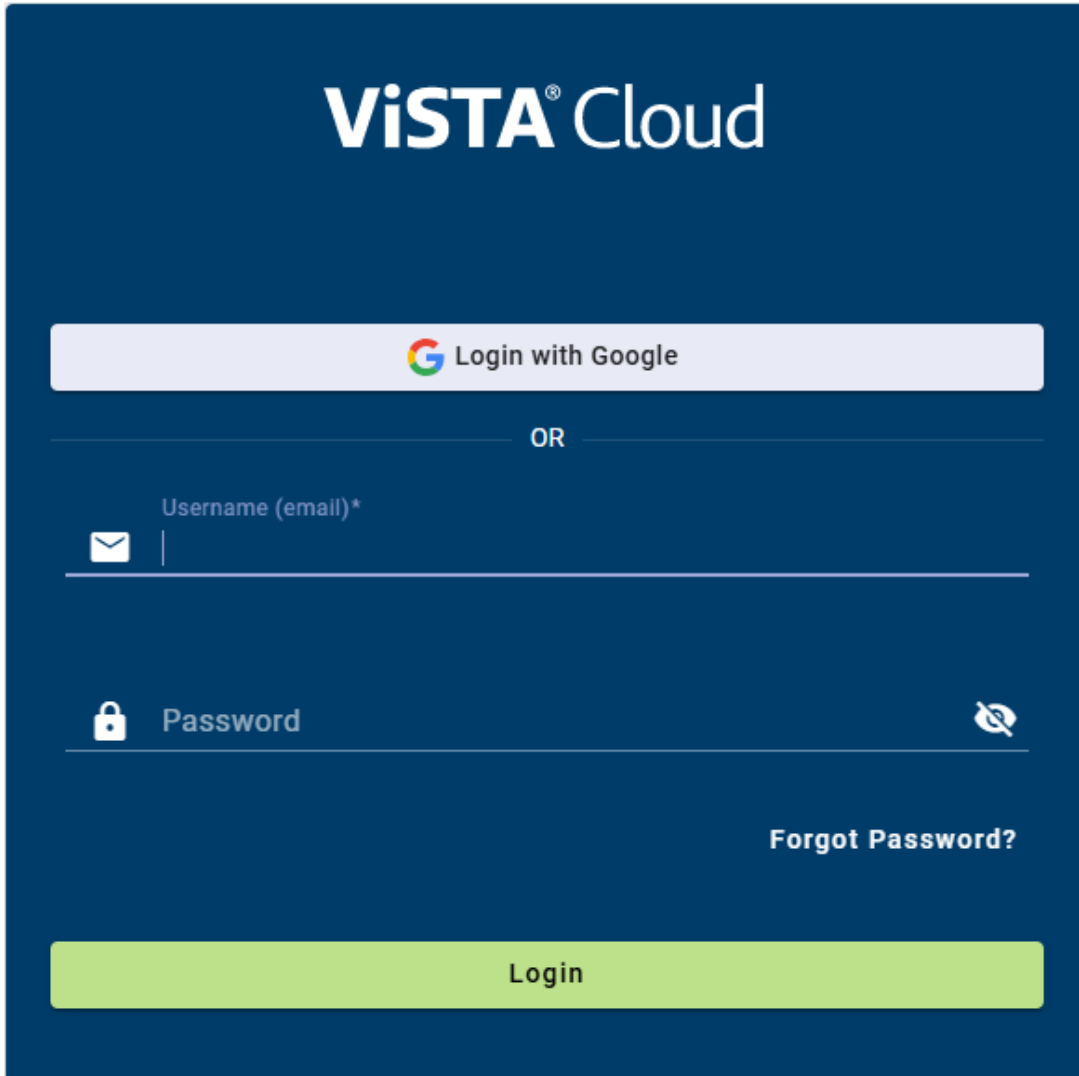

ViSTA® Cloud

Login with Google

OR

Username (email)*

Password

[Forgot Password?](#)

Login

5.2 ViSTA Dashboard

5.2.1 Fleet View

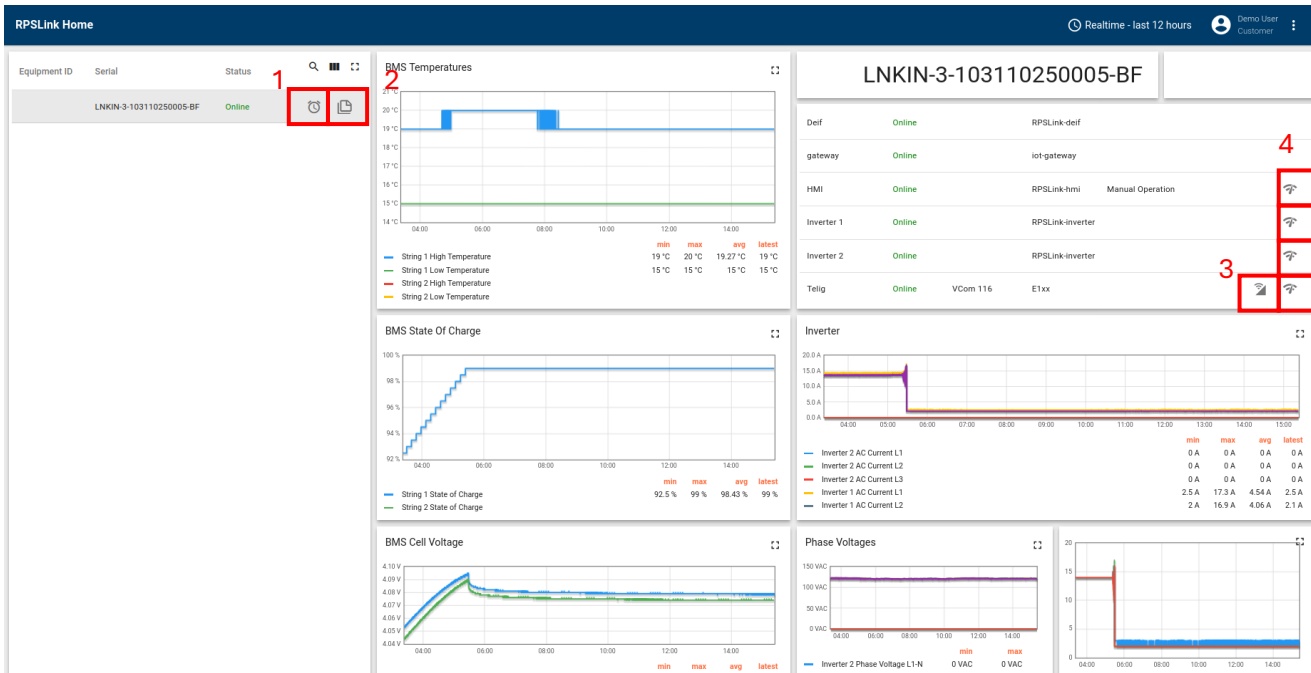

1. **Alarms:** This button opens a modal for viewing alarms, which can be filtered to show any alarms notifications status and severity.
2. **Notes:** This button allows the user to update notes for the unit.
3. **Connectivity:** This allows you to view the connectivity statistics of the unit.
4. **Ping Sensor:** this allows you to ping the VCom and sensors to test connectivity.

5.2.2 Data Over Time

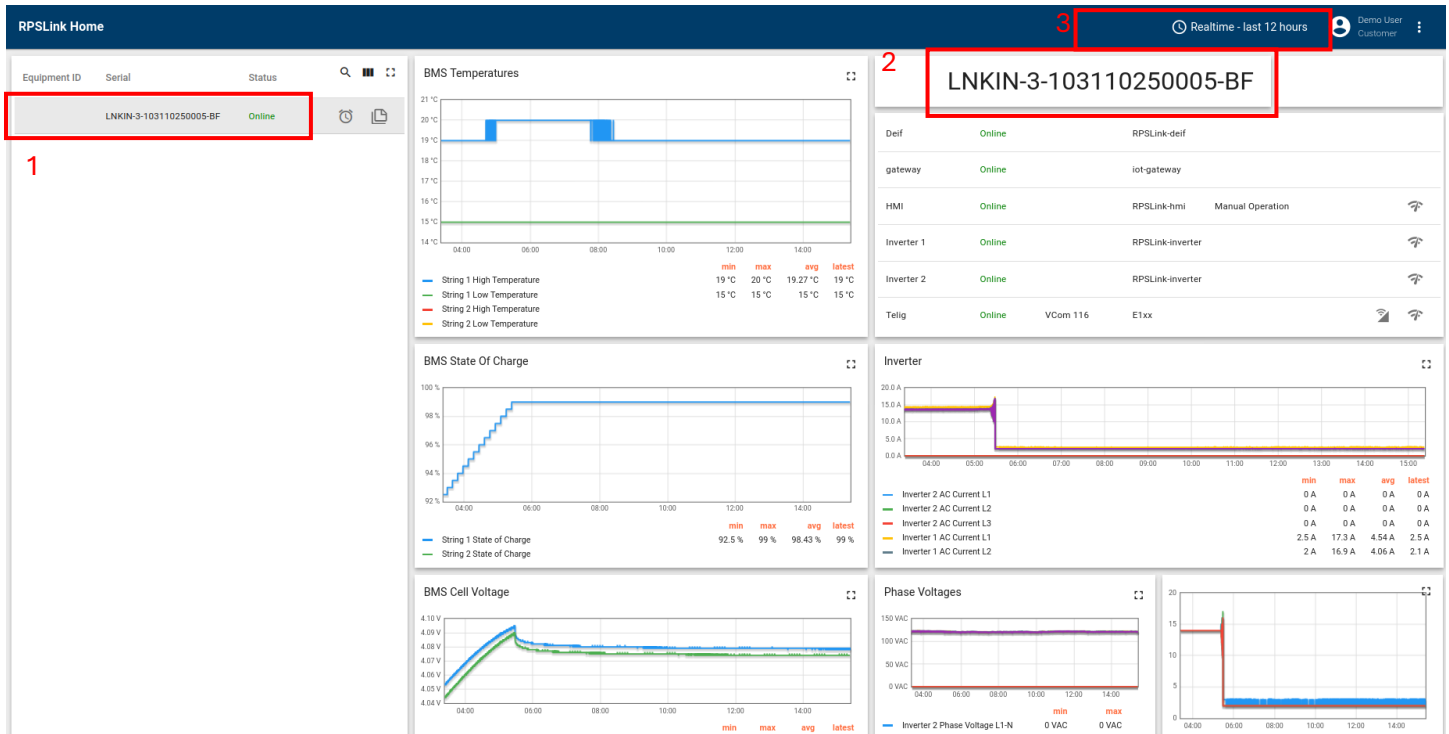

1. **Select Unit:** By Clicking on the row, you will select a unit.
2. **Selected Unit:** This tells you which unit is currently selected.
3. **Time Window:** This allows you to modify the time window.
 - a. It is recommended when working with a time window larger than 1-day you set the aggregation method to "Average".

The alarms area permits viewing of active alarms, the type of alarm, the severity, and the status of the alarm on RPSLink.

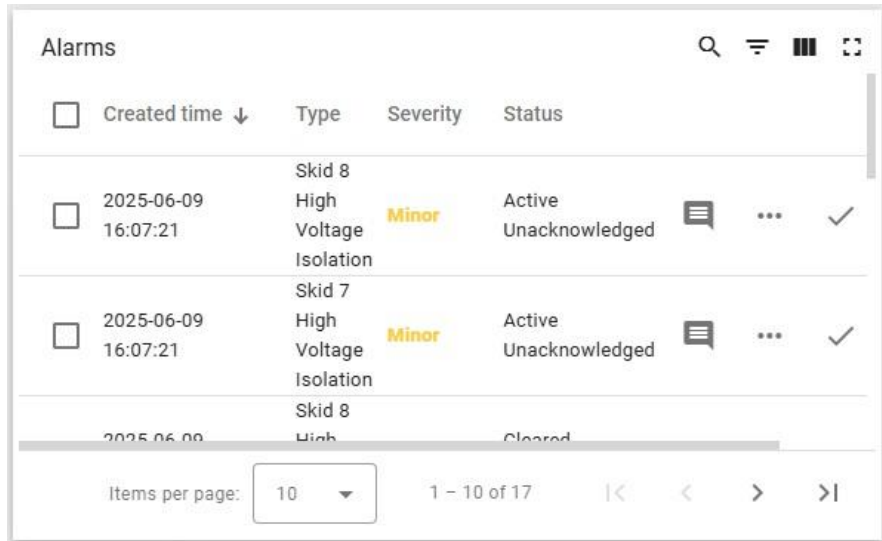

Clicking on the box to the left of the alarm will acknowledge and/or clear the alarm.

Note: The alarm is only cleared on ViSTA, not on the RPSLink

Clicking on the word bubble icon on the right will allow a screen view to see the activity of the RPSLink add comments concerning the alarm.

By clicking the clock icon in the upper right-hand corner of any of the diagram or system devices screens will open a menu will allow viewing the real time activity or history of the system.

The real time tab allows you to choose a period to view from the current time to however long ago it is set for.

The History tab is the same as the real-time tab except for the ability to choose a period in the past to view instead of just allowing a view of what the system is doing for an ongoing time frame. For example, the election can permit a view: a day from three weeks ago instead of the past 24 hours.

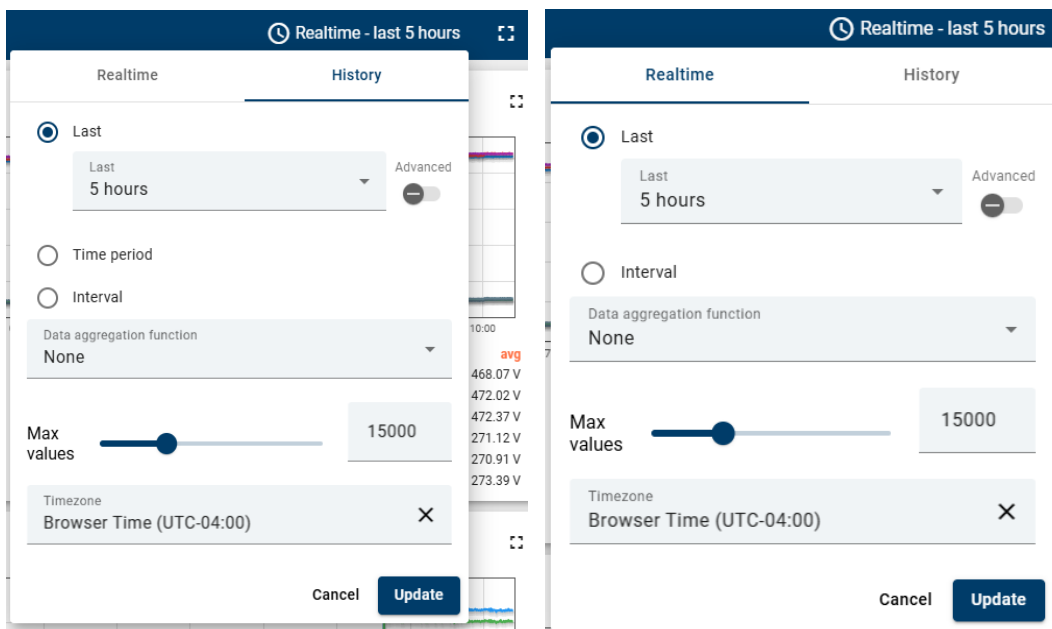

INSTALLATION



6. Installation

6.1 Location Considerations

Determine the necessary size of energy storage/back-up system for your specific application. Different project sites require different kWh of energy storage.



Submit designs and plans to appropriate authorities for review. Before beginning installation or utilization, permits and inspections must be obtained in accordance with local laws and regulations, as necessary



Coordinate site delivery and installation. RPSLinkEX 3Φ components are heavy and must be installed with proper equipment. RPSLinkEX 3Φ must be installed according to the design plans above.

To decommission or uninstall the RPSLinkEX 3Φ, contact your Viridi service team for further instructions. This must be completed by Qualified Personnel, and any disposal of components requires compliance with local laws, rules, and regulations. Viridi encourages recycling of all materials where possible and works with American Battery Technology Company to recover lithium-ion battery components

Required equipment, tools, and other items depend on the final consumer and installation location. Consult your service engineer and local installer for further instruction.

6.2 EMI/EMC Considerations











6.2.1 Definitions

Electromagnetic interference (EMI) and electromagnetic compatibility (EMC) are both important considerations when working with electronic components. EMI is caused by electromagnetic emissions that can disrupt the function of electronic devices and radio frequency (RF) systems. These devices and systems must be properly shielded from electromagnetic radiation for them to work well. EMC measures how well these devices and systems can work in the presence of disruptive electromagnetic interference. Additionally:

- The inverter UL lists safety standards for the Inverter 1741 Supplement B and the Battery is UL1973 listed.
- The inverter and battery undergo EMI/EMC testing.
- The BESS undergoes ground bond testing to verify low chassis/earth impedance on the ground lug in the EBox.
- Within RPSLinkEX 3Φ, all communication wiring if run near high voltage AC/DC wiring is shielded to reduce the potential effect. Otherwise, it is run in separate locations to remove the EMC/EMI potential on the communication lines.

6.3 Handling and Transport

6.3.1 General Considerations

	Do not expose RPSLinkEX 3Φ components to an open flame.
	Do not place or store RPSLinkEX 3Φ components near highly flammable materials.
	Do not expose or place RPSLinkEX 3Φ components near water sources.
	Do not install RPSLinkEX 3Φ components in an airtight enclosure or in an area without ventilation.
	Store RPSLinkEX 3Φ components on a flat, level surface in a cool, dry location.
	Do not disconnect, disassemble, or repair RPSLinkEX 3Φ components with unqualified personnel. Only Qualified Personnel should handle, install, and service the RPSLinkEX 3Φ components.
	Do not deform, impact, cut, or penetrate the RPSLinkEX 3Φ components with a sharp object. Doing so may cause a fire or leakage of electrolytes.
	Do not step on or stand on RPSLinkEX 3Φ components or their packaging.
	Do not place any objects on top of RPSLinkEX 3Φ components.
	Do not charge or discharge RPSLinkEX 3Φ if damaged or malfunctioning.

Note: Lifting and unpacking guidelines will depend on the final consumer and local installation parameters. Follow established workplace safety guidelines and procedures when receiving, handling, transporting, unpacking, lifting, and installing RPSLinkEX 3Φ Components.

6.3.2 Loading and Unloading

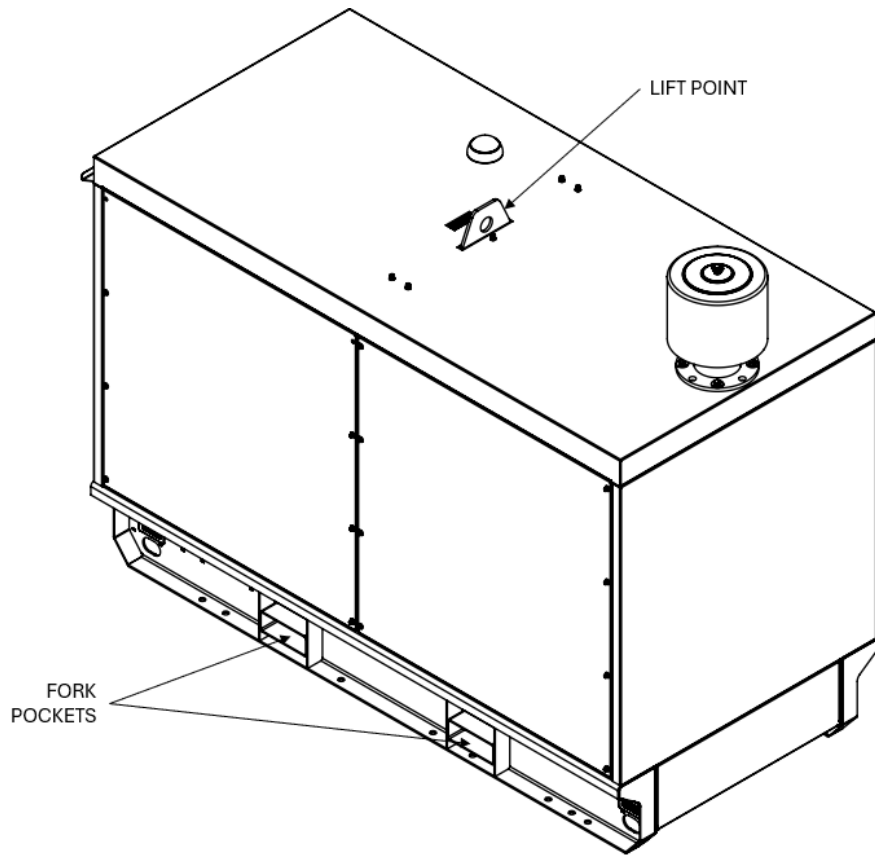

Unit Weight is 5,500lbs / 2,500Kg

6.4 Wiring Install Instructions

Step 1 — Run and Land utility connection AC wiring

- Run Utility connection wiring into the bottom panel on the RH side when facing the control panel
- Land the 3-phase wire connections to the bottom of the 3-phase terminal block
- Land the Ground wire to the 1-Phase terminal block

Note: Please reference 9.1.5.1 for the torque specification during install

Step 2 — Run Ethernet (CAT 5E or 6 - RJ45) communication wires to RPSLinkEX 3Φ

- Run ethernet cables from the building to the RPSLinkEX 3Φ
- Route the ethernet cables inside the lower panel to the bulkhead connectors or to the units unmanaged switch- any open port.

6.4.1 Sinexcel Intelligent Transfer Switch

The Sinexcel PWD-100M / PWD-300M Intelligent Transfer Switch are optional components required for RPSLinkEX 3Φ to provide automatic backup during a loss of grid power. They are not considered part of the RPSLinkEX 3Φ system but can be connected to the customers installation of the RPSLinkEX 3Φ to provide automatic backup functionality.

Utility and Load connections w/ Intelligent Transfer Switch

- Drop Utility connection wiring into housing for Intelligent transfer switch and land on the “GRID” Connection
- Drop Load connection wiring into housing for Intelligent transfer switch and land on the “LOAD” Connection
- Drop PCS connection wiring into housing for Intelligent transfer switch from the PCS Cabinet and land on the “PCS” Connection

6.5 Commissioning

6.5.1 Introduction

Commissioning of a newly installed and existing ESS that has been retrofitted, replaced or previously decommissioned and is returned to service shall be conducted prior to the ESS being placed in service in accordance with a commissioning plan that has been approved prior to initiating commissioning.

6.5.2 RPSLinkEX 3Φ Commissioning Checklist

Commissioning Checklist – RPSLinkEX 3Φ				
Phase	Step	Checklist Item	Status (OK / Pending / N/A)	Comments / Notes
Phase – 1 Pre-commissioning and Documentation Review	1.1	Verify design documentation set (single-line diagrams, layout, control logic, network diagram)		
	1.2	Confirm permits, interconnection approvals, and utility witness test plan readiness		
	1.3	Review as-built wiring vs drawings; mark deviations		
	1.4	Verify system labeling, nameplates, and warning signage		
	1.5	Safety documentation — lockout/tagout plan, emergency response plan		
	1.6	Verify quality QA/QC checks completed for RPSLinkEX 3Φ and site-specific Infrastructure		
Phase - 2 Mechanical & Installation Inspection	2.1	Check physical mounting of components are level / sufficient		
	2.2	Confirm system is located away from physical obstructions and has access for maintenance support		
	2.3	Inspect conduit entries and gland seals to be properly secured		
	2.5	Verify UIP Panel is secured		
Phase - 3 Electrical Verification (Before Energization)	3.1	ATS OPTION ONLY: Torque check on terminal block for utility connection to ATS (as per manufacturer spec)		
	3.2	ATS OPTION ONLY: Torque check on terminal block for load connection to ATS (as per manufacturer spec)		
	3.3	Torque check on Main Load OCPD inside User Interface Panel (as per manufacturer spec)		
	3.4	Torque check on Breaker connections for inverters x2 inside Electronic box (as per manufacturer spec). Load side and line side		
	3.5	Confirm system grounding/bonding continuity meets the NEC, verified by electrical contractor		
	3.6	Verify OCPD reset/close and open without issues		
	3.7	Verify auxiliary power circuits (control, UPS, Network Switch, VCOM)		
	3.8	Verify all ethernet connections are made to drawing		

Commissioning Checklist – RPSLinkEX 3Φ				
Phase	Step	Checklist Item	Status (OK / Pending / N/A)	Comments / Notes
	3.9	Verify all grounds are secured on the RPS50 batteries		
	3.10	Verify all grounds are secured on the Power Skid		
Phase - 4 Controls, Communication & Software	4.1	Power up control system on auxiliary power only (no DC main contactors/disconnect closed)		
	4.2	Test communication links (VCOM ↔ HMI ↔ PCS)		
	4.3	Verify alarms and event logging functions		
	4.4	Verify VCOM antenna connections are correct and secured		
	4.5	Verify VCOM communication (LTE, WiFi or Ethernet connection)		
Phase - 5 Functional / Dry Run Tests	5.1	Close main contactors under electrical contractor or engineering supervision (initial DC energization)		
	5.2	Run charge/discharge command tests at low power (< 10%)		
	5.3	Verify SOC reporting accuracy, voltage/current sensor calibration		
	5.4	Confirm alarm triggers: To HMI and to ViSTA system		
	5.5	Test emergency stop and system safe shutdown sequence		
	5.6	Verify RPSLinkEX 3Φ is visible and active on ViSTA Monitoring Platform		
Phase - 6 Performance / Integration Tests	6.1	Run charge/discharge command tests at low power capacity (< 10%)		
	6.2	Run charge/discharge command tests at mid power capacity (50%)		
	6.3	Run charge/discharge command tests at full power capacity (approx 100%)		
	6.4	ATS OPTION ONLY: Run full load with utility present through ATS to load		
	6.5	ATS OPTION ONLY: Shutdown utility and verify switchover to battery support through PCS		
	6.6	ATS OPTION ONLY: Run full load with support on battery power only (no utility present)		
	6.7	ATS OPTION ONLY: Turn utility back on, verify ATS switches back to normal utility operation		
	6.8	ATS OPTION ONLY: Charge battery unit to top of charge with utility present and supporting the load, verify stops and idles at top of charge		
Phase - 7 Final Acceptance & Documentation	7.1	Collect test data, sign-off sheets, torque records, calibration certificates		
	7.2	Train operations personnel on normal and emergency procedures		
	7.3	Submit commissioning report and punch-list closure		
	7.4	Provide as-built drawings and configuration backups as required		
	7.5	Transition to warranty/start of service period		

OPERATION



7. Startup

7.1 RPSLinkEX 3Φ General Startup Instructions

1 — Apply Power to the Unit

Move the selector switch on the User Interface Panel to the “ON / Normal” position.

The DEIF IE250 will power on.

Verify that utility/grid power is present.

2 — Utility Hold-Up Behavior

If the correct AC utility voltage is present, the unit will remain powered even if the selector switch is returned to the “OFF” position.

Step 1 — Access WebVisu

On the front HMI (DEIF IE250), tap the **back arrow**, then select “WebVisu.”

Step 2 — Accept Connection

Select “Accept.”

Step 3 — Verify Unit Mode

Open the bottom menu and select “Settings.”

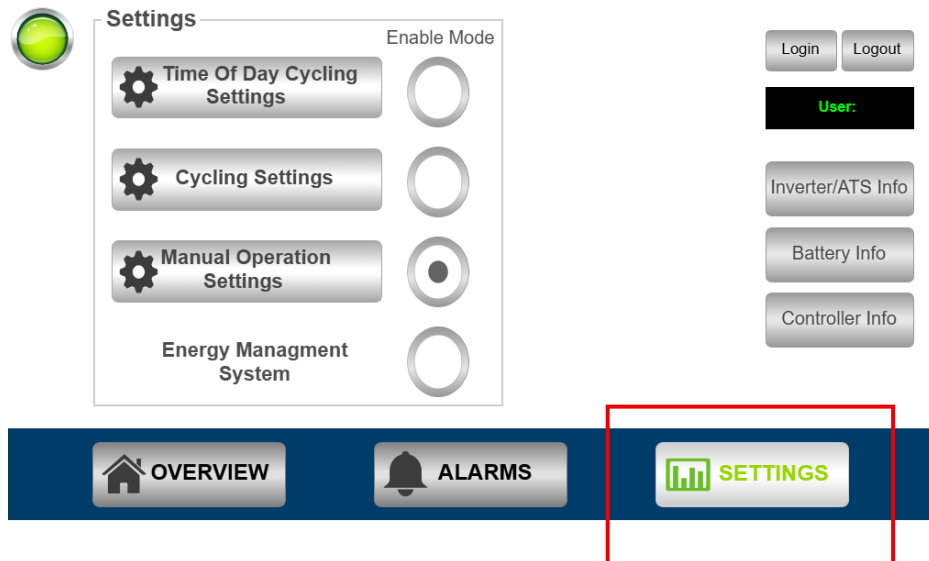

Step 4 — Select Operating Mode & Setpoints

Choose the desired mode and configure the associated setpoints:

1. Time of Day

Allows input of time-of-day schedule, SOC limits, and charge/discharge power setpoints.

2. Cycling

Allows input of power setpoints. The unit automatically cycles from top of charge to bottom of charge repeatedly.

3. Manual Operation

Allows direct power command input. The unit will charge or discharge according to the setpoint.

4. EMS - *Optional*

Non-configurable. Unit follows all commands from the external EMS.

5. Offgrid

Allows unit to carry load (not for On-Grid use).

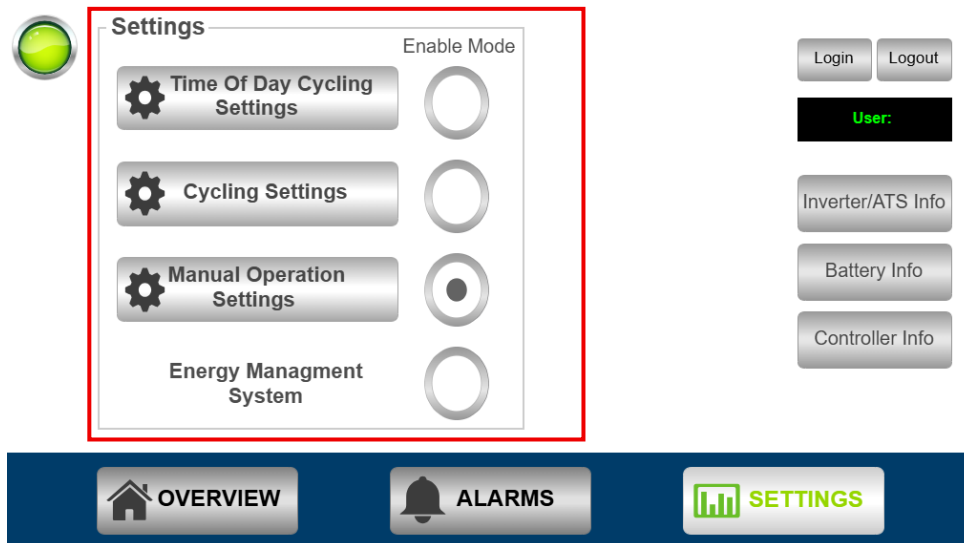

Step 5 — Start the System

On the **Overview** tab, select “Tap to Start.”

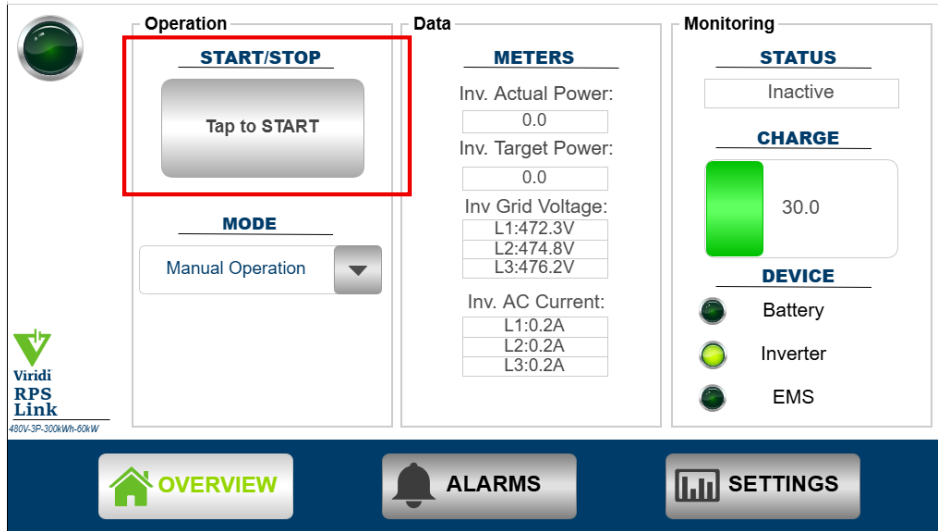

Step 6 — Verify Output

Confirm the unit is producing the desired power setpoint.

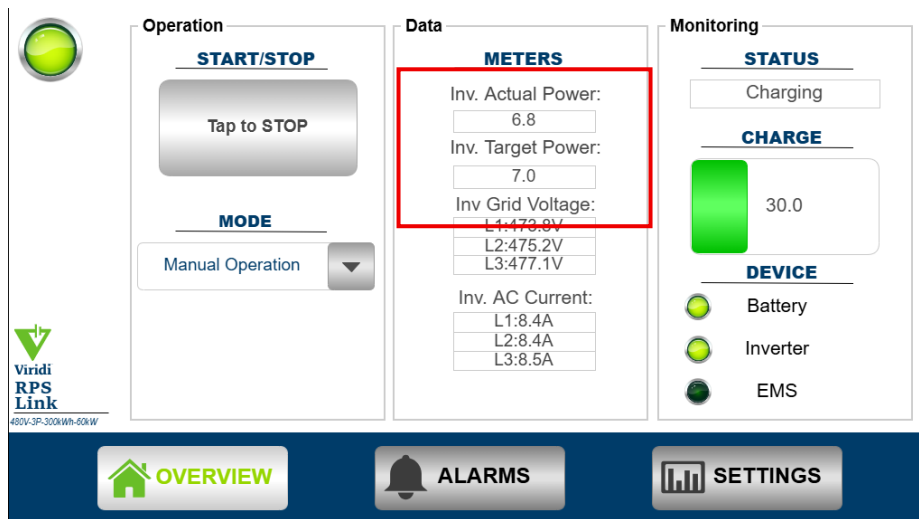

7.2 RPSLinkEX 3Φ Advanced Settings

Advanced Settings (Ramp Rate & Fan Mode)

Step 7 — Login for Advanced Configuration

To change ramp rate, fan mode or Offgrid mode:

- Select “Login.”
- Password: 1001

The screenshot displays the 'Settings' interface for the RPSLinkEX 3Φ system. The 'Settings' panel is titled 'Settings' and includes a green circular icon. It lists four settings categories, each with a gear icon and an 'Enable Mode' radio button:

- Time Of Day Cycling Settings**: Enable Mode radio button is selected.
- Cycling Settings**: Enable Mode radio button is unselected.
- Manual Operation Settings**: Enable Mode radio button is unselected.
- Energy Management System**: Enable Mode radio button is unselected.

To the right of the settings panel is a login panel, highlighted with a red border. It contains the following elements:

- 'Login' and 'Logout' buttons at the top.
- A black input field with the label 'User:' in green text.
- Buttons for 'Inverter/ATS Info', 'Battery Info', and 'Controller Info' below the input field.

At the bottom of the interface is a dark blue navigation bar with three buttons: 'OVERVIEW' (with a house icon), 'ALARMS' (with a bell icon), and 'SETTINGS' (with a bar chart icon and highlighted in green).

Step 8 — Verify Fan Mode

Fan Mode Options:

- **On:** Fan runs continuously.
- **Off:** Fan stays off.
- **Auto:** Fan turns on/off automatically as needed.

Settings

Enable Mode

Time Of Day Cycling Settings

Cycling Settings

Manual Operation Settings

Energy Management System

Other Settings

Offgrid

Set Power Increase Rate (kW/sec)

6.00

Fan Control

AUTO

Login Logout

User: Administrator

Inverter/ATS Info

Battery Info

Controller Info

Version:1.3.1.0

OVERVIEW ALARMS SETTINGS

Step 9 — Adjust Ramp Rate

Use the ramp-rate increase to set the desired **kW/sec inverter ramp rate**.

The screenshot displays the 'Settings' page of the Viridi RPSLinkEX 3Φ web interface. On the left, under the 'Settings' header, there are four sections: 'Time Of Day Cycling Settings', 'Cycling Settings', 'Manual Operation Settings', and 'Energy Management System'. Each section has a gear icon and a corresponding 'Enable Mode' toggle switch. The 'Time Of Day Cycling Settings' toggle is currently turned on. In the center-right area, under 'Other Settings', the 'Set Power Increase Rate (kW/sec)' field is highlighted with a red box and shows a value of '6.00'. Below this is the 'Fan Control' section with an 'AUTO' button. On the right side, there are 'Login' and 'Logout' buttons, a user status indicator showing 'User: Administrator', and buttons for 'Inverter/ATS Info', 'Battery Info', and 'Controller Info'. At the bottom right, the version number 'Version:1.3.1.0' is displayed. A dark blue navigation bar at the bottom contains three buttons: 'OVERVIEW' (with a house icon), 'ALARMS' (with a bell icon), and 'SETTINGS' (with a bar chart icon and highlighted in green).

8 SHUT DOWN

8.1 RPSLinkEX 3Φ Shutdown Instructions

- Step 1 — Stop the System**
 On the **Overview** tab, select **“Tap to Stop.”**
 The system should cease power production, and the batteries will shut down.
- Step 2 — Verify Utility Status**
 Confirm that **no utility/grid power** is present before proceeding.
- Step 3 — Turn Off the Main Switch**
 On the front of the unit, toggle the main power switch to the **“OFF”** position.

The screenshot displays the control interface for the RPSLinkEX 3Φ system. The interface is divided into three main sections: Operation, Data, and Monitoring. The 'Operation' section contains a 'START/STOP' button with 'Tap to STOP' text, which is highlighted with a red box. Below it is a 'MODE' dropdown menu set to 'Manual Operation'. The 'Data' section, titled 'METERS', displays various power and voltage metrics. The 'Monitoring' section shows the system status as 'Charging', a 'CHARGE' level of 30.0, and a 'DEVICE' list including Battery, Inverter, and EMS. At the bottom, there are navigation buttons for 'OVERVIEW', 'ALARMS', and 'SETTINGS'. The Viridi RPS Link logo and model number '482V-3P-300kWh-6kW' are visible in the bottom left corner.

Operation		Data		Monitoring	
START/STOP		METERS		STATUS	
Tap to STOP		Inv. Actual Power:	6.8	Charging	
		Inv. Target Power:	7.0	CHARGE	
MODE		Inv Grid Voltage:		30.0	
Manual Operation		L1:473.8V		DEVICE	
		L2:475.2V		Battery	
		L3:477.1V		Inverter	
		Inv. AC Current:		EMS	
		L1:8.4A			
		L2:8.4A			
		L3:8.5A			

MAINTENANCE



9. Maintenance

Note:

- Personnel performing maintenance on the RPSLinkEX 3Φ must be trained and familiar with the operation and configuration of RPSLinkEX 3Φ components.
- The BESS must be completely disconnected (external power source in a deenergized state with proper Lock Out – Tag Out [LOTO] devices installed) for all external connections and interfaces prior to any type of maintenance operation.
 - The only exception to this is when performing the thermal imaging check listed under 9.1.5. This system must be running to properly perform this check.
- Clearing and Cleaning - After installation and commissioning, regularly clean, check ventilation and air exhaust devices. Periodic cleaning is recommended, to start (based on environmental characteristics) a three-month schedule is recommended. After installation and commissioning, regular fan, filters and inspection time and systems checks may be extended at customer discretion.
- If torquing of fitting and/or connections are required, verify the torque wrench has a current calibration sticker.
- If any maintenance is performed that involves disturbing electrical connections, ensure that connections are re-torqued to specification afterwards.

9.1 Periodic Scheduled Maintenance

The following are recommended scheduled maintenance check/verification for the internal/external components of the RPSLinkEX 3Φ

Task List <i>(see 9.1.1 thru 9.1.5 below for item locations and detail)</i>	Commissioning	Monthly	Quarterly	Semi-Annually	Annually	As Indicated
9.1.1 Sinexcel Inverters - Vacuum all dust and debris from the unit			X			
9.1.1 Sinexcel Inverters - Using low pressure compressed air source, blow air through the mesh and fans			X			
9.1.2 Switchgear - General inspection inside of the enclosure for contaminants and/or dust	X			X		
9.1.2 Main Enclosure – preventative maintenance check for intake/exhaust filter and exhaust fan					X	
9.1.3 General Electrical and Bolt interface connections - Check for oil, dust, oxidation, and contaminant accumulation	X				X	
9.1.4 Energy Management System Cabinet <i>(optional accessory external to RPSLinkEX 3Φ)</i> - Check for oil, dust, oxidation, and contaminants accumulating inside of the cabinet	X					X
9.1.5 Torque Checks – Perform thermal check OR torque mark check	X				X	

9.1.1 Sinexcel Inverter

General inspection of the Sinexcel inverters, mounting and electrical connections in accordance with the Sinexcel Operations manual (P/N: PWS2-30P-NA). General maintenance shall include but not be limited to:

- Vacuum all dust and debris from the unit
- Using a low pressure compressed air source, blow air through the mesh and fans

Note that the Sinexcel manual suggests quarterly general maintenance but based on the container being sealed and well-ventilated these can be reduced to annual checks, so long as the container doors are not left open for extended periods of time.

9.1.2 System Enclosure

General inspection inside of the enclosure for contaminants and/or dust. Intake filter and exhaust fan cleaned by specification sheet. General maintenance shall include but not be limited to:

- There should be a general visual check of the units exterior and interior every 6 months to spot any possible hazards or issues.
- Intake and Exhaust Fan (P/N: 2410-00041, MFG P/N: HI-200SD(8"))
 - Clean inside of cabinet with low pressure compressed air, visually inspect fan blades
- Intake Filter (P/N: 2410-00036, MFG P/N: F-245P-500F)
- Filter Manufacturer recommends replacing the filter (2410-00046) every 9-12 months based on environment.
 - Visually inspect filter every 6 months to ensure there are no major blockages. Inspection should occur more often if unit is installed in a high dust environment.

9.1.3 General Electrical and Bolt Interface Connections

Check for oil, dust, oxidation, and contaminants accumulating on or around electrical components

- If oil, dust or contaminants are found on or around electrical components, use low pressure air and a clean microfiber cloth to clean connections
- If oxidation is found on or around electrical components, contact Viridi customer service for oxidation removal procedure.

9.1.4 Energy Management System (EMS) Cabinet(s)

Energy Management System (EMS) is an optional cabinet or cabinets external to the RPSLinkEX 3Φ product components

Check for oil, dust, and contaminants accumulating inside of the cabinet

- If oil, dust or contaminants are found on or around electrical components, use low pressure air and a clean microfiber cloth to clean connections
- If oxidation is found on or around electrical components, contact Viridi customer service for oxidation removal procedure.

9.1.5 Torque Check

Check proper torque for all identified electrical connections. Torque checks can be performed by thermal imaging OR torque mark visual OR torque value checks.

- **Thermal Imaging Check** – perform thermal imaging procedure with unit in operation. Compare with the thermal imaging control provided by Viridi to determine hot spots. If hot spots are located, check torque with proper torque wrench after

following disconnect and LOTO procedures. Note: Thermal imaging procedure and control may not be available initially. Viridi to provide information once procedure and control are established.

- **Torque Mark Visual Check** – Any fasteners that have a clear torque mark indicator (paint pen running across fastener head onto electrical component) can be visually inspected to ensure there is no break in the torque mark indicator between the fastener and component. Note: not all fasteners will have torque mark indicators and will need to be checked with thermal imaging or torque value checks.
- **Torque Value Check** – Use a calibrated torque wrench to manually check each electrical connection's torque value in accordance with the torque values provided in the table below and the corresponding figures/locations

9.1.5.1 Torque Check Table

Component	Location(s)	Torque Value [Nm]	Frequency	MFR PN
125A Main Breaker	[A]	9Nm +/- 0.9	Annually	Schneider BDL36125
3 Pole Distribution block	[B]	56.55Nm +/- 2.8	Annually	Eaton 16378-1
1 Pole Distribution block GND	[B]	12.4Nm +/- 0.6	Annually	Eaton 16204-1
Inverter 3Φhase connection (1 or 2)	[C]	5.1Nm +/- 0.3	Annually	Contact Viridi
PWD-100M Intelligent Switch Module (Optional)	[C]	20Nm +/- 1.0	Annually	Contact Viridi

Warning

Verify All External Power Is Off and Switches Are in the OFF Position

9.1.5.2 Torque Reference Images.

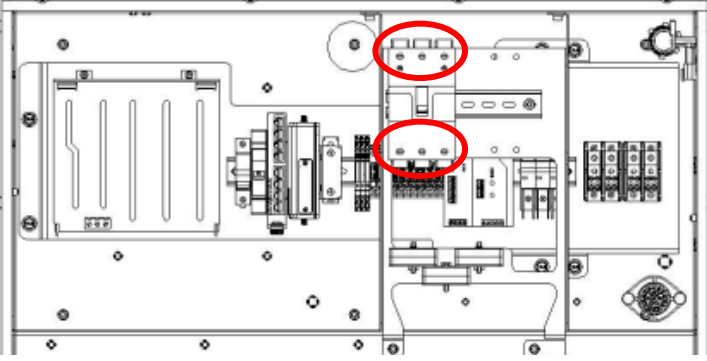
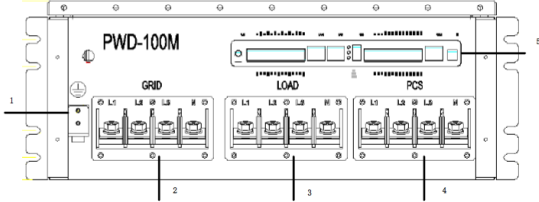
The following identifies the specific location and image description of the components requiring torque checks

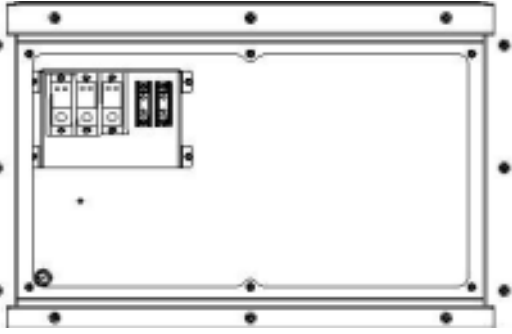
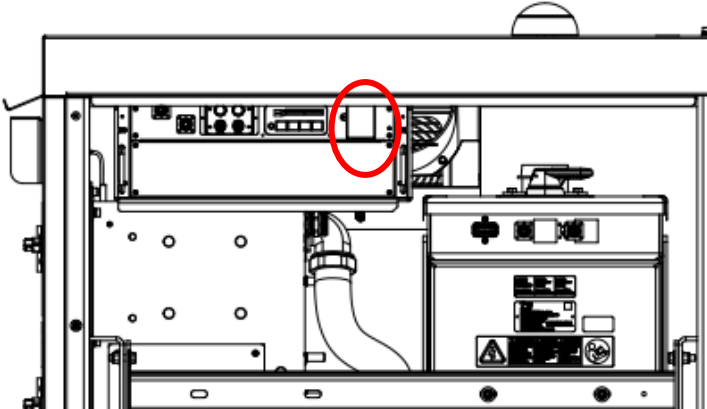
Location (description)	Image
Location A – Electronics Box. 1 – 125 Amp Breaker	
Location C – Intelligent Switch module location (Optional)	

Location (description)	Image
Location B – Power Skid 3 – 3 Φ ole distribution block 4 – 1pole distribution block	
Location C – Inverter Terminal Block (4 positions)	

9.2 Decommissioning

- Contact Viridi first
 - a) Perform 1 final physical inspection.
 - b) Lower SOC to 30% SOC.
 - c) Go through a shutdown procedure (Reference Section 8.1 Shut Down)
 - d) Disconnect all exterior/customer connections (Utility connection, ethernet, CANBUS, Fiber connection, etc..).
 - e) Plug / Seal any holes left in the customer connection panel
 - f) Open all Breakers on the UIP panel
 - g) Visually Validate everything in the unit is powered off

9.3 ViSTA Alarm Definition Glossary

Severity	Description	High Level Definition
Critical	Requires Immediate Attention	Anything that can cause the unit, or the "Grid" to shut down <i>Ex. E-Stop Pressed</i>
Major	High Impact to Functionality	Anything that can cause the unit to go down or a major component to go down <i>Ex. Inverter Alarms or Battery DTC Alarms</i>
Warning	Does not impact functionality right away	Does not impact on the overall functionality but if this state continues, it will lead to an alarm (either minor, or/and major). <i>Ex. Temperature Alarms</i>

9.4 ViSTA Alarms

Here are some of the common ViSTA alarms, their severity, and a brief explanation along with the action needed to resolve them.

Alarm Name	Severity	Triggered By	Description / Take Action
E-STOP Activated	CRITICAL	E-STOP	Emergency Stop pressed. Disengage E-Stop and Power Cycle BESS.
EMS Communication Lost (Optional)	MAJOR	HMI	RPSLINK to Viridi Energy Management System lost. Contact Viridi Customer Service.
ViSTA Connection Lost to Asset	MAJOR	ViSTA Cloud	Communications failure between VCom and ViSTA Cloud. Check wired internet connection (if applicable) and LTE coverage. If an error persists, call Viridi Customer Service.
String "X" BMS Temperature Warning	MAJOR	String "X" BMS	BMS on String X senses the battery cell temperature too high. Ensure fan filters are clear, and BESS is ventilating properly.
String "X" BMS Temperature High Error	MAJOR	String "X" BMS	BMS on String X senses the battery cell temperature too high. Ensure fan filters are clear, and BESS is ventilating properly.
String "X" Inverter AC Bus Over Voltage	MAJOR	String "X" Inverter	Inverter on String X senses AC voltage is too high. Check source voltage (can be done through the Deif HMI or ViSTA). If an error persists, call customer service.
String "X" Inverter AC Bus Under Voltage	MAJOR	String "X" Inverter	Inverter on String X senses AC voltage is too low. Check source voltage (can be done through the Deif HMI or ViSTA). If an error persists, call customer service.
String "X" Inverter AC Bus Over Frequency	MAJOR	String "X" Inverter	Inverter on String X senses AC frequency is above conformance. Check frequency (can be done through the Deif HMI or ViSTA). If an error persists, call customer service.
String "X" Inverter AC Bus Under Frequency	MAJOR	String "X" Inverter	Inverter on String X senses AC frequency is below conformance. Check frequency (can be done through the Deif HMI or ViSTA). If an error persists, call customer service.
String "X" Inverter AC Bus Phase Reversed	MAJOR	String "X" Inverter	Inverter on String X senses AC phase (L1, L2, L3) are incorrect orientation. Check AC wiring to BESS.

Alarm Name	Severity	Triggered By	Description / Take Action
String "X" Inverter AC Bus Voltage Asymmetric	MAJOR	String "X" Inverter	Inverter on String X senses AC voltage asymmetry. Check source voltage (can be done through the Deif HMI or ViSTA). If an error persists, call customer service.
String "X" Inverter AC Bus Voltage Abnormal	MAJOR	String "X" Inverter	The inverter on String X senses AC voltage that is too high or too low for operation. Check source voltage (can be done through the Deif HMI or ViSTA). If an error persists, call customer service.
String "X" Inverter AC Bus Phase Lost	MAJOR	String "X" Inverter	The inverter on String X does not sense AC power. Ensure BESS is in the correct operational mode and that String level and system level breakers and contactors are closed. If an error persists, call customer service.
String "X" Inverter AC Overload Timeout	MAJOR	String "X" Inverter	Inverter on String X overload timeout. Load exceeded rated value; code will clear once load is under limit for 5 minutes. If an error persists, call customer service.
String "X" Inverter High Temperature Warning	MAJOR	String "X" Inverter	Inverter on String X senses internal temperature at AC or DC radiator too high. Ensure fan filters are clear, and BESS is ventilating properly.
String "X" Inverter High Temperature Error	MAJOR	String "X" Inverter	Inverter on String X senses internal temperature at AC or DC radiator too high. String offline. Ensure fan filters are clear, and BESS is ventilating properly. String will not function until inverter temperature drops to a safe threshold.
String "X" Inverter High Ambient Temperature Warning	MAJOR	String "X" Inverter	Inverter on String X senses ambient temperature too high. Ensure fan filters are clear, and BESS is ventilating properly.
String "X" Inverter High Ambient Temperature Error	MAJOR	String "X" Inverter	Inverter on String X senses ambient temperature too high. String offline. Ensure fan filters are clear, and BESS is ventilating properly. String will not function until inverter temperature drops to a safe threshold.
String "X" Discharge Limit Enforcement Fault	MAJOR	String "X" PLC	Error code generated by RPS50 Battery Management System [Orion BMS2]. Call Viridi Customer Service.
String "X" Charger Safety Relay Fault	MAJOR	String "X" PLC	Error code generated by RPS50 Battery Management System [Orion BMS2]. Call Viridi Customer Service.
String "X" Internal Hardware Fault	MAJOR	String "X" PLC	Error code generated by RPS50 Battery Management System [Orion BMS2]. Call Viridi Customer Service.
String "X" Internal Heatsink Thermistor Fault	MAJOR	String "X" PLC	Error code generated by RPS50 Battery Management System [Orion BMS2]. Call Viridi Customer Service.
String "X" Internal Software Fault	MAJOR	String "X" PLC	Error code generated by RPS50 Battery Management System [Orion BMS2]. Call Viridi Customer Service.
String "X" Highest Cell Voltage Too High Fault	MAJOR	String "X" BMS	Error code generated by RPS50 Battery Management System [Orion BMS2]. Call Viridi Customer Service.
String "X" Lowest Cell Voltage Too Low Fault	MAJOR	String "X" BMS	Error code generated by RPS50 Battery Management System [Orion BMS2]. Call Viridi Customer Service.
String "X" Pack Too Hot Fault	MAJOR	String "X" BMS	Error code generated by RPS50 Battery Management System [Orion BMS2]. Call Viridi Customer Service.
String "X" High Voltage Interlock Signal Fault	MAJOR	String "X" BMS	Error code generated by RPS50 Battery Management System [Orion BMS2]. Call Viridi Customer Service.
String "X" Pre-charge Circuit Malfunction	MAJOR	String "X" BMS	Error code generated by RPS50 Battery Management System [Orion BMS2]. Call Viridi Customer Service.

Alarm Name	Severity	Triggered By	Description / Take Action
String "X" Abnormal State of Charge Behavior	MAJOR	String "X" BMS	Error code generated by RPS50 Battery Management System [Orion BMS2]. Call Viridi Customer Service.
String "X" Internal Communication Fault	MAJOR	String "X" BMS	Error code generated by RPS50 Battery Management System [Orion BMS2]. Call Viridi Customer Service.
String "X" Cell Balancing Stuck Off Fault	MAJOR	String "X" BMS	Error code generated by RPS50 Battery Management System [Orion BMS2]. Call Viridi Customer Service.
String "X" Weak Cell Fault	MAJOR	String "X" BMS	Error code generated by RPS50 Battery Management System [Orion BMS2]. Call Viridi Customer Service.
String "X" Low Cell Voltage Fault	MAJOR	String "X" BMS	Error code generated by RPS50 Battery Management System [Orion BMS2]. Call Viridi Customer Service.
String "X" Open Wiring Fault	MAJOR	String "X" BMS	Error code generated by RPS50 Battery Management System [Orion BMS2]. Call Viridi Customer Service.
String "X" Current Sensor Fault	MAJOR	String "X" BMS	Error code generated by RPS50 Battery Management System [Orion BMS2]. Call Viridi Customer Service.
String "X" Highest Cell Voltage Over 5V Fault	MAJOR	String "X" BMS	Error code generated by RPS50 Battery Management System [Orion BMS2]. Call Viridi Customer Service.
String "X" Cell ASIC Fault	MAJOR	String "X" BMS	Error code generated by RPS50 Battery Management System [Orion BMS2]. Call Viridi Customer Service.
String "X" Weak Pack Fault	MAJOR	String "X" BMS	Error code generated by RPS50 Battery Management System [Orion BMS2]. Call Viridi Customer Service.
String "X" Fan Monitor Fault	MAJOR	String "X" BMS	Error code generated by RPS50 Battery Management System [Orion BMS2]. Call Viridi Customer Service.
String "X" Thermistor Fault	MAJOR	String "X" BMS	Error code generated by RPS50 Battery Management System [Orion BMS2]. Call Viridi Customer Service.
String "X" External Communication Fault	MAJOR	String "X" BMS	Error code generated by RPS50 Battery Management System [Orion BMS2]. Call Viridi Customer Service.
String "X" Redundant Power Supply Fault	MAJOR	String "X" BMS	Error code generated by RPS50 Battery Management System [Orion BMS2]. Call Viridi Customer Service.
String "X" High Voltage Isolation Fault	MAJOR	String "X" BMS	Error code generated by RPS50 Battery Management System [Orion BMS2]. Call Viridi Customer Service.
String "X" Input Power Supply Fault	MAJOR	String "X" BMS	Error code generated by RPS50 Battery Management System [Orion BMS2]. Call Viridi Customer Service.
String "X" Charge Limit Enforcement Fault	MAJOR	String "X" BMS	Error code generated by RPS50 Battery Management System [Orion BMS2]. Call Viridi Customer Service.
String "X" Max Charge Reached	Warning	HMI	Notification that Strings "x" hit the max charge. No action is needed.
String "X" Max Discharge Reached	Warning	HMI	Notification that Strings "x" hit the max discharge. No action is needed.

Additional Alarms with Optional Intelligent Switching Device

Alarm Name	Severity	Triggered By	Description / Take Action
ATS Fault System Fault (Optional)	CRITICAL	HMI	ATS system fault. Please Contact Customer Service.
ATS Fault System Failure (Optional)	CRITICAL	HMI	ATS system failure. Please Contact Customer Service.
ATS Load Overload Timeout (Optional)	MAJOR	HMI	ATS has an alarm. Please contact customer service.
ATS Load Overload Alarm (Optional)	MAJOR	HMI	ATS has an alarm. Please contact customer service.
ATS Load Neutral Overcurrent (Optional)	MAJOR	HMI	ATS has an alarm. Please contact customer service.
ATS Load Voltage Abnormal (Optional)	MAJOR	HMI	ATS has an alarm. Please contact customer service.
ATS Load Phase Reversed (Optional)	MAJOR	HMI	ATS has an alarm. Please contact customer service.
ATS Force Bypass (Optional)	MAJOR	HMI	ATS has an alarm. Please contact customer service.
ATS Galvanic Break Short (Optional)	MAJOR	HMI	ATS has an alarm. Please contact customer service.
ATS Galvanic Break Open (Optional)	MAJOR	HMI	ATS has an alarm. Please contact customer service.
ATS Synchronization Failed (Optional)	MAJOR	HMI	ATS has an alarm. Please contact customer service.
ATS Frequent Switching Fault (Optional)	MAJOR	HMI	ATS has an alarm. Please contact customer service.
ATS Grid Overload Timeout (Optional)	MAJOR	HMI	ATS has an alarm. Please contact customer service.
ATS Grid Overload Alarm (Optional)	MAJOR	HMI	ATS has an alarm. Please contact customer service.
ATS Grid Neutral Overcurrent (Optional)	MAJOR	HMI	ATS has an alarm. Please contact customer service.
ATS Grid Connection Forbidden (Optional)	MAJOR	HMI	ATS has an alarm. Please contact customer service.
ATS Grid Power Down (Optional)	MAJOR	HMI	ATS has an alarm. Please contact customer service.
ATS Grid Neutral Lost (Optional)	MAJOR	HMI	ATS has an alarm. Please contact customer service.
ATS Grid Phase Lost (Optional)	MAJOR	HMI	ATS has an alarm. Please contact customer service.
ATS Grid Voltage Abnormal (Optional)	MAJOR	HMI	ATS has an alarm. Please contact customer service.
ATS Grid Voltage Asymmetric (Optional)	MAJOR	HMI	ATS has an alarm. Please contact customer service.
ATS Grid Phase Reversed (Optional)	MAJOR	HMI	ATS has an alarm. Please contact customer service.
ATS Grid Under Frequency (Optional)	MAJOR	HMI	ATS has an alarm. Please contact customer service.
ATS Grid Over Frequency (Optional)	MAJOR	HMI	ATS has an alarm. Please contact customer service.
ATS Grid Under Voltage (Optional)	MAJOR	HMI	ATS has an alarm. Please contact customer service.
ATS Grid Over Voltage (Optional)	MAJOR	HMI	ATS has an alarm. Please contact customer service.

9.5 Contact Viridi Customer Service

If an issue is identified with the RPSLinkEX 3Φ, please contact Viridi Customer Support at 1-866-984-7434

The following information will be requested:

Company Name	
Contact Name and Call Back #:	
Serial Number:	
Set Up Details:	
Fault Details, including history relevant to the fault:	