



Installation, Operation, & Maintenance Manual



RPS1200

(9920-00091)

LARGE SCALE BATTERY ENERGY STORAGE SOLUTION

Revision A: Released 17-Nov-2025

Contents

Contents	2
1. Notice	6
2. Safety	8
2.1 Warnings, Cautions, and Important Notes	8
2.2 Battery Precautions	10
2.3 Disposal and Recycling	10
2.4 Noise Level	10
3. AFP Fire Suppression System	11
3.1 Fire Suppression Agent System	11
3.2 Fire Department Water Sprinkler Hook-Up	11
3.1 Emergency Response Plan	12
4. System Overview	14
4.1 RPS1200 Overview	14
4.2 Fail-Safe Anti-Propagation Technology	14
4.3 Physical Parameters	15
4.4 Performance	16
4.5 Internal Equipment Configuration	16
4.5.1 Skid Numbering	17
4.6 Detailed Major Equipment Configuration Elements	18
4.7 System Diagrams	21
4.8 RPS1200 Certifications	22
5. ViSTA	23
5.1 Logging In	23
5.2 ViSTA Dashboard	24
5.2.1 The Container View	24
5.2.2 Data Over Time	25
5.2.3 Fleet Dashboard	26
6. Installation	28
6.1 Location Considerations	28

6.2	EMI/EMC Considerations	28
6.2.1	Definitions.....	28
6.3	Handling and Transport.....	29
6.4	Wiring Install Instructions.....	30
6.4.1	Punch out Necessary Hole in Customer Connection Panel.....	30
6.4.2	Open the Gutter	31
6.4.3	Locate Terminal Blocks.....	31
6.4.4	Connect Wires to Terminal Blocks	31
6.4.5	Reattach the Gutter Housing.....	32
6.5	Commissioning	33
6.5.1	Introduction.....	33
6.5.2	RPS1200 Commissioning Checklist.....	33
7.	Startup	37
7.1	RPS1200 General Startup Instructions	37
7.1.1	Access the Front User Interface (UI) Panel	37
7.1.2	Ensure All Breakers and Disconnects Are in the ON Position.....	37
7.1.3	Engage the UPS Start Switch	38
7.1.4	Confirm Low Voltage Power Activation	38
7.1.5	Verify and Wait for Battery Communication on User Interface.....	38
7.2	RPS1200 Off-Grid Startup Instructions	39
7.2.1	Enter Off-Grid Standby Mode	39
7.2.2	Verify Inverter Initialization	40
7.2.3	Start Off-Grid Discharge Mode	41
7.2.4	Confirm Inverters are Engaged and Power Output.....	41
7.3	RPS1200 On-Grid Startup Instructions	42
7.3.1	Enter On-Grid mode and Start Standby	42
7.3.2	Verify Inverter Initialization	42
7.3.3	Start On-Grid Discharge Mode	43
7.3.4	Confirm Inverters are Engaged and Power Output.....	43
7.4	RPS1200 EMS Startup Instructions	44
7.5	RPS1200 Startup Procedure for other modes	44

8.SHUT DOWN.....	45
8.1 RPS1200 Shutdown Instructions.....	45
8.1.1 Navigate to the User Interface Screen.....	45
8.1.2 Turn Off the System.....	45
8.1.3 Access the Front User Interface (UI) Panel	46
8.1.4 System Power Down.....	46
8.1.5 Ensure UPS power switch is OFF	47
9.Maintenance.....	49
9.1 Periodic Scheduled Maintenance	49
9.1.1 American Fire Protection (AFP) Fire System.....	50
9.1.2 Thermo King Heating, Ventilating and Air Conditioning (HVAC) Inspection	50
9.1.3 Removal / Replace of HVAC Rodent Guard.....	50
9.1.4 Sinexcel Inverter	51
9.1.4 Control Box and Enclosure.....	51
9.1.5 General Electrical and Bolt Interface Connections.....	51
9.1.6 Energy Management System (EMS) Cabinet(s)	51
9.1.7 Torque Check.....	51
9.1.7.1 Torque Check Table	52
Warning.....	52
Verify All External Power Is Off and Switches Are in the OFF Position	52
9.1.7.2 Torque Reference images.....	52
9.1.8 Water Intrusion	54
9.2 Decommissioning	55
9.3 ViSTA Alarm Definition Glossary.....	56
9.4 ViSTA Alarms	57
9.5 Contact Viridi Customer Service.....	61

1. Notice

As an express condition of Viridi's warranty and to encourage utilization of industry best practices, Viridi requires that the installation, mobilization, and operation of the RPS1200 only be completed by, or at the direction of, a qualified professional as defined by the jurisdiction(s) within which the installation, mobilization, and operation occurs. Specific applications can vary, so please direct specific questions to Viridi's attention:

- Telephone: 716-968-8658
- In writing to: sales@viridiparente.com).

Viridi expressly disclaims liability for applications made in a manner inconsistent with this guide and/or in non-compliance with local building and electrical codes. This Installation, Operations & Maintenance Manual, incorporates all the terms and conditions of sale. All information provided in this manual is subject to change with or without notice.

Please refer to the warranty documents provided at the point-of-sales for further information.



SAFETY



2. Safety

To make the best and proper use of the RPS1200, all personnel handling or operating the RPS1200 are advised to follow these guidelines:

- Only fully trained and qualified personnel should operate or service the machine. Read and understand the Installation, Operations & Maintenance Manual before operating the equipment to make certain safe practices are followed, including service and maintenance intervals.
- If there is a defect or evidence of damage that might expose an employee to injury, the defective or damaged RPS1200 shall be removed from service, and no employee may use it until repairs and tests needed to render the equipment safe have been made.
- Always keep this Installation, Operations & Maintenance Manual in a convenient place for easy access.
- If this Installation, Operations & Maintenance Manual, is lost or damaged, contact Viridi Customer Service, referencing the equipment serial or asset number.
 - Customer Service: 1-800-984-7434
 - Parts Ordering: parts@viridiparente.com
 - Service Issues: service@viridiparente.com
 - Warranty Claims: warranties@viridiparente.com
- This Installation, Operations & Maintenance Manual should be considered part of the RPS1200 and remain with it.
- Constant efforts are made to improve the quality and performance of our products; it may be that some information in the User Manual differs from your equipment. If any questions arise, please contact Viridi Parente, Inc.
- All the information in this publication is based on the latest product information available at the time of printing. Viridi Parente, Inc. reserves the right to make changes to this Installation, Operations & Maintenance Manual, without notice or obligation.
- No part of this publication may be reproduced or copied without prior written permission from Viridi Parente, Inc.

2.1 Warnings, Cautions, and Important Notes



This “Safety Alert” symbol and others like it are in place to warn the operator of potential hazards. It means attention/become alert – the operator’s safety is involved!

This symbol can signify DANGER and, where used, documents a WARNING or CAUTION which is followed by text highlighting the potential hazard. This manual will detail the potential hazards so that necessary precaution(s) towards ensuring operator and equipment safety.

A WARNING signifies a situation whereby the operator, members of staff, or the public could be put in danger of personal injury by the improper operation of the RPS1200.

A CAUTION signifies a situation whereby damage to the RPS1200 or associated parts could be caused by improper operation of the RPS1200.

Symbols Used in This Manual

	Warning/Cautions		Wear Gloves
	Shock Hazard		Quality
	General Safety		Tip

General Precautions



COMPETENT PERSONNEL: The RPS1200 is intended for use by suitable qualified, trained, and competent personnel who have read and understand this manual and are familiar with the equipment and its intended use. A certain level of user competence is assumed when operating power generating equipment.



READ AND UNDERSTAND: Before personnel operate, service, or perform tasks on the equipment, the manual must be read and understood.



VENTILATION: Do not obstruct the air vents and allow adequate space around the RPS1200 for ventilation.



ELECTRICAL SAFETY: Follow all applicable electrical codes and standards. Ensure proper grounding and bonding of the system components. Use appropriate PPE, including high voltage gloves, safety glasses, protective clothing, and insulated tools when working on electrical connections.



PRECAUTIONS: Follow the precautions listed within this manual before operation and during operation, service, and maintenance activities for the safety of the operator and others and to protect the performance of the equipment.



WARNING LABELS: Keep warning and caution labels from becoming dirty or torn and replace them if they become damaged. Replacements can be obtained by contacting Viridi Parente, Inc.



SAFETY: Safety is an utmost concern. Safety statements are one of the primary ways to call attention to potential hazards associated with generator operations.



FIRE SAFETY: Install fire suppression systems as required by local codes and regulations. Ensure that fire extinguishers and other firefighting equipment are readily accessible and properly maintained.



EMERGENCY PROCEDURES: Establish and communicate emergency procedures, including shutdown protocols, evacuation routes, and first responder action plans. Ensure all personnel are trained in these procedures.

Warnings



CRUSH HAZARD: The RPS1200 is a crush hazard when elevated above ground level, and the area below the RPS1200 should be cleared before hoisting the RPS1200 above ground level.



DANGER OF FALLING: Do not stand on top of the RPS1200. The surface may be slippery.



SHOCK HAZARD: Authorized access only. Do not remove panels to access internal components of the RPS1200. There are no user-serviceable parts inside the RPS1200. Only qualified, competent personnel are permitted to service internal components. Unauthorized Persons attempting to do so will be at risk of electric shock.



SITE ACCESS: Restrict access to the installation site to authorized personnel only. Implement security measures such as fencing, surveillance, and access control systems to prevent unauthorized entry



HIGH VOLTAGE: The battery energy storage system contains high voltage components. Always de-energize the system before performing any maintenance or repairs. Use lockout/tagout procedures to ensure the system remains de-energized during work.



THERMAL RUNAWAY: Be aware of the risks associated with thermal runaway in lithium-ion batteries. Implement measures to detect and mitigate thermal runaway events, such as temperature monitoring and automatic shutdown systems.



CHEMICAL HAZARDS: Batteries contain hazardous chemicals that can pose health risks if released. In the event of a battery leak or spill, follow appropriate hazardous material handling procedures and use spill containment equipment.



MECHANICAL HAZARDS: Use proper lifting techniques and equipment when handling heavy battery packs. Ensure that battery packs are securely mounted and supported to prevent tipping or falling.

2.2 Battery Precautions

The chemicals and materials in the battery are stored in a sealed container, designed to withstand temperatures and pressures encountered during normal use. As a result, during normal use, there is no physical danger of ignition, explosion, or hazardous material leakage. There is only a risk of exposure if a battery is mechanically, thermally, or electrically abused. There is no user access to the batteries. Do not remove panels. For the RPS1200 to operate at an optimal capacity they should be stored in a cool, dry place away from direct sunlight and sources of heat.

2.3 Disposal and Recycling

The RPS1200 comprises components that must be disposed of responsibly. Many of the components can be reused or recycled. For advice on the safe and proper disposal of RPS1200, please contact the Viridi sales representative. Viridi Parente, Inc. partners with American Battery Technology Company to disassemble end of life battery cells into critical minerals to be reused.

2.4 Noise Level

RPS1200 produces 91 dB(A) measured at the maximum motor speed of 3550 RPM.

3. AFP Fire Suppression System

The AFP Fire Suppression system is comprised of two systems: a fire suppression agent system, and a fire department water sprinkler hook-up.

3.1 Fire Suppression Agent System

The first system is a gaseous system utilizing Fluoro-K as the suppression agent. This system is operated through AFP and will automatically activate if two of the smoke detectors in the unit identify a fire. In the event of a fire, AFP will alert the chosen contacts - please work with Viridi and AFP to set up the appropriate contacts in the area to be alerted in an emergency. If the installation is a permanent or long-term installation, AFP will work to set up a maintenance schedule on the system. Please see the system instructions to the right from AFP to understand the alarm conditions.

Suppression System Instructions

Normal Condition Green Power LED on
Monitoring company is notified

Trouble Condition Yellow Trouble LED on (Requires attention/Service)
Monitoring company is notified

Alarm Condition Red Alarm LED on (Requires attention/Service)
Monitoring company is notified

1st detector in alarm = Horn/Strobe Activates

2nd detector in alarm = Horn/Strobe Continues/Resounds if Silenced
10 second discharge delay starts

Discharge Condition Red LED on – Requires attention/Service

Horn/Strobe Continues/Resounds if Silenced
Discharge Occurs
Pressure Switch activates

Panel Switches

Acknowledge Switch = Will silence piezo buzzer in panel. (Resounds every 24 hours)

Signal Silence Switch = Will silence horn/strobe.

System Reset Switch = Will reset the panel and clear troubles and alarms.

Maintenance Key Switch

Disables tank solenoid and creates a trouble on panel.

Agent Cylinder

Gauge should be in the green area. Red area requires service.



24 Hour Emergency Service
716-438-7970

AFP, Albany Blvd. • Lockport, New York 14094

3.2 Fire Department Water Sprinkler Hook-Up

The second system is a fire department water sprinkler hook-up. This system is in place for the fire department to flood the unit with water if they deem necessary in an emergency. The fire department hook-up is located at the end of the unit opposite the electrical room. During installation, please ensure there is adequate clearance and accessibility around this connection point for the fire department to access in an emergency. This system requires no maintenance.

If an emergency develops with the AFP system, please call their emergency service hotline at 716-438-7970.

3.1 Emergency Response Plan

The RPS1200 includes internal fault mechanisms designed to prevent failures and subsequent risk hazards. However, Viridi cannot guarantee safety performance of the RPS1200 if the equipment is exposed to abuse, damage, or negligence.

If an installer or user happens to be exposed to the internal materials of the battery cell due to damage on the outer casing, the following actions are recommended:

- In Case of Inhalation: Leave the contaminated area immediately and seek medical attention.
- In Case of Skin Contact: Wash the contacted area thoroughly with soap and seek medical attention.
- In Case of Ingestion: Induce vomiting and seek medical attention.

If a fire breaks out at or near the location of the RPS1200, perform the following counter measures:

- In the event of a fire, appropriate extinguishing media should be used based on the type of incident. For battery-related fires, the system should be allowed to burn itself out while defensive firefighting strategies are employed to protect nearby exposures, if necessary. For non-battery-related fires, such as those occurring near an RPS1200 unit, suitable extinguishing agents, including water or an ABC fire extinguisher, should be utilized. Additionally, if a fire occurs adjacent to the RPS1200, water may be applied as a defensive measure to cool the unit, if deemed necessary.
- Follow the proper fire-fighting instructions. If a fire occurs when charging the RPS1200, provided it is safe to do so, disconnect the battery pack circuit breaker to shut off the power charge. If the battery pack is not on fire yet, extinguish the fire before the battery pack catches fire, preferably with water. If the battery pack within the RPS1200 is on fire, do not try to extinguish it, and evacuate people from the premises immediately.
- **WARNING: Explosion is possible if the battery pack within the RPS1200 experiences temperatures above 150°C (302°F). When a battery pack is burning, it will leak poisonous gases. Do not approach it.**
- To deal with an accident with the RPS1200 on land, refer to the site-specific emergency response plan, if available and move the damaged RPS1200 to a segregated location and call your local fire department or service engineer. Service inspection must be completed by Viridi or an authorized service center before the unit can be cleared for operation.
- Note that proper lockout/tagout procedures must be followed in such cases. To deal with an accident with the RPS1200 in the water, stay out of the water and do not touch anything if any part of the battery, inverter, or wiring is submerged. Do not use the submerged battery again.
 - Contact your Viridi Service Team for assistance at:
 - Customer Support Line: 1-866-984-7434
 - Email: service@viridiparente.com

SYSTEM OVERVIEW



4. System Overview

4.1 RPS1200 Overview

The RPS1200 is a large-scale containerized Lithium-Ion Battery Energy Storage System for commercial and industrial applications. It is a 480VAC 3 Φ AC-Coupled device capable of charging and discharging up to 240kW containing 1173.6kWh nameplate energy.

4.2 Fail-Safe Anti-Propagation Technology

Viridi's core value proposition lies in the Fail-Safe Anti-Propagation architecture built into RPS50 battery packs, each of which contains 48.9kWh of nameplate energy storage. UL9540A testing, which involves intentionally heating a cell within the pack to the point of thermal failure, demonstrated that Viridi's passive technology halts cell-to-cell thermal propagation with no detectable release of heat, sparks, smoke, or flames. The pack enclosure is built from $\frac{1}{4}$ " steel and IP55 rated for an extremely durable industrial design built to survive harsh environments. This technology makes Viridi's BESS uniquely suitable for safe deployments in and around occupied spaces and critical equipment.



4.3 Physical Parameters

Dimension	English	Metric
Length	238.5 inch	6057.9 mm
Width	96.0 Inch	2438.4 mm
Height	113.8 Inch	2890.5 mm
Weight	42,000 pounds	19,050 Kg

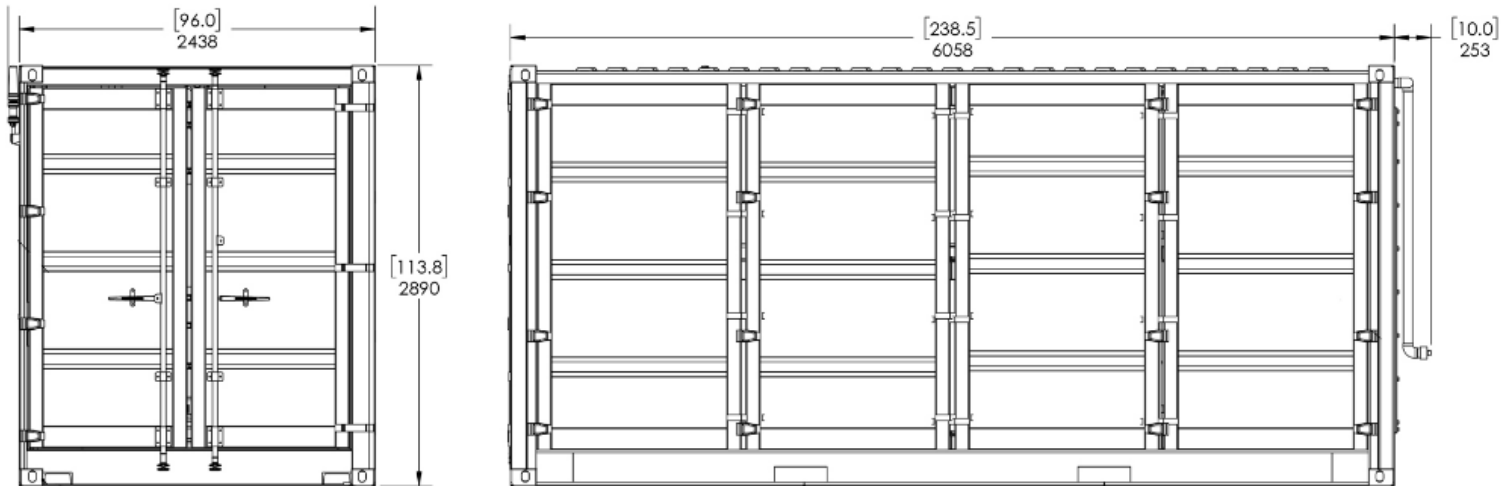

Overall Dimensioning

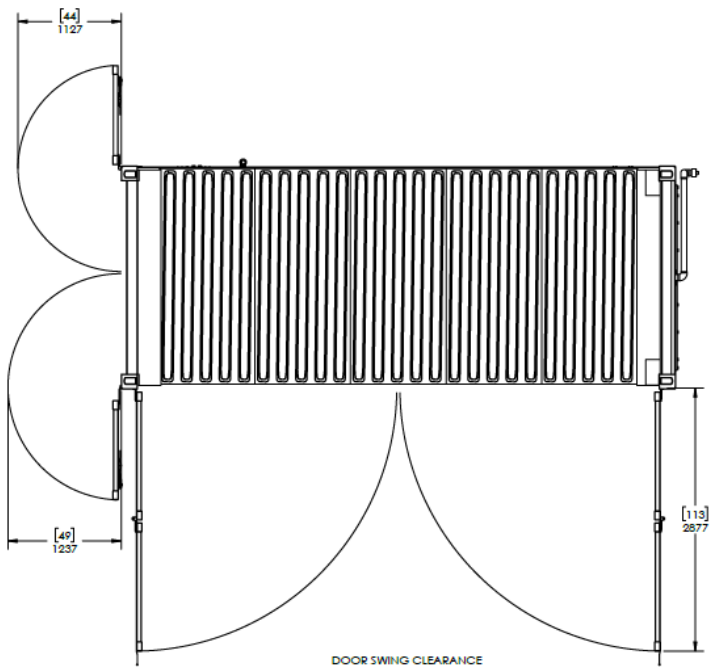

Top View Dimensioning with Access Doors Opened

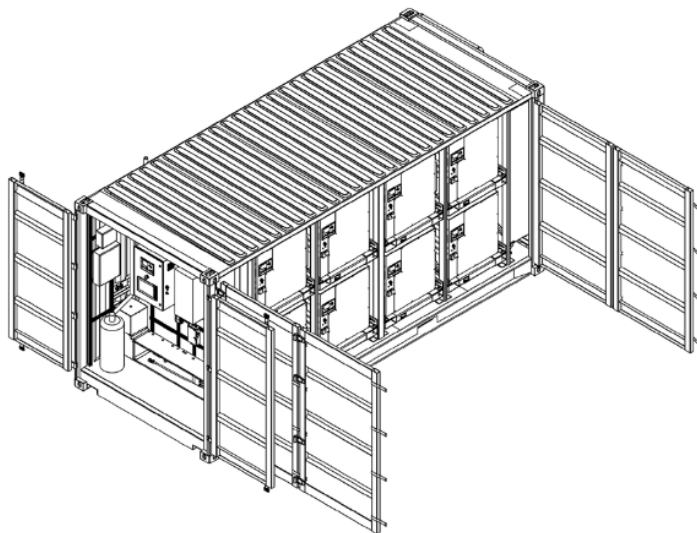

Isometric View

4.4 Performance

- **480V 3- Φ 3w AC-Coupled Design**
- **Discharge Parameters**
 - 240kW max continuous power
- **Charge Parameters**
 - 240kW max continuous power
- **Battery System**
 - Minimum to maximum battery pack operating temperature: -10°C to 45°C (14°F to 113°F)¹
 - 1,173.6kWh Nominal
 - 1041.8kWh Usable (DC) at approx. 90% DOD
 - 4,000 Cycles at Usable Capacity²

4.5 Internal Equipment Configuration

The following images are described as general equipment arrangement within the RPS1200 enclosure. For reference, the RPS1200 enclosure is shown with side panel and front access doors open.

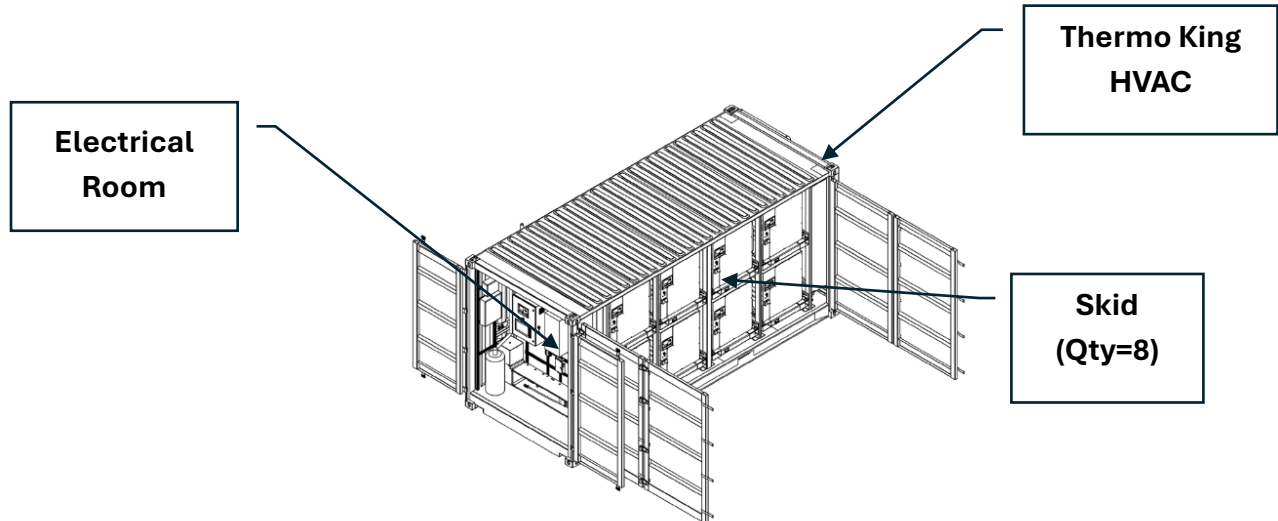

¹ Operating temperature range mirrors battery cell specifications. The Battery Management System (BMS) is programmed to manage the pack utilization rate to control the internal pack thermal conditions and prevent operation outside of pack interior temperature limits, which can be tailored for different applications/installations. The BMS communicates applicable operating conditions continuously via CAN bus to the inverter and/or system controller.

² Cycle life can be optimized for individual applications and operating conditions (depth of discharge, duty cycle, temperature, charge/discharge rate).

4.5.1 Skid Numbering

Skids are numbered 1 through 8 as shown in red below. This numbering scheme is referenced in:

- Human Machine Interface (HMI) screen
- ViSTA Dashboards
- ViSTA Diagnostic and Troubleshooting (DTC) Codes

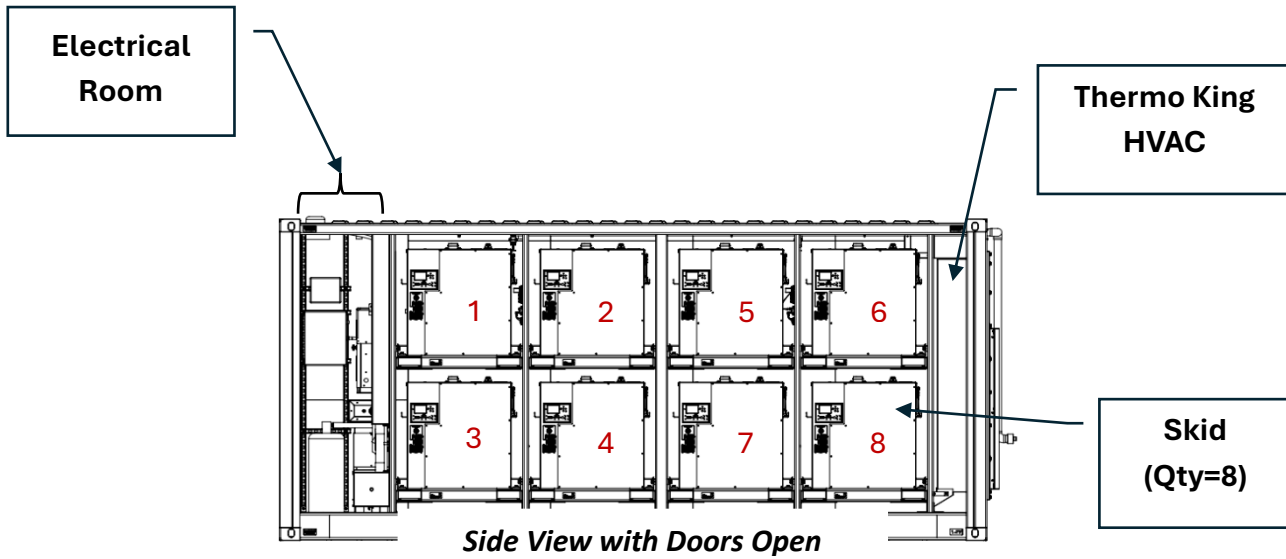

4.6 Detailed Major Equipment Configuration Elements

The following images are described as general equipment arrangement as sub-elements of the RPS1200 enclosure.

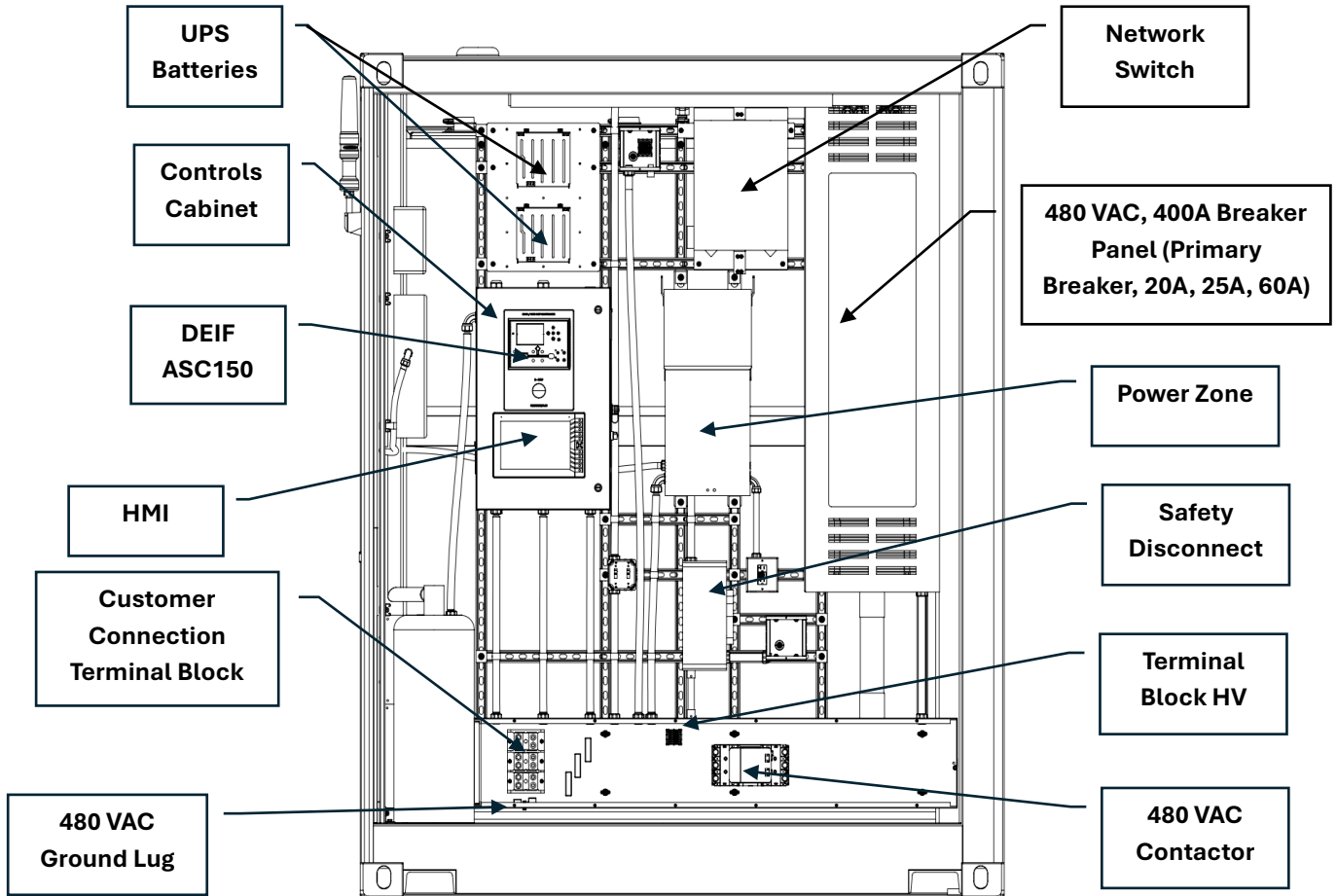

Electrical Room

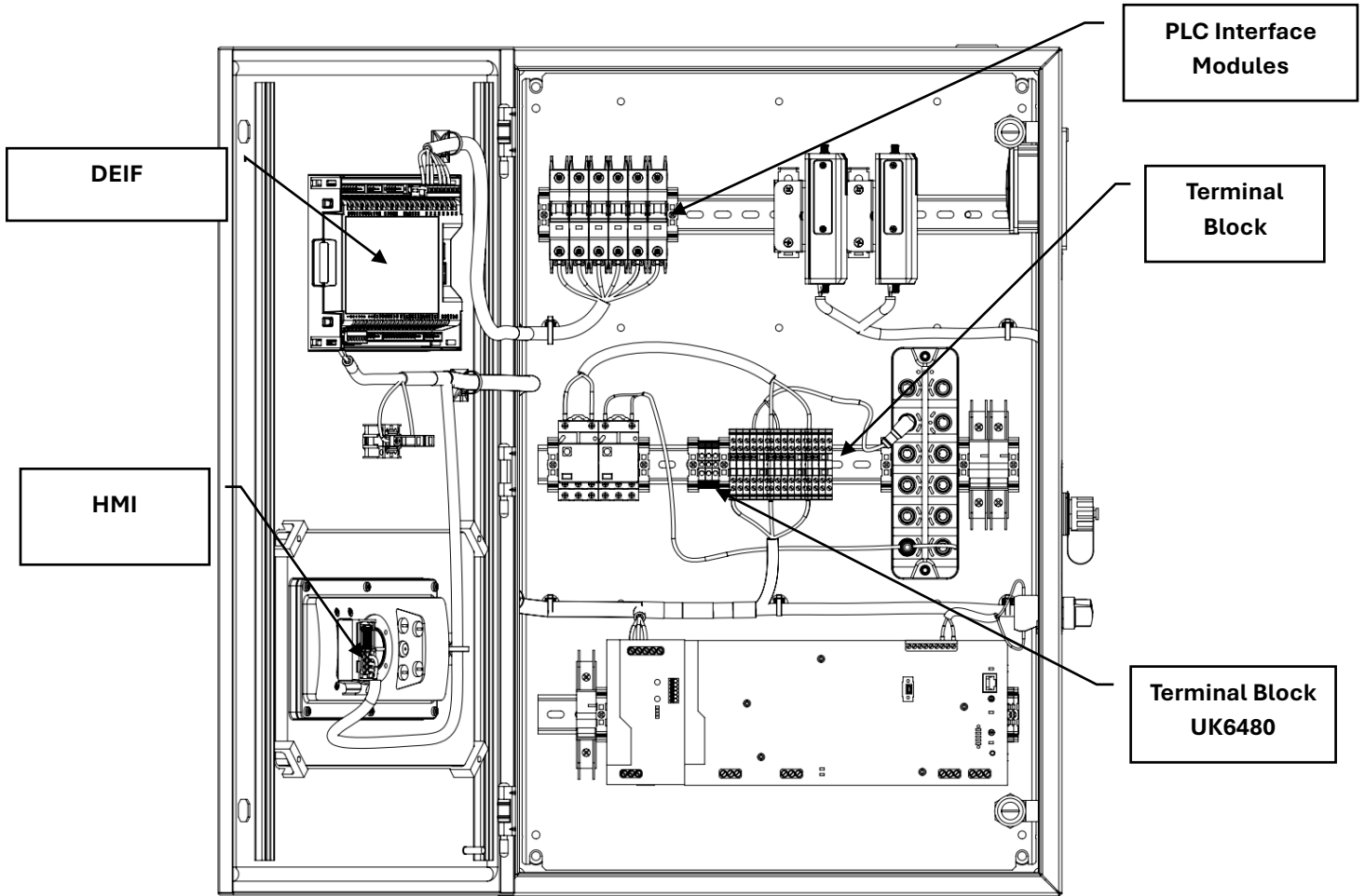

Controls Cabinet

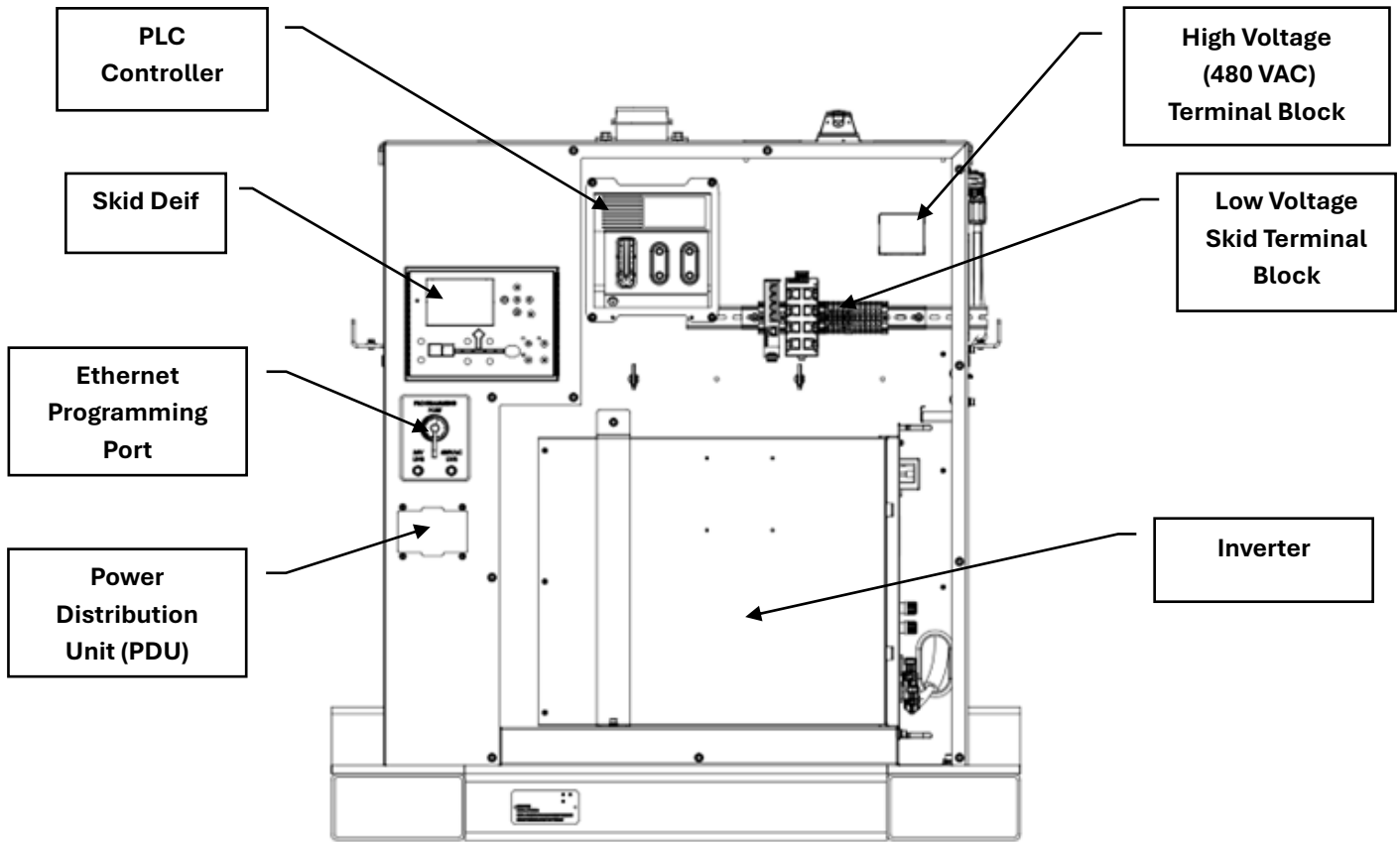

Skid
(QTY=8)

4.7 System Diagrams

Below are system diagrams defining the general architecture of the RPS1200 system, and the battery skid within the system. These are intended for general understanding of the unit's system design and operation and are not meant for in depth troubleshooting. If issues develop with the system or the system's wiring, please contact the Viridi support team for assistance.

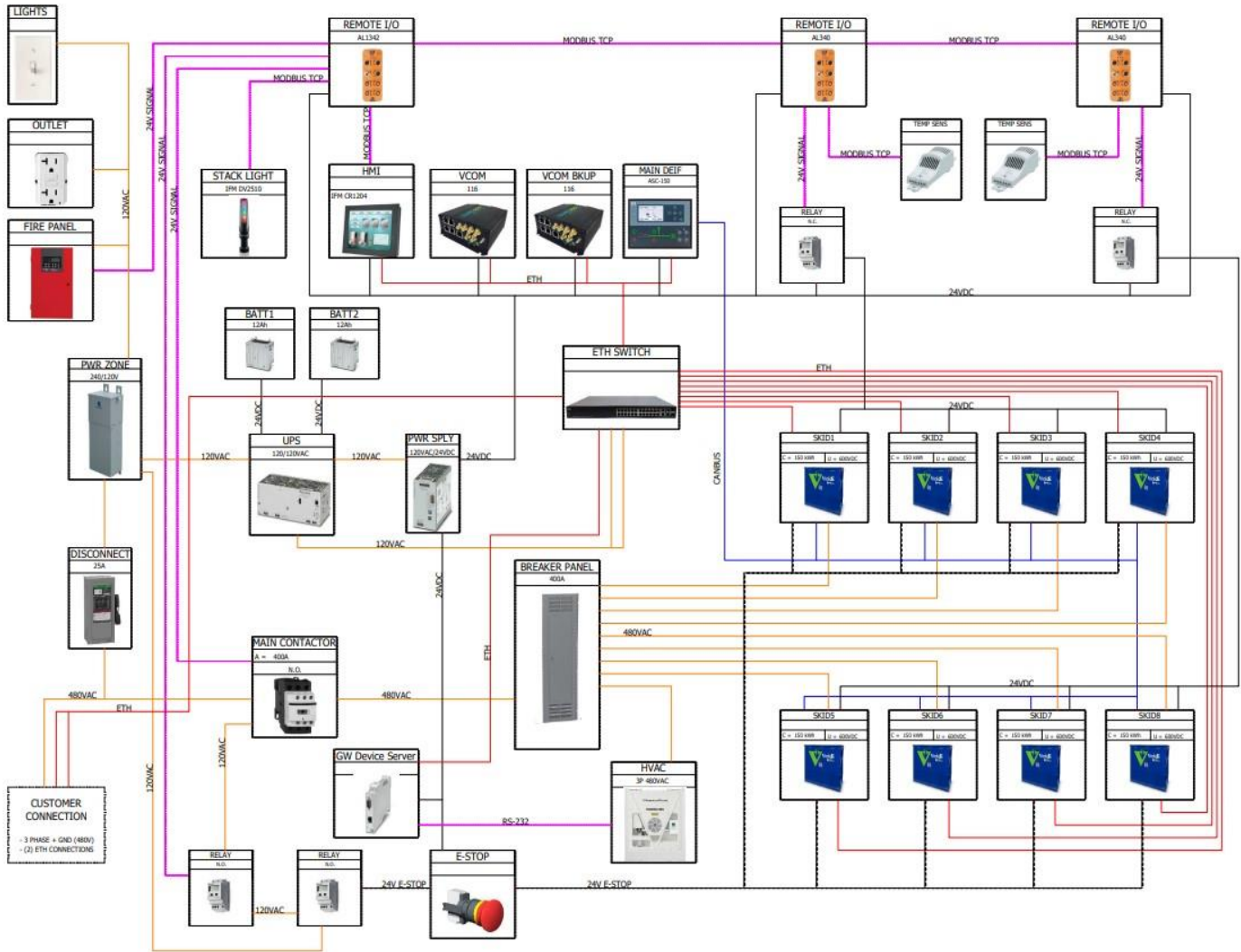

Battery Energy Storage System (BESS)

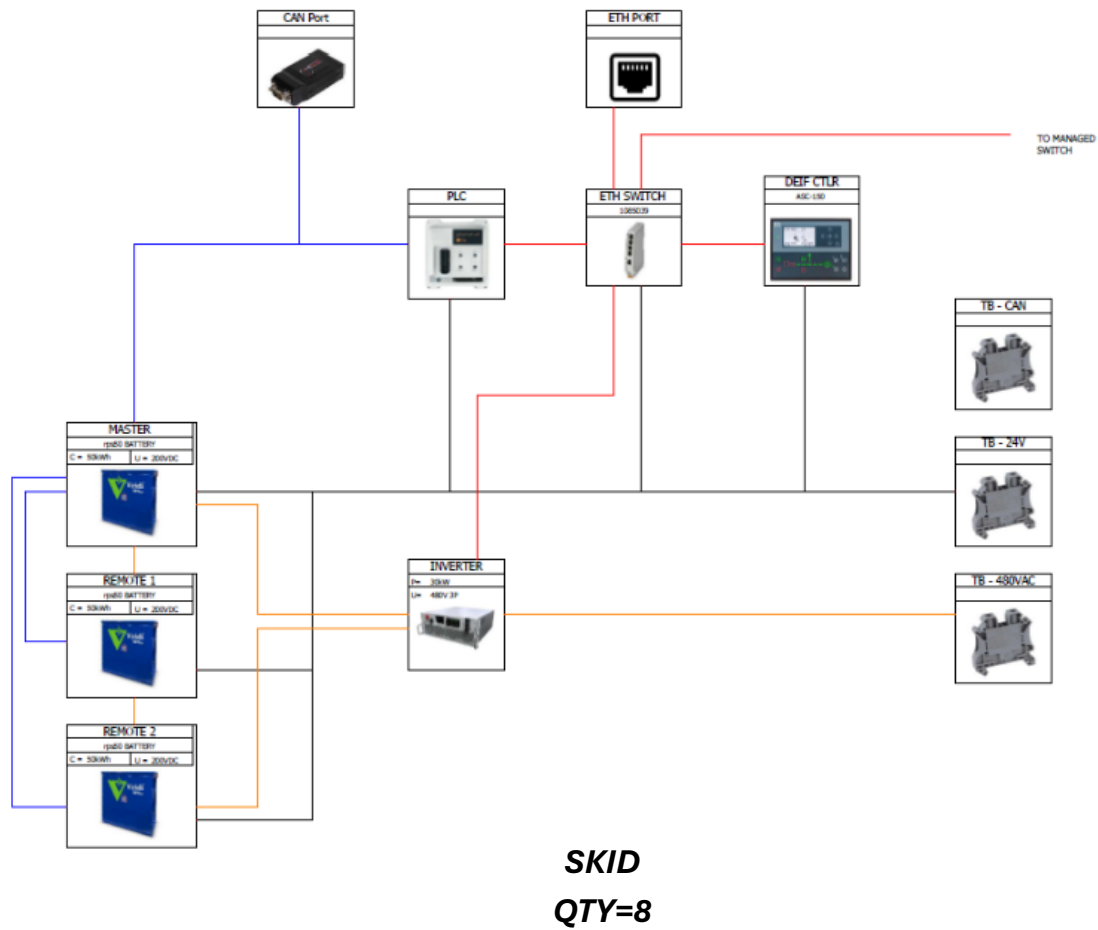

4.8 RPS1200 Certifications

- UN 38.3 (cell, module)
- UL 1642 (cell) UL Recognized Component
- UL 1741 (inverter) cTÜV SÜDus Listed
- IEEE 1547 (inverter) cTÜV SÜDus
- UL 1973 (pack) cETLus Recognized Component
- UL 2580 (cell) UL Recognized Component
- UL 9540A (cell/module/pack tested)

5. ViSTA

The RPS1200 utilizes a wireless cellular communications module to send location and usage metrics to an administrative dashboard called ViSTA. The following will provide the basics for utilizing ViSTA.

5.1 Logging In

Find an email from ViSTA notifications with a link to create a ViSTA account.

Setup a vista account by emailing Service@viridiparente.com. Once setup login by going to: <https://vista.viridiparente.com/login>.

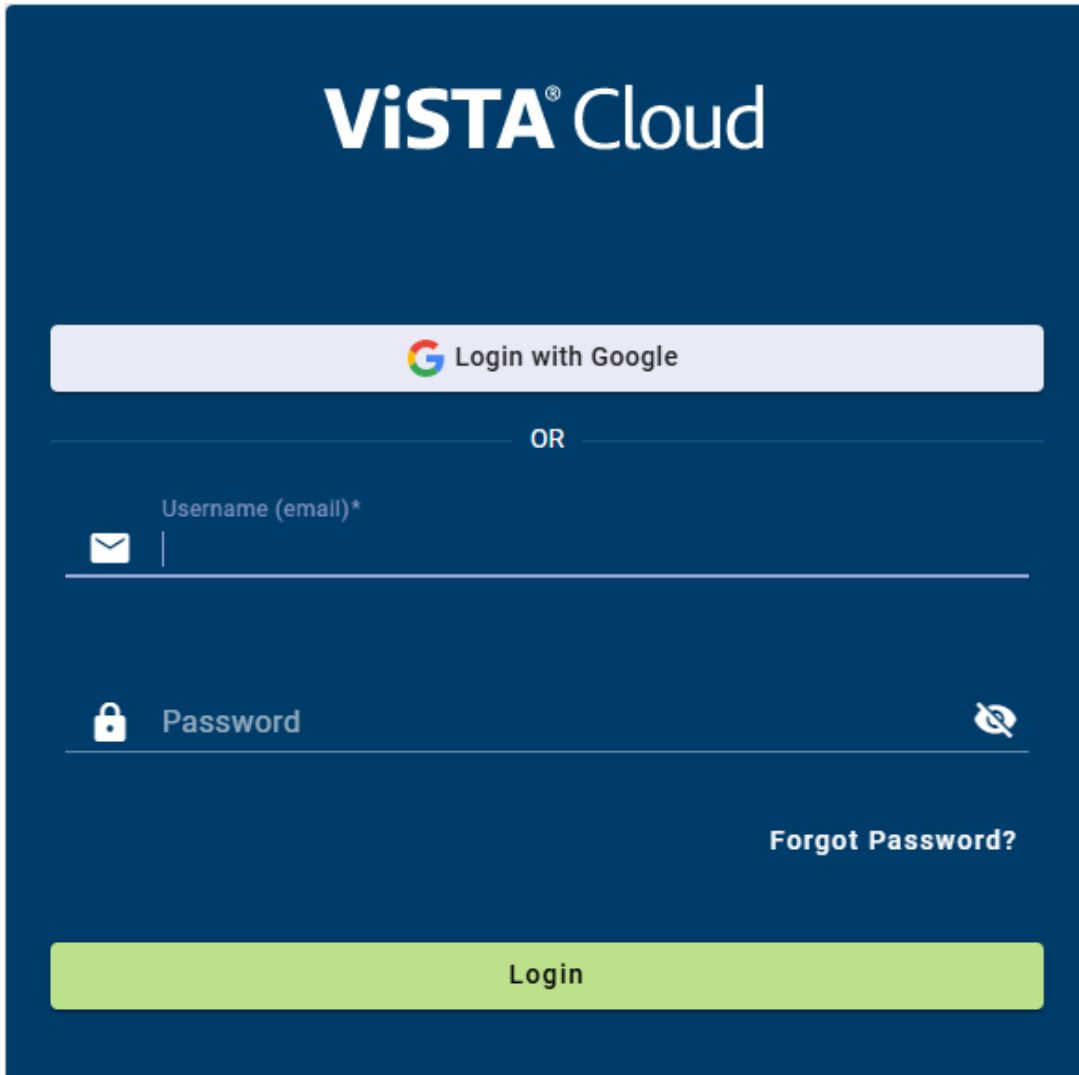

ViSTA® Cloud

Login with Google

OR

Username (email)*

Password

Forgot Password?

Login

5.2 ViSTA Dashboard

5.2.1 The Container View

This is the container view which provides an overview of the RPS1200's metrics and provides the ability to access the HMI, check alarms, and look deeper into each skid's metrics

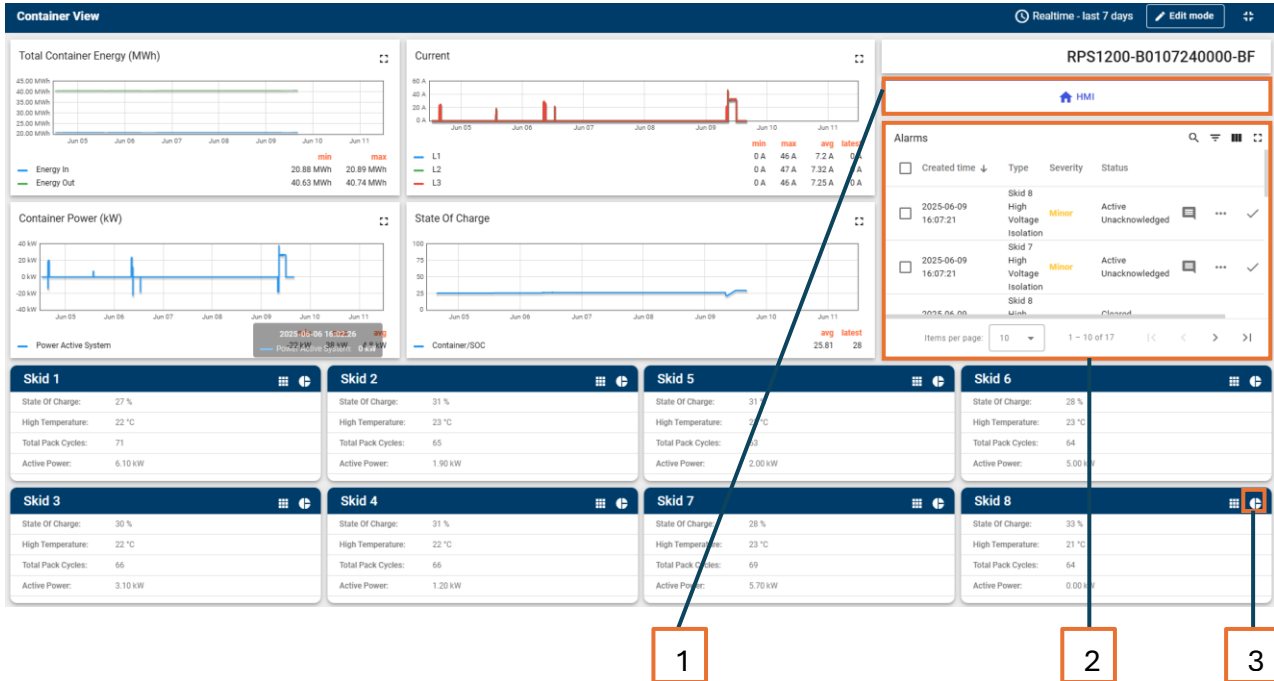

1. **HMI Button:** If the RPS1200 has Wire guard activated, clicking this button displays the HMI screen.
2. **Alarms:** These can be filtered to show any alarms notifications status and severity.
3. **Skid Details:** To view more detailed information about an individual skid, click on the pie chart icon.

5.2.2 Data Over Time



The alarms area permits viewing of active alarms, the type of alarm, the severity, and the status of the alarm on the RPS1200.

<input type="checkbox"/>	Created time ↓	Type	Severity	Status		
<input type="checkbox"/>	2025-06-09 16:07:21	Skid 8 High Voltage Isolation	Minor	Active Unacknowledged		
<input type="checkbox"/>	2025-06-09 16:07:21	Skid 7 High Voltage Isolation	Minor	Active Unacknowledged		
<input type="checkbox"/>	2025-06-09	Skid 8 High Voltage Isolation		Cleared		

Items per page: 10 1 - 10 of 17

Clicking on the box to the left of the alarm will acknowledge and/or clear the alarm.

Note: The alarm is only cleared on ViSTA, not on the RPS1200

Clicking on the word bubble icon on the right will allow a screen view to see the activity of the RPS1200 and add comments concerning the alarm.

By clicking the clock icon in the upper right-hand corner of any of the diagram or system devices screens will open a menu will allow viewing the real time activity or history of the system.

The real time tab allows to choose a period to view from the current time to however long ago it is set for.

The History tab is the same as the real-time tab except for the ability to choose a period in the past to view instead of just allowing a view of what the system is doing for an ongoing time frame. For example, the election can permit a view: a day from three weeks ago instead of the past 24 hours.

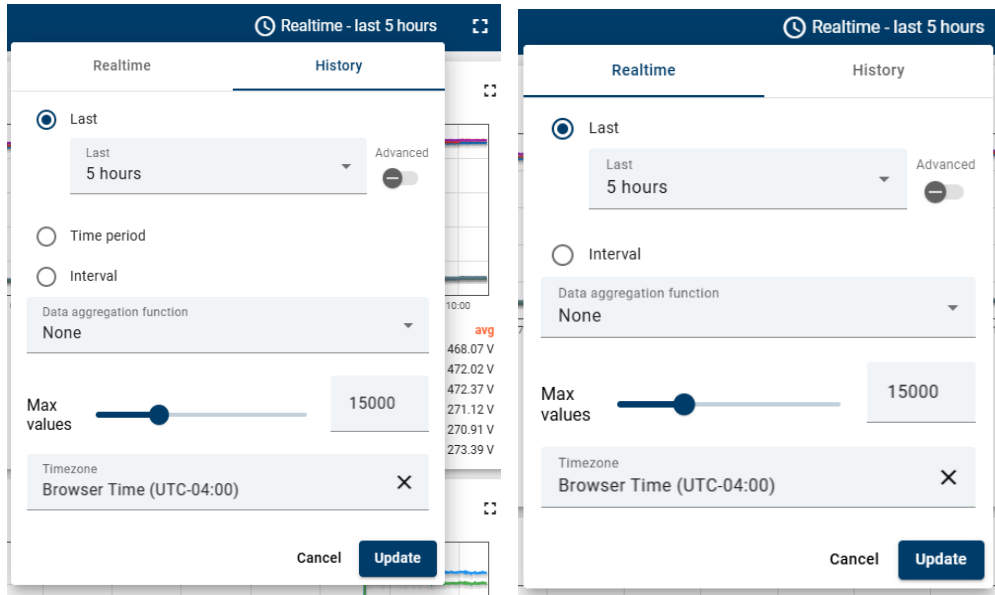

5.2.3 Fleet Dashboard

If more than one device does/will exist in the future, access to this dashboard which will allow switching between devices to access the container views

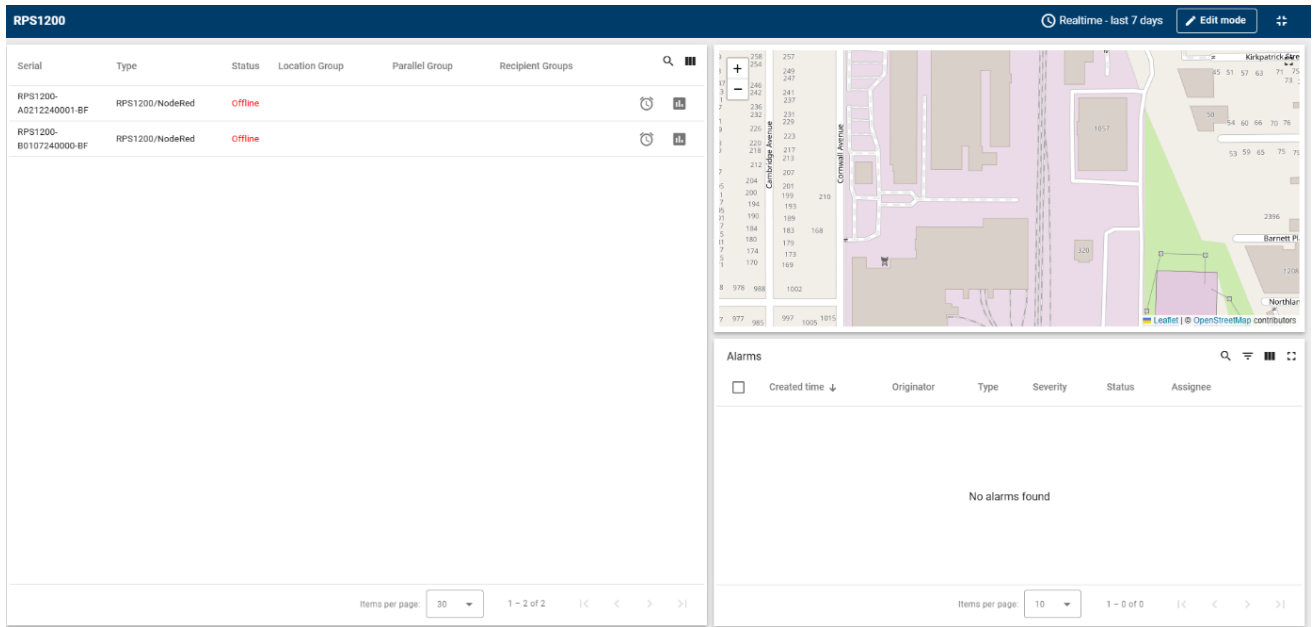

INSTALLATION



6. Installation

6.1 Location Considerations

Determine the necessary size of energy storage/back-up system for your specific application. Different project sites require different kWh of energy storage and back-up.



Submit designs and plans to appropriate authorities for review. Before beginning installation or utilization, permits and inspections must be obtained in accordance with local laws and regulations, as necessary



Coordinate RPS1200 site delivery and installation. The RPS1200 is heavy and must be installed with proper equipment. The RPS1200 must be installed according to the design plans below.

To decommission or uninstall the RPS1200, contact your Viridi service team for further instruction. This must be completed by Qualified Personnel, and any disposal of components requires compliance with local laws, rules, and regulations. Viridi encourages recycling of all materials where possible and works with American Battery Technology Company to recover lithium-ion battery components

Required equipment, tools, and other items depend on the final consumer and installation location. Consult your service engineer and local installer for further instruction.

6.2 EMI/EMC Considerations

6.2.1 Definitions

Electromagnetic interference (EMI) and electromagnetic compatibility (EMC) are both important considerations when working with electronic components. EMI is caused by electromagnetic emissions that can disrupt the function of electronic devices and radio frequency (RF) systems. These devices and systems must be properly shielded from electromagnetic radiation for them to work well. EMC measures how well these devices and systems can work in the presence of disruptive electromagnetic interference. Additionally:

- The inverter UL lists safety standards for the Inverter 1741 Supplement B and the Battery UL1973 recognition standards.
- The inverter and battery undergo EMI/EMC testing.
- The container undergoes ground bond testing to verify low chassis/earth impedance on the container.
- All communication wiring if run near high voltage AC/DC wiring is shielded to reduce the potential effect. Otherwise, is run in separate locations to remove the EMC/EMI potential on the communication lines.

6.3 Handling and Transport

General Considerations



Do not expose the RPS1200 to an open flame.



Do not place or store the RPS1200 near highly flammable materials.



Do not expose or place near water sources.



Do not install the RPS1200 in an airtight enclosure or in an area without ventilation.



Store the RPS1200 on a flat, level surface in a cool, dry location.



Do not disconnect, disassemble, or repair the RPS1200 with unqualified personnel. Only Qualified Personnel should handle, install, and service the RPS1200



Do not deform, impact, cut, or penetrate the RPS1200 with a sharp object. Doing so may cause a fire or leakage of electrolytes.



Do not step on or stand on the RPS1200 or its packaging.



Do not place any objects on top of the RPS1200.



Do not charge or discharge RPS1200 if damaged or malfunctioning.



The RPS1200 has a NEMA 3R rating, which provides protection from falling rain, dirt, and sleet and will be undamaged by the external formation of ice on the enclosure. Do not hose down the RPS1200 or pressure wash, as it is not rated for hose directed water.

Note: Lifting and unpacking guidelines will depend on the final consumer and local installation parameters. Follow established workplace safety guidelines and procedures when receiving, handling, transporting, unpacking, lifting, and installing the RPS1200.

6.4 Wiring Install Instructions

6.4.1 Punch out Necessary Hole in Customer Connection Panel

Remove customer connection panel, as pictured below. Proceed by punching out a hole of the necessary size for the grid and then re-attach customer connection panel and feed through wiring into electrical gutter through punched hole.

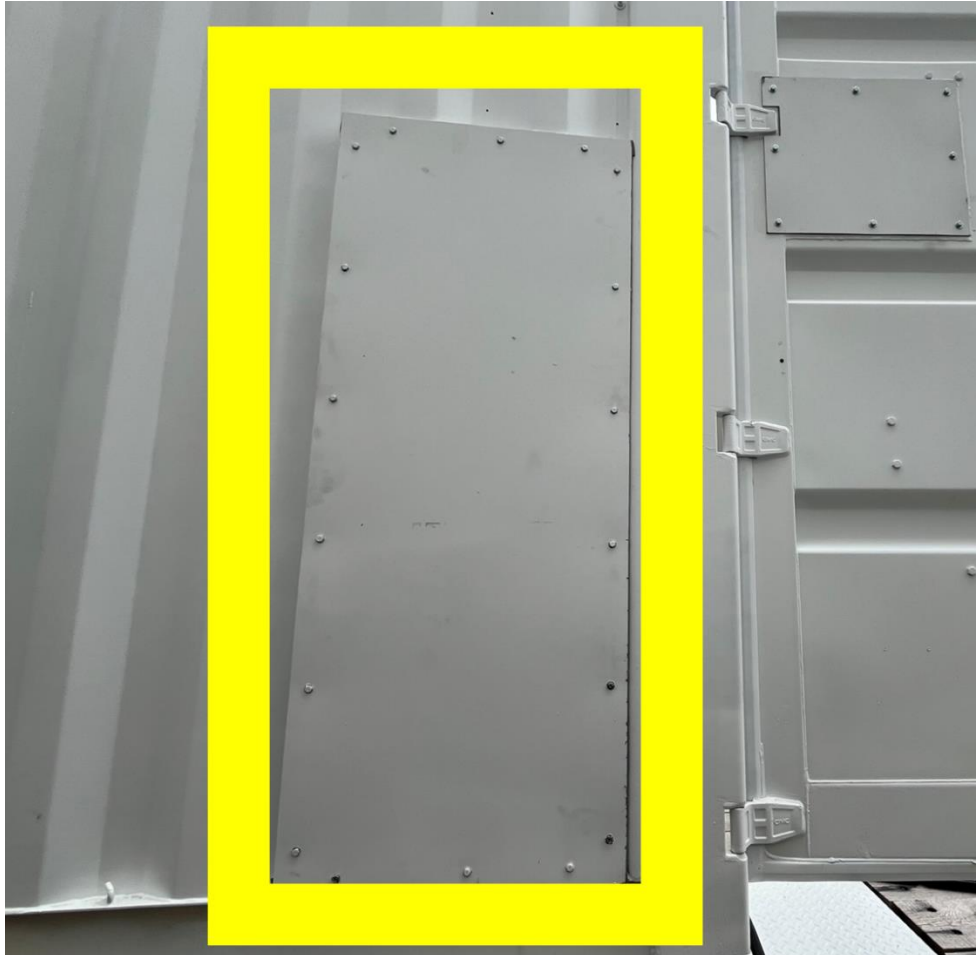

6.4.2 Open the Gutter

Using a slotted-tip ECX2 screwdriver loosen each screw on the housing of the gutter located below the fire suppression system. Then, carefully shift the panel to the left, such that the screws are in line with the holes in the panel with a larger diameter. Then remove the panel by pulling it outwards.

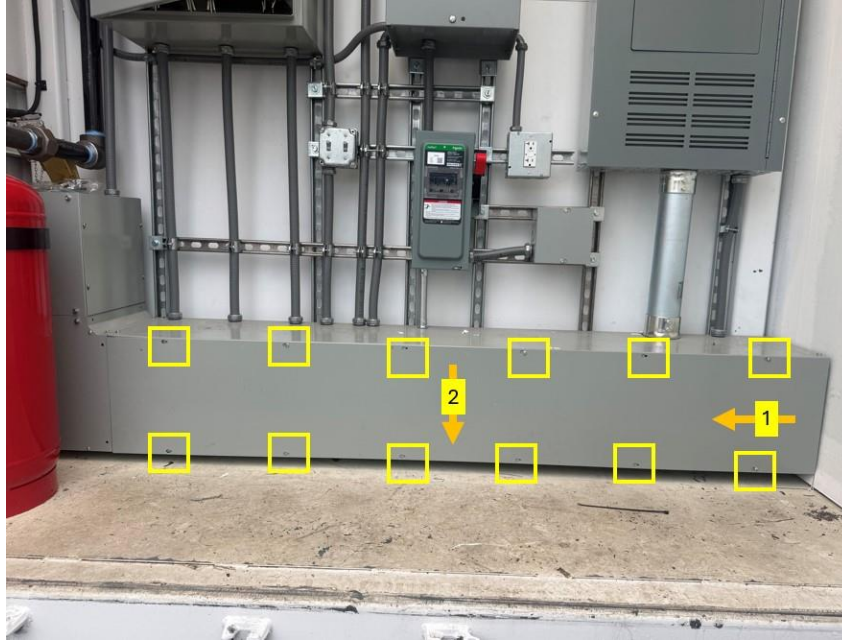

6.4.3 Locate Terminal Blocks

Inside the electrical gutter, locate the 2 sets of terminal blocks, as pictured below.

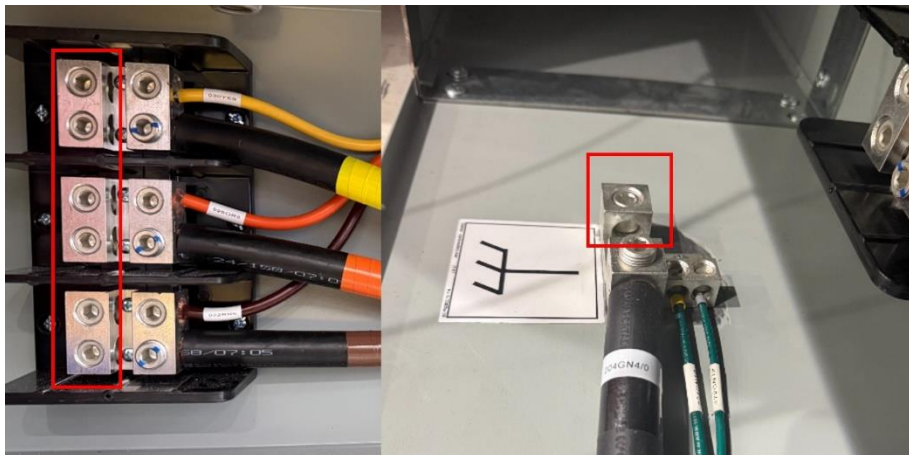

6.4.4 Connect Wires to Terminal Blocks

For each wire fed through the customer control panel, unscrew the corresponding left terminal block with a 3/8" Allen key and insert the bare wire into the gap below the screw. Refer to the torque table in section 9.1.7.1 for the proper torque specification.

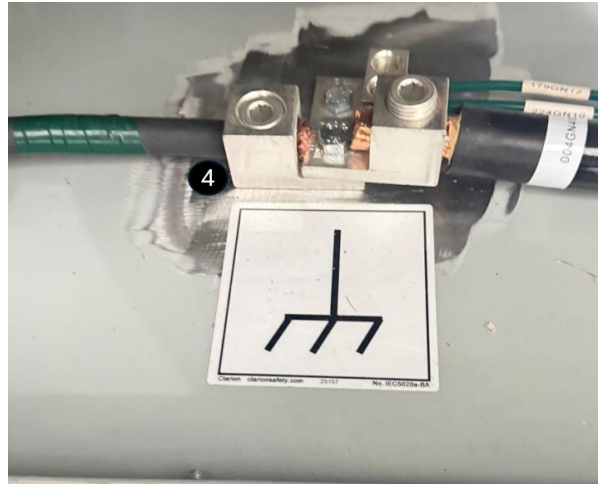
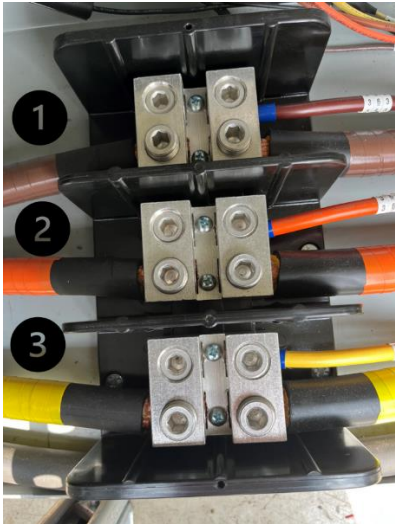

6.4.5 Reattach the Gutter Housing

Reattach the panel housing and shift the housing to the right. Using a slotted-tip ECX2 screwdriver tighten each screw on the housing of the gutter.

6.5 Commissioning

6.5.1 Introduction

Commissioning of a newly installed and existing ESS that has been retrofitted, replaced or previously decommissioned and is returned to service shall be conducted prior to the ESS being placed in service in accordance with a commissioning plan that has been approved prior to initiating commissioning.

6.5.2 RPS1200 Commissioning Checklist

Commissioning Checklist – RPS1200				
Phase	Step	Checklist Item	Status (OK / Pending / N/A)	Comments / Notes
Phase – 1 Pre-commissioning and Documentation Review	1.1	Verify design documentation set (single-line diagrams, layout, control logic, network diagram).		
	1.2	Confirm permits, interconnection approvals, and utility witness test plan readiness.		
	1.3	Review as-built wiring vs drawings; mark deviations.		
	1.4	Verify system labeling, nameplates, and warning signage.		
	1.5	Safety documentation — lockout/tagout plan, emergency response plan.		
	1.6	Confirm alarm triggers: To HMI and also to ViSTA system.		
Phase - 2 Mechanical & Installation Inspection	2.1	Check physical mounting of container is level / sufficient		
	2.2	Confirm container grounding/bonding continuity (< 10 mΩ preferred).		
	2.3	Inspect conduit entries and gland seals for water ingress protection		
	2.4	Verify presence of fire suppression and smoke detection systems.		
	2.5	Verify system is intact post shipping (loose equipment, hanging wires)		
	2.6	Complete commissioning of fire suppression system.		
Phase - 3 Electrical Verification (Before Energization)	3.1	Torque check on bus and terminal connections for utility connection (as per manufacturer specifications).		
	3.2	Ground continuity test from all frames to main earth (< 1 Ω).		
	3.3	Verify OCPD reset/close and open without issues		
	3.4	Verify auxiliary power circuits (control, UPS, Network Switch, Fire Panel).		

Commissioning Checklist – RPS1200				
Phase	Step	Checklist Item	Status (OK / Pending / N/A)	Comments / Notes
Phase - 4 Controls, Communication & Software	4.1	Power on 480VAC utility feed to the container.		
	4.2	Power up control system on auxiliary power only (no DC main contactors closed).		
	4.3	Test communication links (VCOM ↔ HMI ↔ PLC/BMS ↔ PCS).		
	4.4	Verify alarms and event logging functions.		
	4.5	Verify functionality of Thermo King		
Phase - 5 Functional / Dry Run Tests	5.1	Close main contactors under electrical contractor or engineering supervision (initial DC energization).		
	5.2	Run charge/discharge command tests at low power (< 10%).		
	5.3	Verify SOC reporting accuracy, voltage/current sensor calibration.		
	5.4	Confirm alarm triggers: To HMI and to ViSTA system.		
	5.5	Test emergency stop and system safe shutdown sequence.		
	5.6	Verify RPS1200 is visible and active on ViSTA Monitoring Platform		
Phase - 6 Performance / Integration Tests	6.1	Power/energy capacity test (compared to nameplate). ▶ Refer to Project Scope of Work document to validate if required"		
	6.2	Efficiency test (charge/discharge round-trip). ▶ Refer to Project Scope of Work document to validate if required		
	6.3	Communications with site EMS/SCADA verified live. ▶ If EMS Present, Refer to Project Scope of Work document		
	6.4	PV Zero Export - Verify that PV Zero Export algorithm and BESS setpoints are properly set and maximize solar self-consumption ▶ EMS Must be Present, refer to Project Scope of Work document to validate if required		
	6.5	Peak Shaving - Verify that BESS setpoint is properly set and limiting building kW peak to lower utility demand cost. ▶ EMS Must be Present, refer to Project Scope of Work document to validate if required		

Commissioning Checklist – RPS1200				
Phase	Step	Checklist Item	Status (OK / Pending / N/A)	Comments / Notes
	6.6	Load Shift - Verify that BESS setpoint is properly set and limits building kWh energy consumption during utility on-peak hours. ▶ EMS Must be Present, refer to Project Scope of Work document to validate if required		
Phase 7 Safety & Protection Validation	7.1	Test fire suppression activation/communication (simulation of trigger call to either Building management system or Fire Department). Activate Monitoring account, if required		
	7.2	Validate interlocks between PCS, HVAC, and fire system.		
	7.3	Confirm fail-safe logic under communication loss.		
	7.4	Confirm data logging for safety events.		
Phase 8 Final Acceptance & Documentation	8.1	Collect test data, sign-off sheets, torque records, calibration certificates.		
	8.2	Train operations personnel on normal and emergency procedures.		
	8.3	Submit commissioning report and punch-list closure.		
	8.4	Provide as-built drawings and configuration backups as required.		
	8.5	Transition to warranty/start of service period.		

OPERATION



7. Startup

7.1 RPS1200 General Startup Instructions

Steps 7.1.1 thru 7.1.5 apply to all RPS1200 applications – at which point see relevant section detailing specific startup steps to put RPS1200 into various operational modes.

7.1.1 Access the Front User Interface (UI) Panel

Using a flathead screwdriver, carefully open the front user interface panel (the panel where the user interface screen is mounted).



7.1.2 Ensure All Breakers and Disconnects Are in the ON Position

Ensure that all circuit breakers and disconnect switches are in the “ON” position before proceeding, if not switch all 3 breakers inside the panel up into the “ON” position.

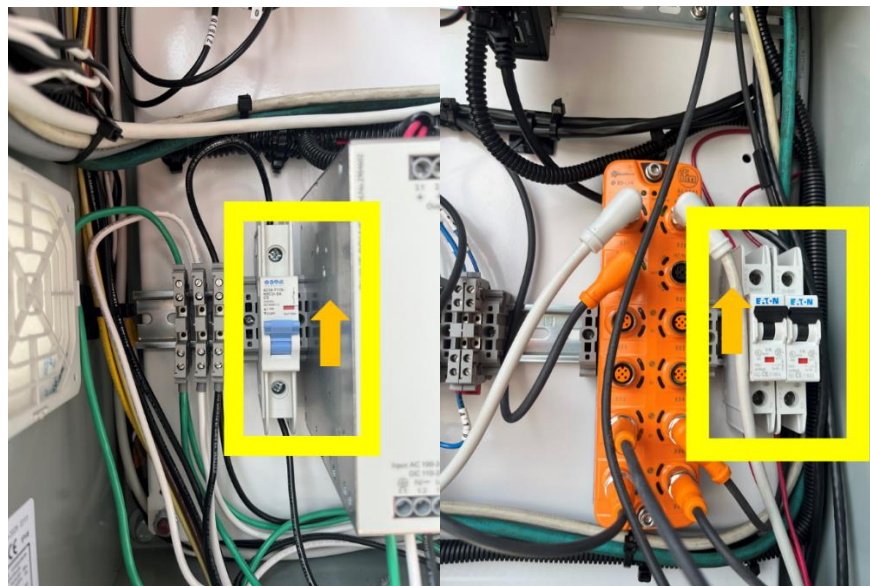

7.1.3 Engage the UPS Start Switch

Turn the UPS start switch, located on the right side of the front user interface panel, clockwise (to the right) to initiate the low voltage system.

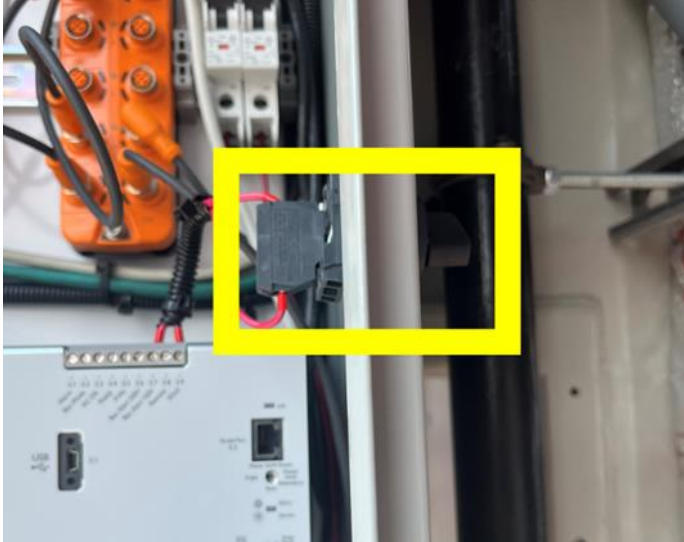

7.1.4 Confirm Low Voltage Power Activation

The 24V and 120V power systems should now begin to power up. To confirm, listen for the Cisco networking switch’s boot-up sound, and confirm that its LEDs illuminate.

7.1.5 Verify and Wait for Battery Communication on User Interface

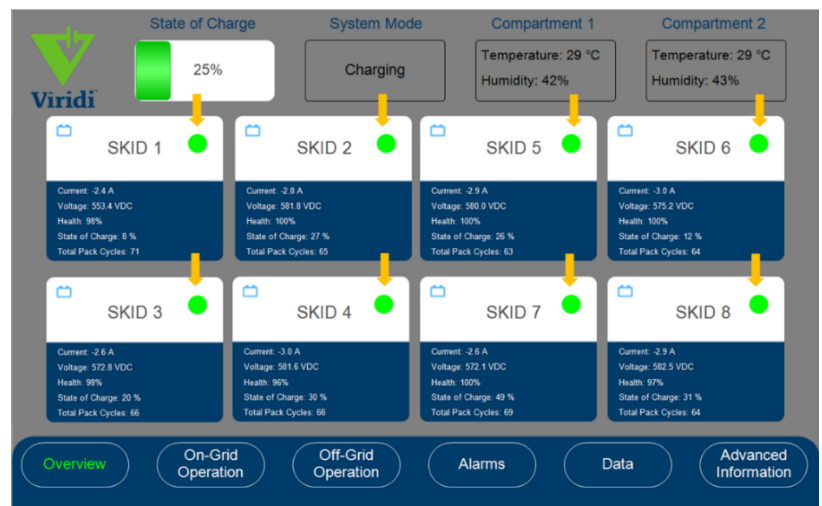

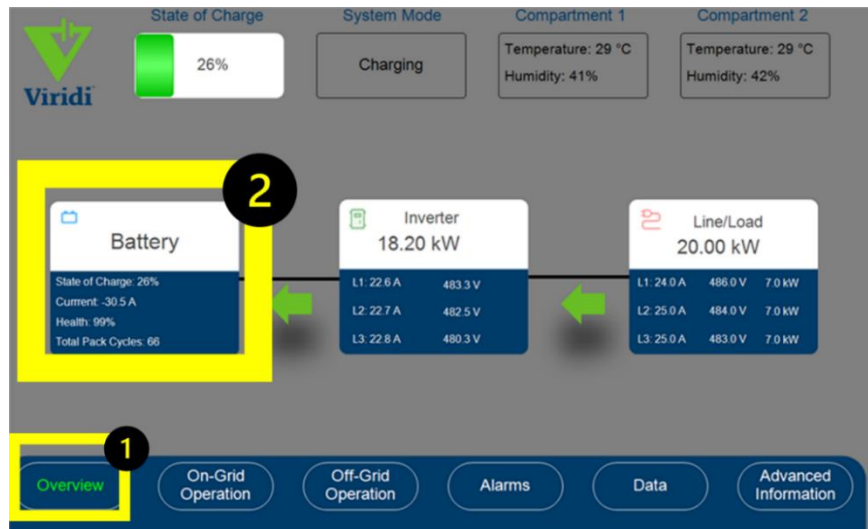

Once the system has booted, navigate to the User Interface Screen. Select **“Overview”** at the bottom of the screen, then select **“Battery”**. On the battery overview screen, verify that all 8 batteries display a green indicator in the top-right corner, signifying active communication with the PLC. A red indicator denotes no communication. The system will take 5-10 minutes to fully initialize, wait for the according time until the green indicators to appear.

If configuring the system in Off-Grid mode, please follow the steps in the “Off-Grid” Startup Section.

7.2 RPS1200 Off-Grid Startup Instructions

7.2.1 Enter Off-Grid Standby Mode

Select the **“Off-Grid”** section and select **“Off-Grid Standby”** mode.

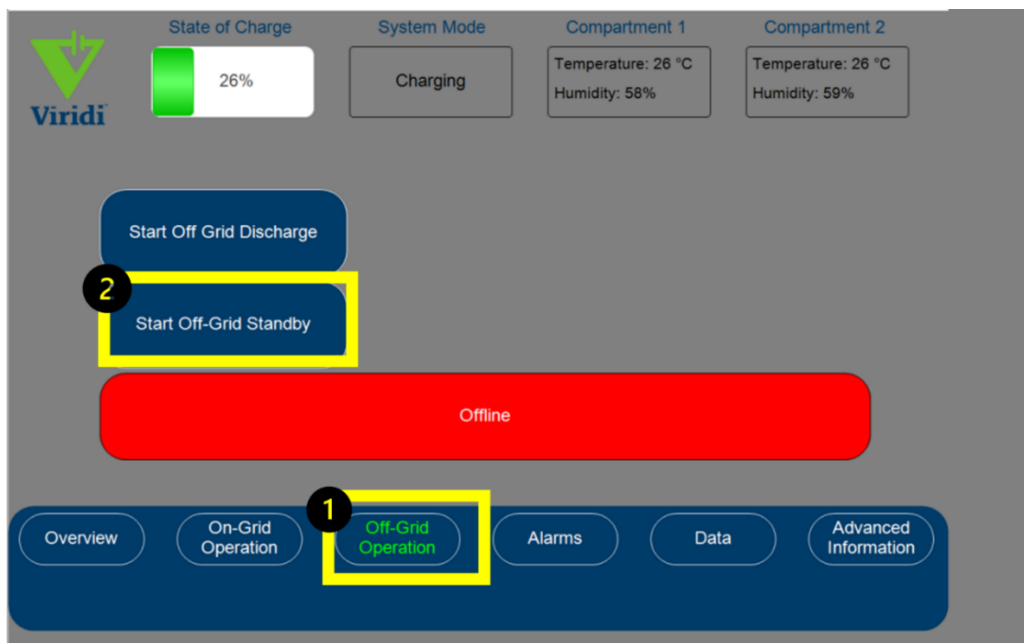

7.2.2 Verify Inverter Initialization

The main contactor engaging should be heard, followed by the inverters powering on. To confirm this, return to the “Overview” tab and select “Inverters”. All 8 inverters should illuminate green. If not, allow additional time for each inverter to initialize sequentially.

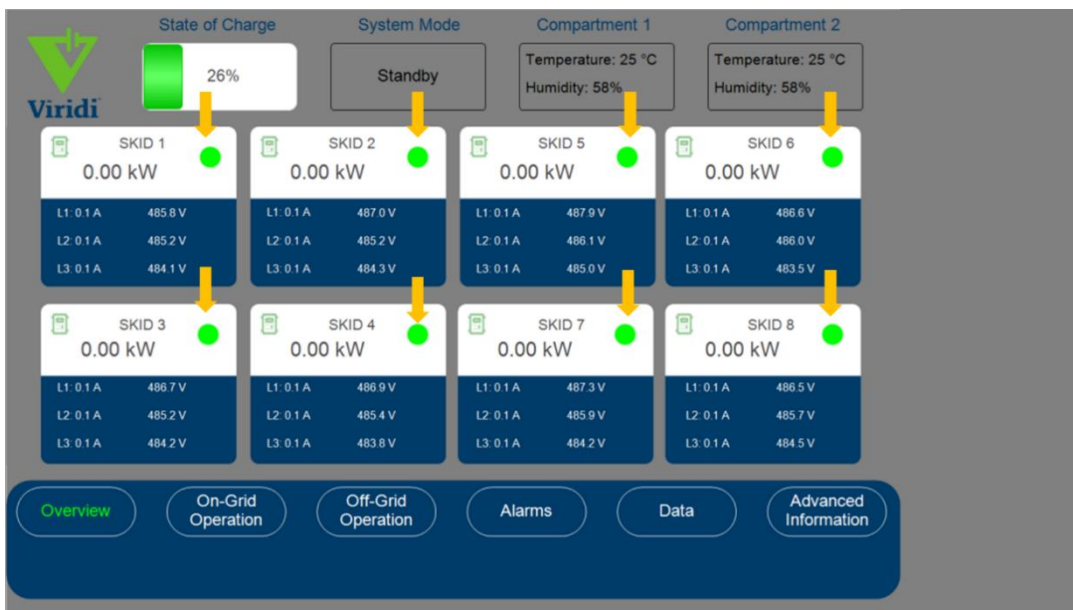
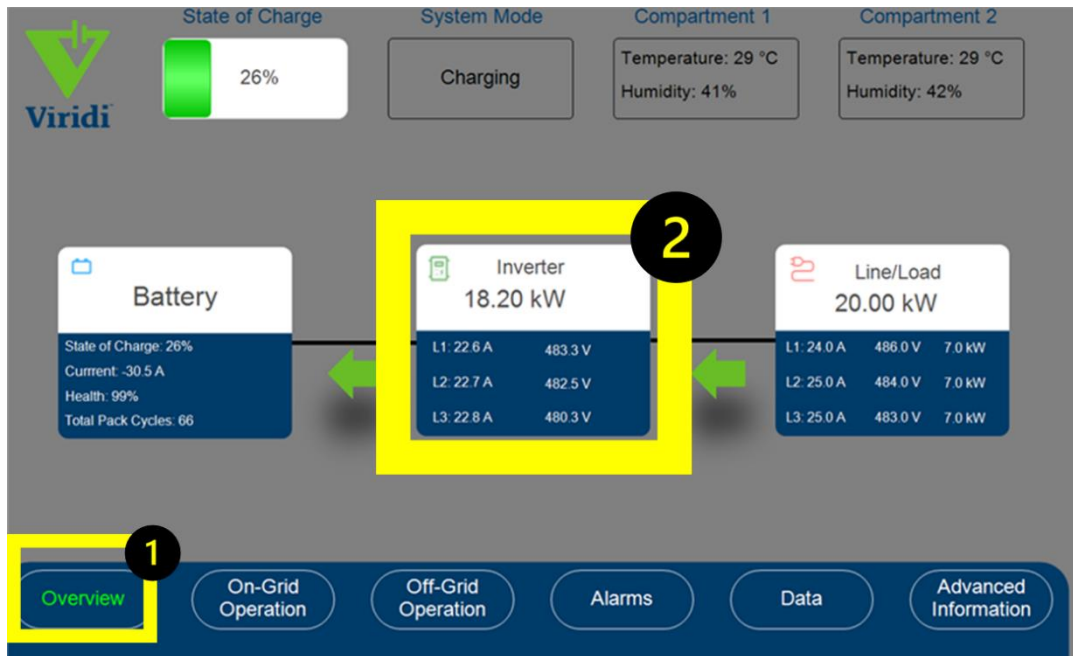

7.2.3 Start Off-Grid Discharge Mode

Once all inverters are online, select “Start Off-Grid Discharge”.

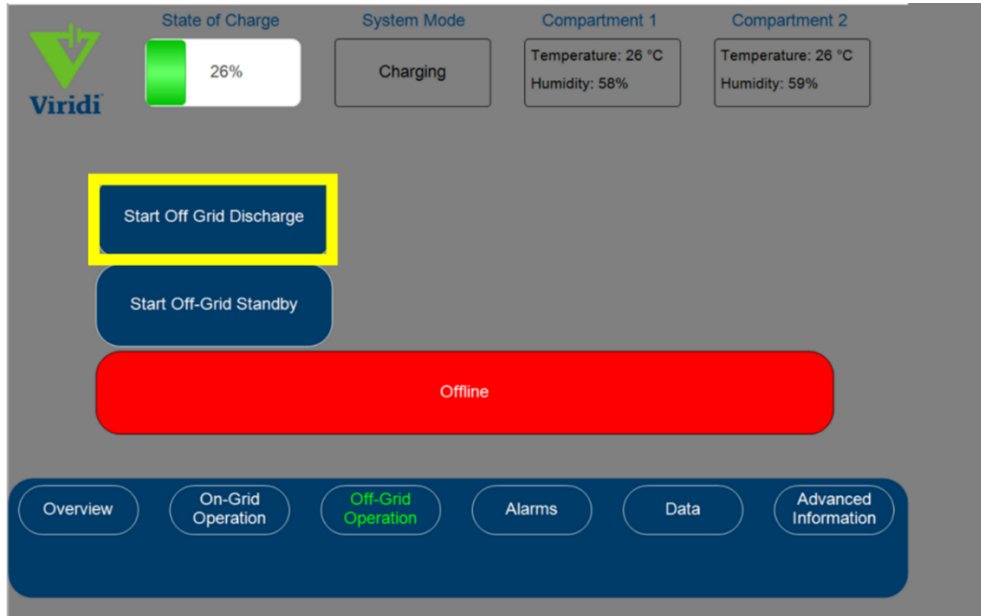

7.2.4 Confirm Inverters are Engaged and Power Output

The inverters will begin engaging one by one. Confirm this by reselecting “Overview”, then the “Battery” and by confirming that each inverter reads nonzero active power (kW). All inverters should now be actively discharging and supporting the system load.

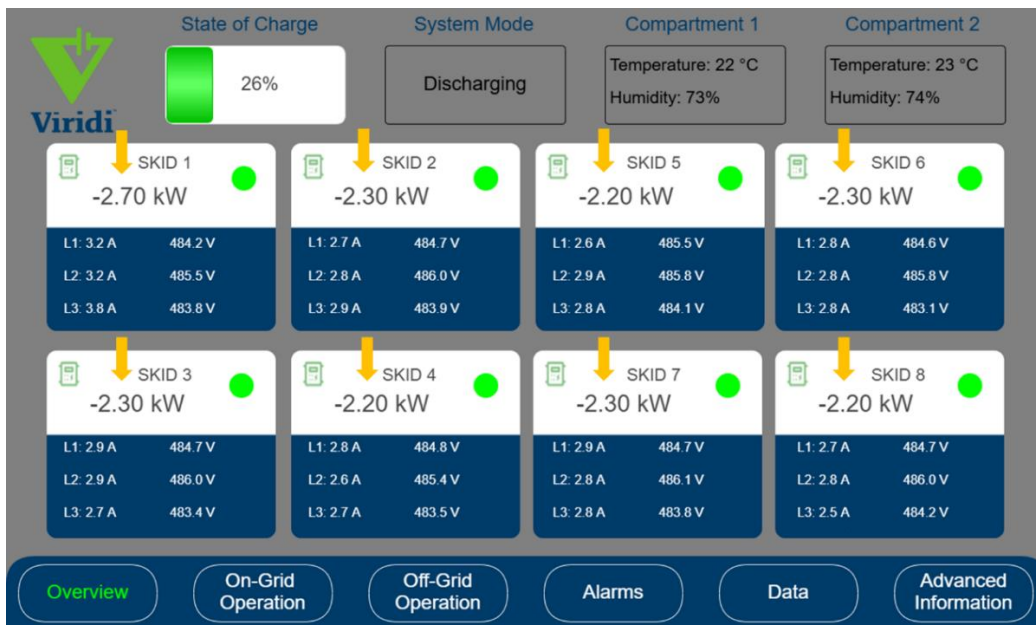

7.3 RPS1200 On-Grid Startup Instructions

7.3.1 Enter On-Grid mode and Start Standby

Enter On-Grid mode by selecting “On-Grid Operation” on the bottom of the User Interface screen. Then select “Start Standby”.

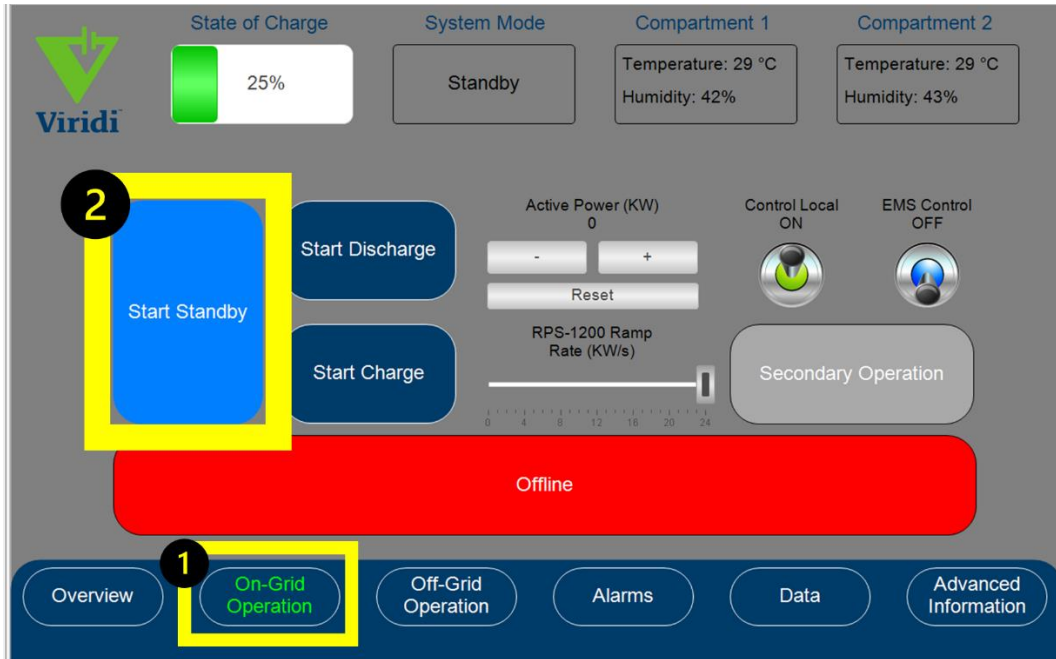

7.3.2 Verify Inverter Initialization

The main contactor should be heard when it is engaged, followed by the inverters powering on. To confirm this, return to the “Overview” tab and select “Inverters”. All 8 inverters should illuminate green. If not, allow additional time for each inverter to initialize sequentially.

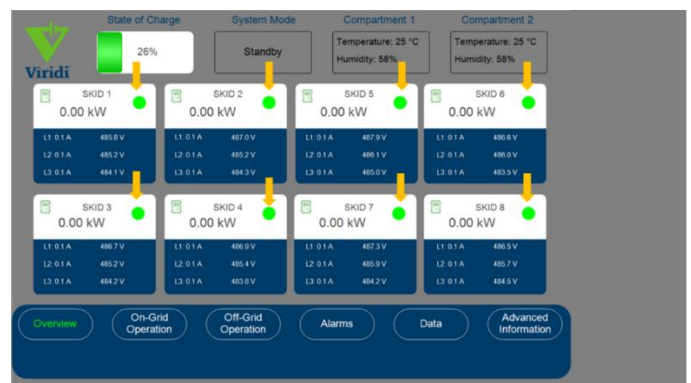
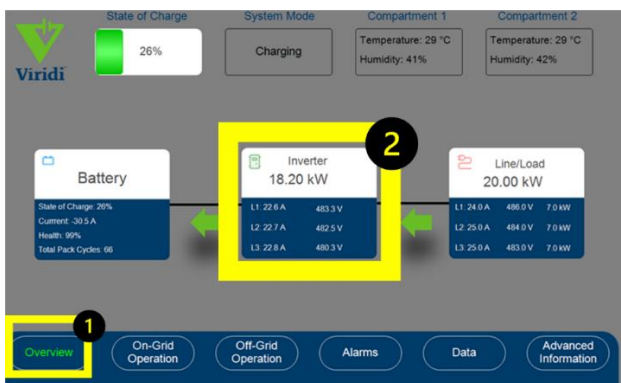

7.3.3 Start On-Grid Discharge Mode

Once all inverters are online, select “Start Discharge” or “Start Charge”.

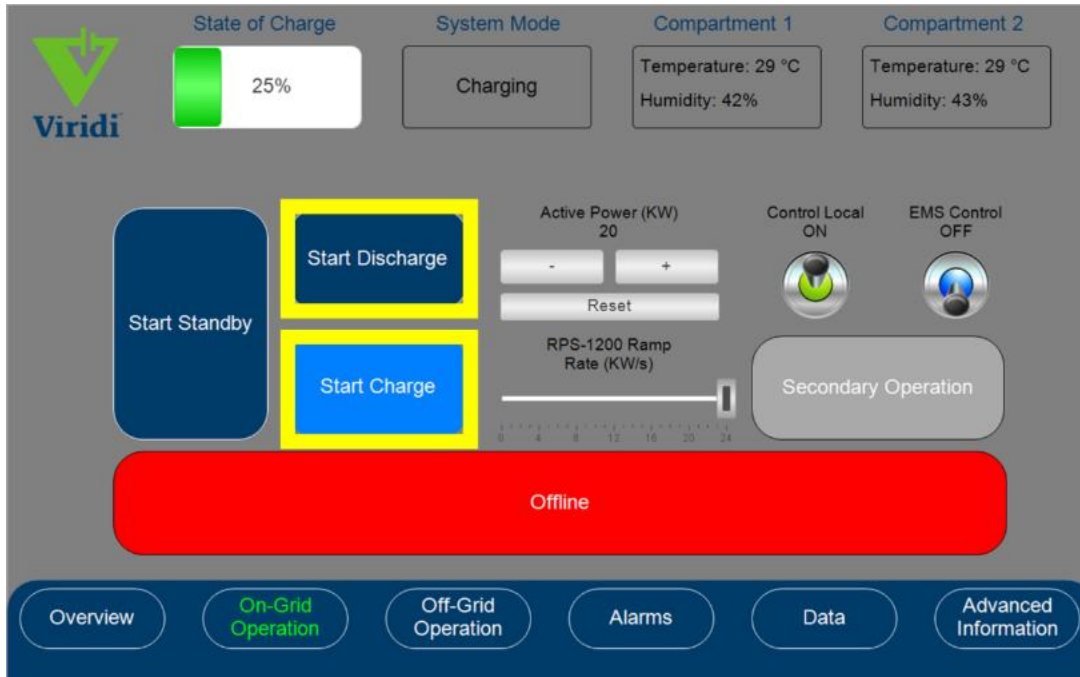

7.3.4 Confirm Inverters are Engaged and Power Output

The inverters will begin engaging one by one. Confirm this by reselecting “Overview”, then the “Battery” and by confirming that each inverter reads nonzero active power (kW). All inverters should now be actively discharging and supporting the system load.

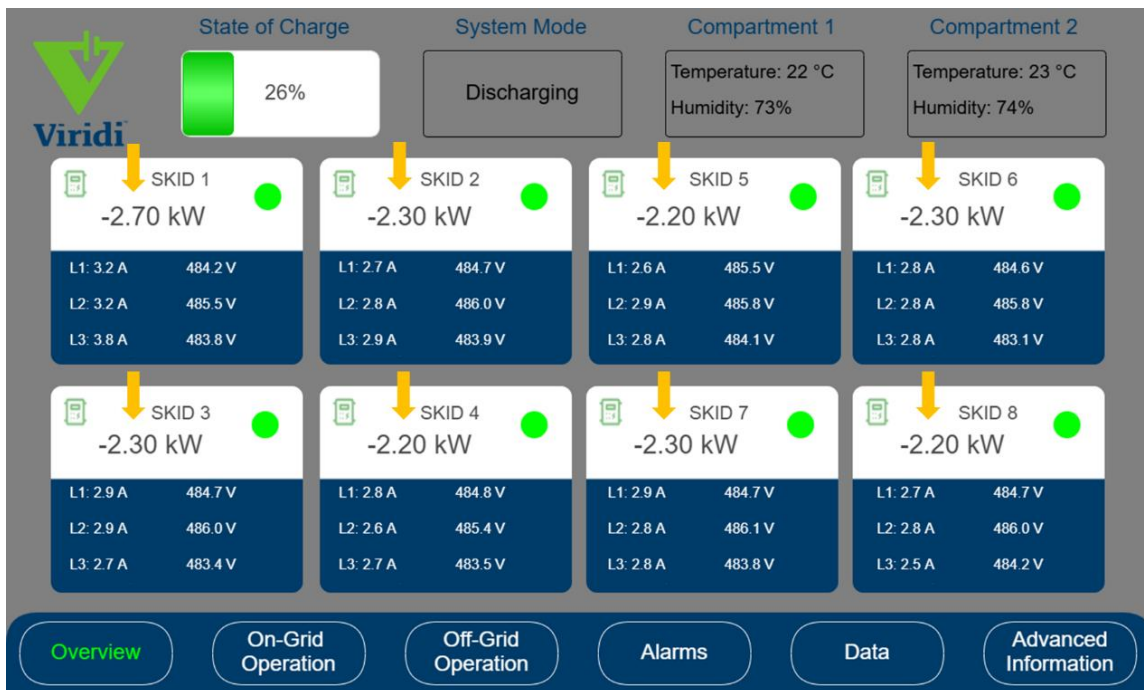

7.4 RPS1200 EMS Startup Instructions

- On System display, select overview” on the bottom task bar.
- Put unit into “On-Grid Standby”
- Enable “Control local” switch.
- Select “EMS control” switch.

***NOTE:** Once the system is started and EMS is activated, no other setting changes are needed. All will be handled via EMS. You should see the unit hop into Charge or Discharge mode under “On-Grid Operation”

7.5 RPS1200 Startup Procedure for other modes

1. On System display, select “On-Grid Operation” from the bottom task bar then select “Start Standby”. Wait for all inverters to boot. Then select “Secondary Operation”.
2. Enable desired mode:
 - Time of Day Cycling: Lets the user control Time of day setpoints, active power, as well as the SOC range of the battery. Will cycle the battery between the TOD setpoints.
 - Cycling Settings: Lets the user control active power setpoints under secondary operation. Will cycle between cell voltage ranges.
 - Manual Operation (Main screen under the On-Grid taskbar, no need to go to secondary operation): Lets user control active power setpoint: Will stay at that active power setpoint until changed.
 - Skid balancing: Is when the container charges to the highest skid level SOC value. Ex. When the unit is placed into this mode and the highest SOC skid value is 80, then all skids will charge to 80 via the charge power setpoint under “Secondary Operation”.
 - Select “Overview” in the bottom task bar.
3. ***NOTE:** System will now boot to user desired mode and setpoints.
4. Upon successful startup verify the following:
 - Grid voltage is within the expected range of utility.
 - No faults are present on the system display.
 - All systems are running, and the unit is operating as expected.

8. SHUT DOWN

8.1 RPS1200 Shutdown Instructions

The following instructions are identical for both On-grid and Off-grid operation.

8.1.1 Navigate to the User Interface Screen

Inside the door of the RPS1200 Container, the User Interface Screen, pictured below.



8.1.2 Turn Off the System

Select “Off Grid Operation” and then select “Offline” on the User Interface Screen.



8.1.3 Access the Front User Interface (UI) Panel

Using a flathead screwdriver, carefully open the front user interface panel (the panel where the User Interface screen is mounted).



8.1.4 System Power Down

Ensure that all circuit breakers and disconnect switches are in the “OFF” position. Turn off the Uninterruptible Power Supply and low power system. If not switch all 3 breakers inside the panel down onto the “OFF” position.

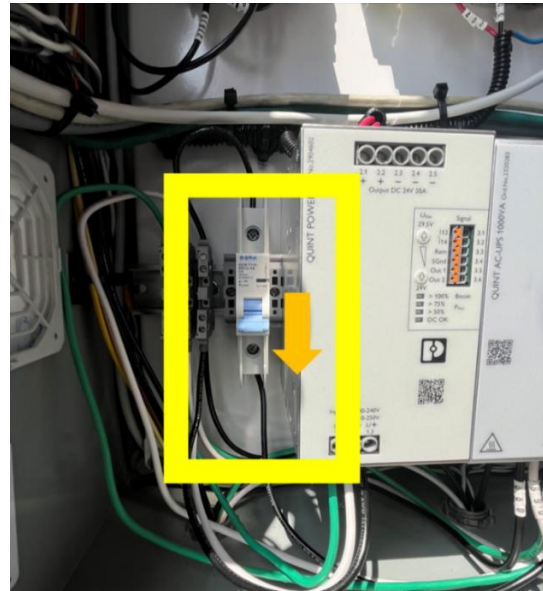
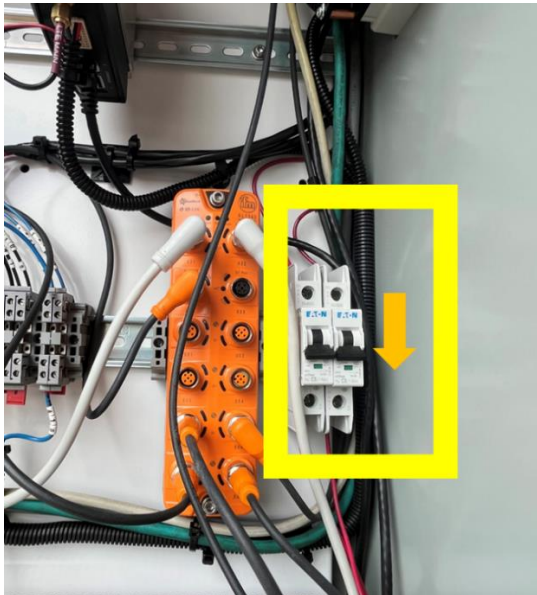

8.1.5 Ensure UPS power switch is OFF

Turn the UPS start switch, located on the right side of the front UI panel clockwise (to the right) to initiate the low voltage system.



MAINTENANCE



9. Maintenance

Note:

- (1) Personnel performing maintenance on the RPS1200 must be trained and familiar with the operation and configuration of the RPS1200.
- (2) The BESS must be completely disconnected (external power source in a deenergized state with proper Lock Out – Tag Out [LOTO] devices installed) for all external connections and interfaces prior to any type of maintenance operation.
- (3) Clearing and Cleaning - After installation and commissioning, regularly clean, check ventilation and air exhaust devices. Periodic cleaning is recommended, to start (based on environmental characteristics) a three-month schedule is recommended. After installation and commissioning, regular fan, filters and inspection time and systems checks may be extended at customer discretion.
- (4) If torquing of fitting and/or connections are required, verify the torque wrench has a current calibration sticker.
- (5) If any maintenance is performed that involves disturbing electrical connections, ensure that connections are re-torqued to specification afterwards.

9.1 Periodic Scheduled Maintenance

The following is a recommended scheduled maintenance check/verification for the internal/external components of the RPS1200

Task List <i>(see 9.1.1 thru 9.1.9 below for item locations and detail)</i>	Commissioning	Monthly	Quarterly	Semi-Annually	Annually	As Indicated
9.1.1 AFP Fire Suppression System – Inspection by certified fire inspector	X					X
9.1.2 Thermo King HVAC Visual outside inspection	X	X				
9.1.2 Thermo King HVAC - Preventative Maintenance Check						X
9.1.3 Sinexcel Inverters - Vacuum all dust and debris from the unit			X			
9.1.3 Sinexcel Inverters - Using low pressure compressed air source, blow air through the mesh and fans			X			
9.1.4 Control Box and Enclosure - General inspection inside of the enclosure for contaminants and/or dust	X			X		
9.1.4 Control Box and Enclosure – preventative maintenance check for intake/exhaust filter and exhaust fan					X	
9.1.5 General Electrical and Bolt interface connections - Check for oil, dust, oxidation, and contaminant accumulation	X				X	
9.1.6 Energy Management System Cabinet <i>(optional accessory external to RPS1200 container)</i> - Check for oil, dust, oxidation, and contaminants accumulating inside of the cabinet	X				X	
9.1.7 Torque Checks – Perform thermal check OR visual torque mark check OR torque value check	X					X
9.1.8 Water Intrusion – Visual inspection for water intrusion throughout the unit	X				X	

9.1.1 American Fire Protection (AFP) Fire System

The inspection of the fire suppression system requires a certified fire inspector to perform necessary checks and maintenance. The certification shall include (but is not limited to) working with Flouro-K agents as required by the NFPA Fire Code. Work with AFP to determine maintenance schedule.

9.1.2 Thermo King Heating, Ventilating and Air Conditioning (HVAC) Inspection

The RPS1200 has (1) Thermo King Heating, Ventilation and Air Conditioning (HVAC) unit installed to keep the system cool in warm environments. This unit requires periodic maintenance to ensure it is performing optimally. Please reference the Thermo King User's Application Guide and Technical Product Overview to ensure proper maintenance and care is taken for the units.

Major inspections, maintenance and return to service shall be performed by a qualified Thermo King maintenance/service technician in accordance with the Thermo King Maintenance manual (P/N: TK 61888-4-MM-EN). It is recommended however that the following are implemented:

- Visual check of wire mesh outside HVAC unit. Ensure no breach of wire mesh or outside debris are clogging wire mesh preventing airflow into HVAC area. Remove debris from wire mesh.

If questions arise regarding HVAC, contact Thermo King Technical Service [24 / 7] at: 1-888-887-2202

If questions arise regarding the HVAC function with the RPS1200, contact Viridi customer service.

- You can access the guide at the following web address:
<https://www.thermoking.com/na/en/search/manuals.html?&referrerPageUrl=https://www.thermoking.com/na/en.html>
- HVAC units are Thermo King part number TK 61888. Reference this part number when requesting parts or assistance from Thermo King.

9.1.3 Removal / Replace of HVAC Rodent Guard

- To remove:
 - Remove the (6) M8 bolts in the locations shown in red below.
 - Pull the mesh guard frame away from the unit and set to the side
- To re-install:
 - Using the guide pins shown in BLUE, align the mesh guard frame back onto the unit.
 - Ensure that the bolts have anti-seize on them to prevent galling and seizing the bolts. If the anti-seize has dried or washed off, apply more anti-seize before re-installing
 - Torque the bolts to 19Nm

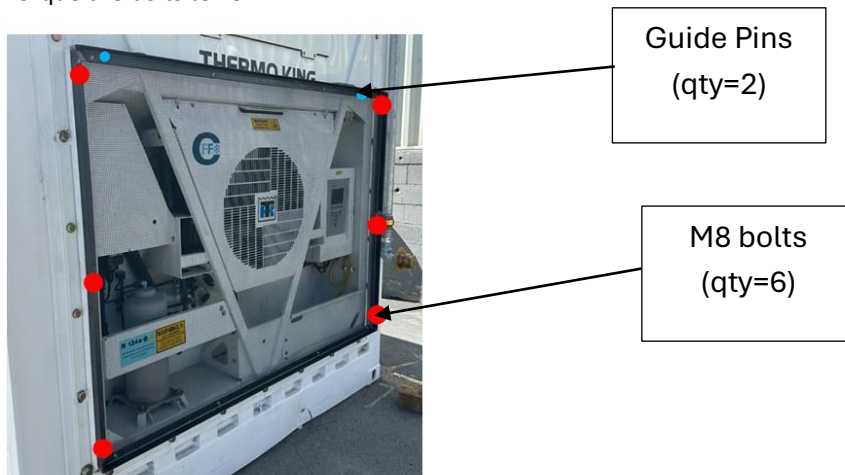

9.1.4 Sinexcel Inverter

General inspection of the Sinexcel inverters, mounting and electrical connections in accordance with the Sinexcel Operations manual (P/N: PWS2-30P-NA). General maintenance shall include but not be limited to:

- Vacuum all dust and debris from the unit
- Using a low pressure compressed air source, blow air through the mesh and fans

Note that the Sinexcel manual suggests quarterly general maintenance but based on the container being sealed and well-ventilated these can be reduced to annual checks, so long as the container doors are not left open for extended periods of time.

9.1.4 Control Box and Enclosure

General inspection inside of the enclosure for contaminants and/or dust. Intake filter and exhaust fan cleaned by specification sheet. General maintenance shall include but not be limited to:

- Exhaust Fan (P/N: 2410-00039, MFG P/N: HF0424414)
- Intake Filter (P/N: 2410-00040, MFG P/N: HG0400404)
- Clean inside of cabinet with low pressure compressed air, visually inspect fan blades.

9.1.5 General Electrical and Bolt Interface Connections

Check for oil, dust, oxidation, and contaminants accumulating on or around electrical components

- If oil, dust or contaminants are found on or around electrical components, use low pressure air and a clean microfiber cloth to clean connections
- If oxidation is found on or around electrical components, contact Viridi customer service for oxidation removal procedure.

9.1.6 Energy Management System (EMS) Cabinet(s)

Energy Management System (EMS) is an optional cabinet or cabinets external to the RPS1200 container itself

Check for oil, dust, and contaminants accumulating inside of the cabinet

- If oil, dust or contaminants are found on or around electrical components, use low pressure air and a clean microfiber cloth to clean connections
- If oxidation is found on or around electrical components, contact Viridi customer service for oxidation removal procedure.

9.1.7 Torque Check

Check proper torque for all identified electrical connections. Torque checks can be performed by thermal imaging OR torque mark visual OR torque value checks.

- **Thermal Imaging Check** – perform thermal imaging procedure with unit in operation. Compare with the thermal imaging control provided by Viridi to determine hot spots. If hot spots are located, check torque with proper torque wrench after following disconnect and LOTO procedures. Note: Thermal imaging procedure and control may not be available initially. Viridi to provide information once procedure and control are established.
- **Torque Mark Visual Check** – Any fasteners that have a clear torque mark indicator (paint pen running across fastener head onto electrical component) can be visually inspected to ensure there is no break in the torque mark indicator between the fastener and component. Note: not all fasteners will have torque mark indicators and will need to be checked with thermal imaging or torque value checks.

- **Torque Value Check** – Use a calibrated torque wrench to manually check each electrical connection’s torque value in accordance with the torque values provided in the table below and the corresponding figures/locations

9.1.7.1 Torque Check Table

Component	[Location(s)]	Torque Value [Nm]	Frequency
Main Contactor	[A]	A – 35Nm	Annually
Customer Connection Distribution Block	[A] [B]	A – 31Nm, B – 27Nm	Annually
400A Breaker Panel	[A] [B] [C]	A – 31Nm, B – 5.6Nm, C – 3.9Nm	Annually
Safety Disconnect	[A]	A – 4Nm	Every 3 Years
Power Zone	[A] [B]	A – 2.8Nm, B – 3.6Nm	Every 3 Years
3 Pole distribution block (gutter)	[A] [B]	A – 4Nm, B – Wire pull test	A - Every 3 Years, B – Commissioning only
Grounding Lug (gutter)	[A] [B]	A – 31Nm, B - 3.9Nm	Annually
Skid 480VAC connection	[A]	A 5.1Nm	Annually
Skid Mounting	[A]	A – 203Nm	Every 3 Years

 **Warning**

**Verify All External Power Is Off and
Switches Are in the OFF Position**

9.1.7.2 Torque Reference images

The following identifies the specific location and image description of the components requiring torque checks

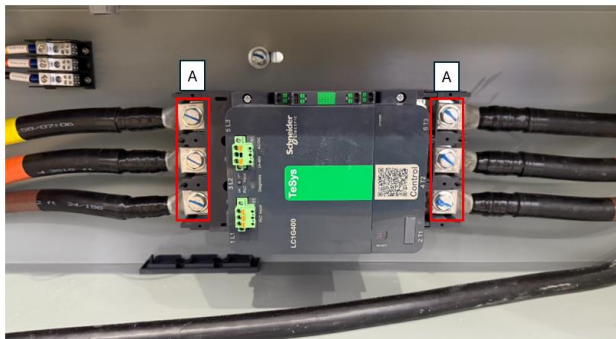
Location (description)	Image
Main Contactor – Electrical room, inside gutter	

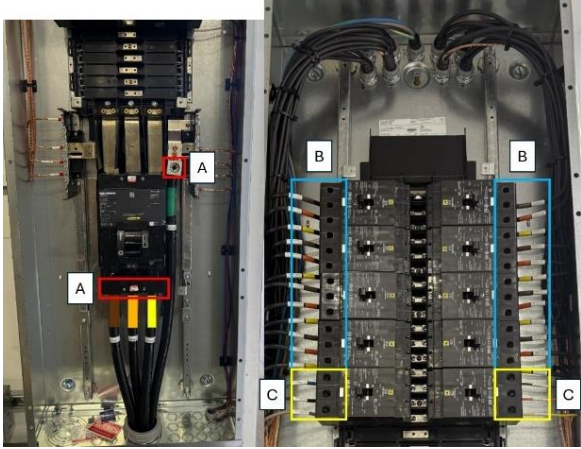
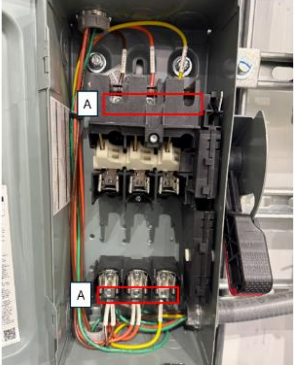
Location (description)	Image
<p>Customer Connection distribution block – Electrical room, inside gutter</p>	
<p>400A panel – Electrical room, RH side. The panel front cover must be removed to access locations</p>	
<p>Disconnect – Electrical room, center</p>	

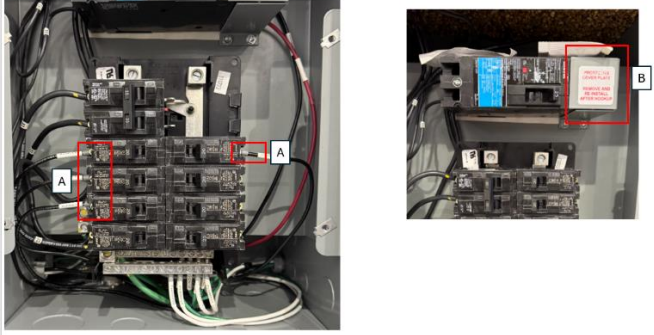
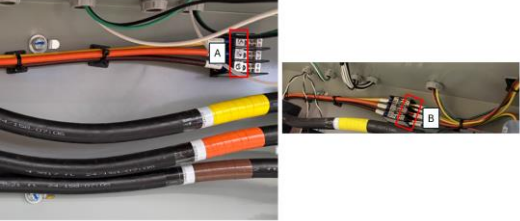
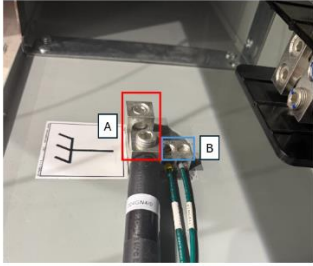
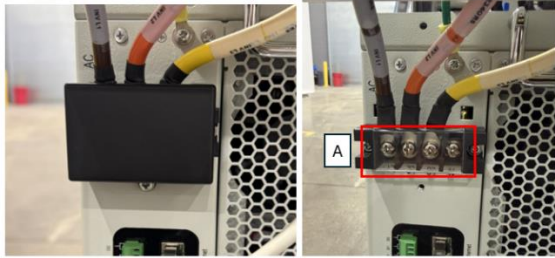
Location (description)	Image
Power Zone – Electrical room, center	
3 Pole distribution block – Electrical room, inside gutter	
Grounding Lug – Electrical room, inside gutter	
Skid 480VAC inverter connection – Battery compartment, behind main skid front cover panel	

9.1.8 Water Intrusion

Visual inspection for water intrusion within unit.

- 1) Open electrical room doors, visually inspect around door openings for water intrusion into the unit. Visually inspect around customer connection panel for water intrusion
- 2) Open all battery compartment doors, visually inspect around door openings for water intrusion into the unit. Visually inspect under, above, and in between each battery skid for any signs of water intrusion. Visually inspect above the HVAC for water intrusion.

If water enters the unit in any location, please contact Viridi customer service. Be prepared to share information about intrusion with customer service including pictures and location of the intrusion.

9.2 Decommissioning

- Contact Viridi first
 - a) Perform 1 final physical inspection (probably mirror the annual inspection less fire and HVAC).
 - b) Lower SOC to 30% SOC.
 - c) Disable fire alarm – after coordination with Viridi and AFP.
 - d) Set Tank to the disabled position
 - e) Go through a shutdown procedure (Reference RPS1200 IOMM)
 - f) Disconnect all exterior/customer connections (Utility connection, ethernet, CANBUS, Fiber connection, etc..).
 - g) Plug / Seal any holes left in the customer connection panel
 - h) Open all Breakers in the power zone and 480V Main Distribution Panel
 - i) Visually Validate everything in the container is powered off

9.3 ViSTA Alarm Definition Glossary

Severity	Description	High Level Definition
Critical	High Impact to Functionality	Anything that can cause the unit, or the "Grid" to shut down Ex. E-stop pressed Ex. Fire Alarm
	Requires Immediate Attention	
Major	High Impact to Functionality	Anything that can cause a skid to go down or a major component to go down. Ex. Inverter alarms or battery DTC alarms
	May not require attention right away	
Warning	Does not impact functionality but if this continues it could cause an alarm	Does not impact on the overall functionality but if this state continues, it will lead to an alarm (either minor, or/and major).

9.4 ViSTA Alarms

Here are some of the common ViSTA alarms, their severity, and a brief explanation along with the action needed to resolve them.

Alarm Name	Severity	Triggered By	Description / Take Action
Main IO (AL1342) Block Comm Failure	CRITICAL	HMI	Communications failure between HMI and main IO block in RPS1200. Contact Viridi Customer Service.
Main 400A Contactor Failure	CRITICAL	HMI	BESS 480VAC contactor position failed. Contact Viridi Customer Service.
E-STOP Activated	CRITICAL	E-STOP	Emergency Stop pressed. Disengage E-Stop and Power Cycle BESS.
Fire Alarm Activated	CRITICAL	AFP Fire Panel	Move people far away from the RPS1200. Contact emergency personnel. Contact Viridi Customer Service.
IO(AL1340) Block 1 Comm Failure!	MAJOR	HMI	Communications failure between HMI and IO block for skids 1-4 in RPS1200 (compartment 1). Contact Viridi Customer Service.
IO(AL1340) Block 2 Comm Failure!	MAJOR	HMI	Communications failure between HMI and IO block for skids 4-8 in RPS1200 (compartment 2). Contact Viridi Customer Service.
EMS Communication Lost	MAJOR	HMI	RPS1200 to Viridi Energy Management System lost. Contact Viridi Customer Service.
ViSTA Connection Lost to Asset	MAJOR	ViSTA Cloud	Communications failure between VCom and ViSTA Cloud. Check wired internet connection (if applicable) and LTE coverage. If an error persists, call Viridi Customer Service.
Skid "X" BMS Temperature Warning	MAJOR	Skid "X" BMS	BMS on Skid X (1 thru #8) senses battery cell temperature too high. Ensure fan filters are clear, HVAC is operational, and BESS is ventilating properly.
Skid "X" BMS Temperature High Error	MAJOR	Skid "X" BMS	BMS on Skid X (1 thru #8) senses battery cell temperature too high. Ensure fan filters are clear, HVAC is operational, and BESS is ventilating properly.
Skid "X" RPS50 Low Pack Voltage	MAJOR	Skid "X" BMS	BMS on Skid X (#1 thru #8) senses battery pack voltage too low. BESS needs to charge Contact Viridi Customer Service.
Skid "X" Inverter AC Bus Over Voltage	MAJOR	Skid "X" Inverter	Inverter on skid X (1 thru #8) senses AC voltage is too high. Check source voltage (can be done through the Deif HMI or ViSTA). If an error persists, call customer service.
Skid "X" Inverter AC Bus Under Voltage	MAJOR	Skid "X" Inverter	Inverter on skid X (1 thru #8) senses AC voltage is too low. Check source voltage (can be done through the Deif HMI or ViSTA). If an error persists, call customer service.
Skid "X" Inverter AC Bus Over Frequency	MAJOR	Skid "X" Inverter	Inverter on skid X (1 thru #8) senses AC frequency is above conformance. Check frequency (can be done through the Deif HMI or ViSTA). If an error persists, call customer service.
Skid "X" Inverter AC Bus Under Frequency	MAJOR	Skid "X" Inverter	Inverter on skid X (1 thru #8) senses AC frequency is below conformance. Check frequency (can be done through the Deif HMI or ViSTA). If an error persists, call customer service.
Skid "X" Inverter AC Bus Phase Reversed	MAJOR	Skid "X" Inverter	Inverter on skid X (1 thru #8) senses AC phase (L1, L2, L3) are in incorrect orientation. Check AC wiring to BESS.
Skid "X" Inverter AC Bus Voltage Asymmetric	MAJOR	Skid "X" Inverter	Inverter on skid X (1 thru #8) senses AC voltage asymmetry. Check source voltage (can be done through the Deif HMI or ViSTA). If an error persists, call customer service.
Skid "X" Inverter AC Bus Voltage Abnormal	MAJOR	Skid "X" Inverter	Inverter on skid X (1 thru #8) senses AC voltage that is too high or too low for operation. Check source voltage (can be done through the Deif HMI or ViSTA). If error persists, call customer service.

Alarm Name	Severity	Triggered By	Description / Take Action
Skid "X" Inverter AC Bus Phase Lost	MAJOR	Skid "X" Inverter	Inverter on skid X (1 thru #8) does not sense AC power. Ensure BESS is in the correct operational mode and that skid level and system level breakers and contactors are closed. If an error persists, call customer service.
Skid "X" Inverter AC Overload Timeout	MAJOR	Skid "X" Inverter	Inverter on skid X (1 thru #8) overload timeout. Load exceeded rated value, code will clear once load is under limit for 5 minutes. If an error persists, call customer service.
Skid "X" Inverter High Temperature Warning	MAJOR	Skid "X" Inverter	Inverter on skid X (1 thru #8) senses internal temperature at AC or DC radiator too high. Ensure fan filters are clear, HVAC is operational, and BESS is ventilating properly.
Skid "X" Inverter High Temperature Error	MAJOR	Skid "X" Inverter	Inverter on skid X (1 thru #8) senses internal temperature at AC or DC radiator too high. Skid offline. Ensure fan filters are clear, HVAC is operational, and BESS is ventilating properly. Skid will not function until inverter temperature drops to a safe threshold.
Skid "X" Inverter High Ambient Temperature Warning	MAJOR	Skid "X" Inverter	Inverter on skid X (1 thru #8) senses ambient temperature too high. Ensure fan filters are clear, HVAC is operational, and BESS is ventilating properly.
Skid "X" Inverter High Ambient Temperature Error	MAJOR	Skid "X" Inverter	Inverter on skid X (1 thru #8) senses ambient temperature too high. Skid offline. Ensure fan filters are clear, HVAC is operational, and BESS is ventilating properly. Skid will not function until inverter temperature drops to a safe threshold.
Skid "X" Discharge Limit Enforcement Fault	MAJOR	Skid "X" PLC	Error code generated by RPS50 Battery Management System [Orion BMS2]. Call Viridi Customer Service. For error code definitions visit https://www.orionbms.com/troubleshooting
Skid "X" Charger Safety Relay Fault	MAJOR	Skid "X" PLC	Error code generated by RPS50 Battery Management System [Orion BMS2]. Call Viridi Customer Service. For error code definitions visit https://www.orionbms.com/troubleshooting
Skid "X" Internal Hardware Fault	MAJOR	Skid "X" PLC	Error code generated by RPS50 Battery Management System [Orion BMS2]. Call Viridi Customer Service. For error code definitions visit https://www.orionbms.com/troubleshooting
Skid "X" Internal Heatsink Thermistor Fault	MAJOR	Skid "X" PLC	Error code generated by RPS50 Battery Management System [Orion BMS2]. Call Viridi Customer Service. For error code definitions visit https://www.orionbms.com/troubleshooting
Skid "X" Internal Software Fault	MAJOR	Skid "X" PLC	Error code generated by RPS50 Battery Management System [Orion BMS2]. Call Viridi Customer Service. For error code definitions visit https://www.orionbms.com/troubleshooting
Skid "X" Highest Cell Voltage Too High Fault	MAJOR	Skid "X" BMS	Error code generated by RPS50 Battery Management System [Orion BMS2]. Call Viridi Customer Service. For error code definitions visit https://www.orionbms.com/troubleshooting
Skid "X" Lowest Cell Voltage Too Low Fault	MAJOR	Skid "X" BMS	Error code generated by RPS50 Battery Management System [Orion BMS2]. Call Viridi Customer Service. For error code definitions visit https://www.orionbms.com/troubleshooting
Skid "X" Pack Too Hot Fault	MAJOR	Skid "X" BMS	Error code generated by RPS50 Battery Management System [Orion BMS2]. Call Viridi Customer Service. For error code definitions visit https://www.orionbms.com/troubleshooting

Alarm Name	Severity	Triggered By	Description / Take Action
Skid "X" High Voltage Interlock Signal Fault	MAJOR	Skid "X" BMS	Error code generated by RPS50 Battery Management System [Orion BMS2]. Call Viridi Customer Service. For error code definitions visit https://www.orionbms.com/troubleshooting
Skid "X" Precharge Circuit Malfunction	MAJOR	Skid "X" BMS	Error code generated by RPS50 Battery Management System [Orion BMS2]. Call Viridi Customer Service. For error code definitions visit https://www.orionbms.com/troubleshooting
Skid "X" Abnormal State of Charge Behavior	MAJOR	Skid "X" BMS	Error code generated by RPS50 Battery Management System [Orion BMS2]. Call Viridi Customer Service. For error code definitions visit https://www.orionbms.com/troubleshooting
Skid "X" Internal Communication Fault	MAJOR	Skid "X" BMS	Error code generated by RPS50 Battery Management System [Orion BMS2]. Call Viridi Customer Service. For error code definitions visit https://www.orionbms.com/troubleshooting
Skid "X" Cell Balancing Stuck Off Fault	MAJOR	Skid "X" BMS	Error code generated by RPS50 Battery Management System [Orion BMS2]. Call Viridi Customer Service. For error code definitions visit https://www.orionbms.com/troubleshooting
Skid "X" Weak Cell Fault	MAJOR	Skid "X" BMS	Error code generated by RPS50 Battery Management System [Orion BMS2]. Call Viridi Customer Service. For error code definitions visit https://www.orionbms.com/troubleshooting
Skid "X" Low Cell Voltage Fault	MAJOR	Skid "X" BMS	Error code generated by RPS50 Battery Management System [Orion BMS2]. Call Viridi Customer Service. For error code definitions visit https://www.orionbms.com/troubleshooting
Skid "X" Open Wiring Fault	MAJOR	Skid "X" BMS	Error code generated by RPS50 Battery Management System [Orion BMS2]. Call Viridi Customer Service. For error code definitions visit https://www.orionbms.com/troubleshooting
Skid "X" Current Sensor Fault	MAJOR	Skid "X" BMS	Error code generated by RPS50 Battery Management System [Orion BMS2]. Call Viridi Customer Service. For error code definitions visit https://www.orionbms.com/troubleshooting
Skid "X" Highest Cell Voltage Over 5V Fault	MAJOR	Skid "X" BMS	Error code generated by RPS50 Battery Management System [Orion BMS2]. Call Viridi Customer Service. For error code definitions visit https://www.orionbms.com/troubleshooting
Skid "X" Cell ASIC Fault	MAJOR	Skid "X" BMS	Error code generated by RPS50 Battery Management System [Orion BMS2]. Call Viridi Customer Service. For error code definitions visit https://www.orionbms.com/troubleshooting
Skid "X" Weak Pack Fault	MAJOR	Skid "X" BMS	Error code generated by RPS50 Battery Management System [Orion BMS2]. Call Viridi Customer Service. For error code definitions visit https://www.orionbms.com/troubleshooting
Skid "X" Fan Monitor Fault	MAJOR	Skid "X" BMS	Error code generated by RPS50 Battery Management System [Orion BMS2]. Call Viridi Customer Service. For error code definitions visit https://www.orionbms.com/troubleshooting
Skid "X" Thermistor Fault	MAJOR	Skid "X" BMS	Error code generated by RPS50 Battery Management System [Orion BMS2]. Call Viridi Customer Service. For error code definitions visit https://www.orionbms.com/troubleshooting
Skid "X" External Communication Fault	MAJOR	Skid "X" BMS	Error code generated by RPS50 Battery Management System [Orion BMS2]. Call Viridi Customer Service. For error code definitions visit https://www.orionbms.com/troubleshooting

Alarm Name	Severity	Triggered By	Description / Take Action
Skid "X" Redundant Power Supply Fault	MAJOR	Skid "X" BMS	Error code generated by RPS50 Battery Management System [Orion BMS2]. Call Viridi Customer Service. For error code definitions visit https://www.orionbms.com/troubleshooting
Skid "X" High Voltage Isolation Fault	MAJOR	Skid "X" BMS	Error code generated by RPS50 Battery Management System [Orion BMS2]. Call Viridi Customer Service. For error code definitions visit https://www.orionbms.com/troubleshooting
Skid "X" Input Power Supply Fault	MAJOR	Skid "X" BMS	Error code generated by RPS50 Battery Management System [Orion BMS2]. Call Viridi Customer Service. For error code definitions visit https://www.orionbms.com/troubleshooting
Skid "X" Charge Limit Enforcement Fault	MAJOR	Skid "X" BMS	Error code generated by RPS50 Battery Management System [Orion BMS2]. Call Viridi Customer Service. For error code definitions visit https://www.orionbms.com/troubleshooting
Skid "X" Max Charge Reached	Warning	HMI	Notification that skids "x" hit the max charge. No action is needed.
Skid "X" Max Discharge Reached	Warning	HMI	Notification that skids "x" hit the max discharge. No action is needed.

9.5 Contact Viridi Customer Service

If an issue is identified with the RPS1200, please contact Viridi Customer Support at 1-866-984-7434

The following information will be requested:

Company Name	
Contact Name and Call Back #:	
Serial Number:	
Set Up Details:	
Fault Details, including history relevant to the fault:	