

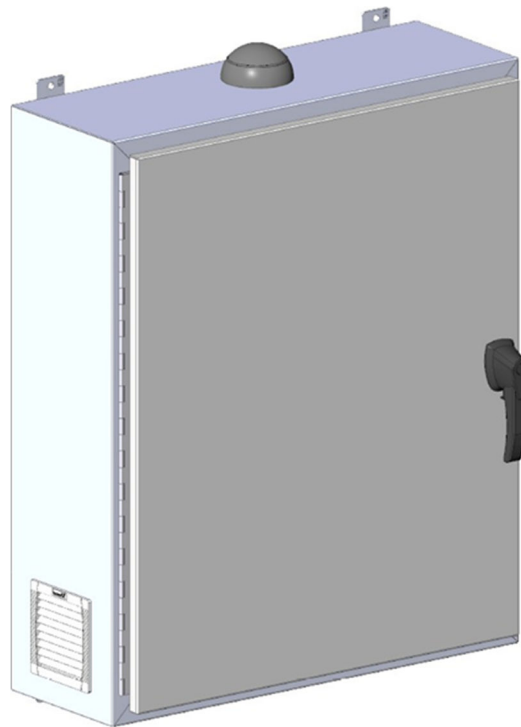

Installation, Operation, & Maintenance Manual



Faveo

(9920-00049)

BACKUP SYSTEM

Revision B: Released 23-JUNE-2026



Contents

- Contents 2
- Document Revision: 3
- 1. Legal Disclaimer..... 4
- 2. Safety 6
 - 2.1 Warnings, Cautions, and Important Notes 6
 - 2.2 Qualified Personnel 7
 - 2.3 Safety Instructions..... 7
 - 2.3.1 Response to Emergency Situations..... 8
 - 2.4 Product Overview 9
 - 2.4.1 Key Benefits..... 9
 - 2.4.2 Specifications..... 9
 - 2.4.3 Physical Dimensioning10
 - 2.4.4 Component Identifier11
 - 2.4.5 Viridi Telematics.....12
 - 2.4.6 MultiPlus 2KVA, 120V Inverter12
 - 2.4.7 MultiPlus Additional Information13
 - 2.4.8 Inverter Specifications.....13
 - 2.4.9 CERBO GX Inverter Controller14
 - 2.4.10 Installation Guide.....15
 - 2.5 Decommissioning16
 - 2.6 Powering the Faveo ON and OFF16
 - 2.6.1 Powering ON.....16
 - 2.6.2 Powering OFF.....17
- 3. Maintenance 18
 - 3.1 Cleaning18
 - 3.2 Air Intake and Exhaust Filter Change19
- 4. Customer Service and Contact Information 21



1. Legal Disclaimer

As an express condition of Viridi's warranty and to encourage utilization of industry best practices, Viridi requires that the installation and operation of the Faveo be only completed by, or at the direction of, a licensed electrical professional (as defined by the jurisdiction(s) within which the installation occurs). Specific installations can vary, so please direct specific questions to Viridi's attention (via telephone: +1 (866) 984-7434; or in writing to service@viridiparente.com). Viridi expressly disclaims liability for installations made in a manner inconsistent with this guide and/or in non-compliance with local building and electrical codes. This user guide incorporates all terms and conditions of sale. All steps, details, and any other information is subject to change, from time to time, with or without notice.



Faveo Installation in Lancaster, New York



Safety, Installation and Handling

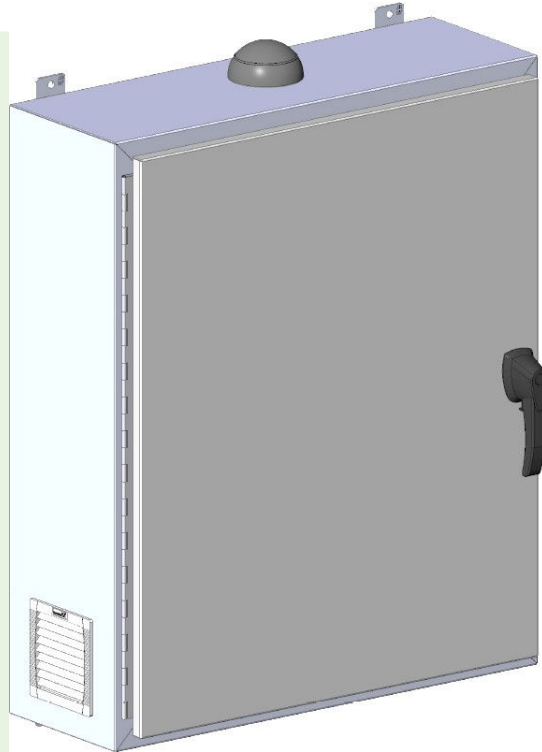

2. Safety

To make the best and proper use of the Faveo Back-up System, this guide to the tasks and procedures described herein is intended for use by skilled staff only. A skilled employee is defined as a trained and qualified electrician or installer with all the following skills and experience:

- Knowledge of the functional principles and operation of on-grid and off-grid (backup) systems
- Knowledge of the dangers and risks associated with installing and using electrical devices and acceptable mitigation methods
- Knowledge of the installation of electrical and electronic devices
- Knowledge of and adherence to this guide and all safety precautions and best practices.
- Knowledge of local installation standards and electrical licenses, if required by local municipality.
- If this Installation, Operations & Maintenance Manual is lost or damaged, order a new one from Viridi Parente, Inc., referencing your equipment serial or asset number.
- Constant efforts are made to improve the quality and performance of our products; it may be that some information in the User Manual differs from your equipment. If any questions arise, please contact Viridi Parente, Inc.
- All the information in this publication is based on the latest product information available at the time of printing. Viridi Parente, Inc. reserves the right to make changes to this Installation, Operations & Maintenance Manual, without notice or obligation.
- No part of this publication may be reproduced or copied without prior written permission from Viridi Parente, Inc.
- Repair or disassembly of the Faveo is only possible by a specially authorized person separately from the installation qualifications.

2.1 Warnings, Cautions, and Important Notes



General Safety Precautions
(By example and without limitation)

All Faveo users and installers are responsible for familiarizing themselves with the contents of this document and all warnings before performing installation and servicing.

This “Safety Alert” symbol and others like it are in place to warn the operator of potential hazards. It means attention/becomes alert – the operator’s safety is involved.

This symbol can signify DANGER and, where used, documents a WARNING or CAUTION which is followed by text highlighting the potential hazard. This manual will detail the potential hazards so that necessary precaution(s) towards ensuring operator and equipment safety.

A **WARNING** signifies a situation whereby the operator, members of staff, or the public could be put in danger of personal injury by the improper operation of the Faveo.

A **CAUTION** signifies a situation whereby damage to the Faveo or associated parts could be caused by improper operation of the unit.

Symbols Used in This Manual

	Warning/Cautions		Quality
	Shock Hazard		Tip
	Minor Shock Hazard		Pull Test
	General Safety		Time
	Wear Gloves		

2.2 Qualified Personnel

This guide for the tasks and procedures described herein is intended for use by skilled staff only. A skilled employee is defined as a trained and qualified electrician or installer with all the following skills, experience and working knowledge of:

- The functional principles and operation of on-grid and off-grid (backup) systems.
- The dangers and risks associated with installing and using electrical devices and acceptable mitigation methods.
- The installation of electrical devices.
- Adherence to this guide and all safety precautions and best practices.
- Local installation standards and electrical licenses, if required by local municipality.

Repair or disassembly of the Faveo is only possible by a specially authorized person separately from the installation qualification

2.3 Safety Instructions

All Faveo users and installers are responsible for familiarizing themselves with the contents of this document and all warnings before performing installation and servicing.



General Safety Precautions (By example and without limitation)

- Over-voltages or incorrect wiring can damage the inverter
- Any type of product breakdown may lead to a leakage of electrolytes or flammable gas
- Avoid installing the Faveo in the same location where flammable materials are stored. Do not install the unit in places where explosive gas or chemicals are present.
- During the installation of the Faveo, the utility grid input must be deenergized. Wiring must be carried out by Qualified Personnel.
- The Faveo should only be serviced by Qualified Trained Personnel.
- The electronics inside the Faveo are vulnerable to electrostatic discharge (ESD).
- Personnel should be grounded before handling the Faveo

Faveo Handling Guide

- Do not expose, place or store the Faveo near highly flammable material or next to an open flame
- Do not expose or place near a water source such as downspouts or sprinklers
- Do not install the Faveo in an airtight enclosure or in an area without ventilation
- The Faveo is a commercial product and not designed for residential installation
- Store the Faveo in a cool, dry place prior to installation
- Store the Faveo on a flat, level surface prior to installation
- Store the Faveo out of reach of children and animals
- Do not disconnect, disassemble, or repair the Faveo with unqualified personnel. Only Qualified Personnel should handle, install, and service the Faveo
- Do not damage the Faveo by dropping, deforming, impacting, cutting, or penetrating with a sharp object. Doing so may cause a fire or leakage of electrolytes.
- Do not step or stand on the Faveo or its packaging
- Do not place any foreign objects on top of the Faveo.
- Do not connect any AC conductors directly to the RPS5 battery assembly. These are only to be connected to the AC-IN / AC-OUT breaker of the Faveo
- Do not charge or discharge the Faveo if damaged
- Install the Faveo with proper clearance from vehicles
- The Faveo has been designed to NEMA 3R, which provides a degree of protection from falling rain, dirt, and sleet, and will be undamaged by the external formation of ice on the enclosure.

Lifting and unpacking guidelines will be dependent on the final consumer and local installation parameters. Follow established workplace safety guidelines and procedures when receiving, handling, transporting, unpacking, lifting, and installing the Faveo.

2.3.1 Response to Emergency Situations

The Faveo includes internal fault mechanisms designed to prevent failures and subsequent risk hazards. However, Viridi cannot guarantee the safe performance of the Faveo if ever exposed to abuse, damage, or negligence.

If an installer or user happens to be exposed to the internal materials of the battery cell due to damage on the outer casing, the following actions are recommended:

- *In Case of Inhalation:* Leave the contaminated area immediately and seek medical attention
- *In Case of Skin Contact:* Wash the contacted area with soap thoroughly and seek medical attention.
- *In Case of Ingestion:* Induce vomiting and seek medical attention
- If a fire breaks out at the location where the Faveo is installed, perform the following counter measures:
 - Utilize fire-extinguishing media as appropriate. Use an FM-200 or CO₂ extinguisher for battery fires. Use of an ABC fire extinguisher if the fire is not from the battery and has not yet spread to it.
 - Follow the proper fire-fighting instructions. If a fire occurs when charging the Faveo, provided it is safe to do so, disconnect the battery pack circuit breaker to shut off the power charge. If the battery pack is not on fire yet, extinguish the fire before the battery pack catches fire, preferably with water. If the battery pack within the Faveo is on fire, do not try to extinguish it, and evacuate people from the premises immediately.





WARNING: Explosion is possible when the battery pack within the Faveo is heated above +150°C. When a battery pack is burning, it will leak poisonous gases. Do not approach it.

- To deal with an accident with the Faveo on land, place the damaged Faveo into a segregated place and call your local fire department or service engineer.
- To deal with an accident with the Faveo in the water, stay out of the water and do not touch anything if any part of the battery, inverter, or wiring is submerged. Do not use the submerged battery, contact your Viridi service engineer for assistance

2.4 Product Overview

2.4.1 Key Benefits

- Instantaneous backup in less than 20 milliseconds
- Improves public safety and security
- Reduces labor costs of controlling or resetting intersection.
- Remote monitoring and full telematics to support data sharing and alerts
- Designed and manufactured to operate in extreme temperatures
- Sophisticated BMS (Battery Management System) with CAN (2.0b).
- BMS performs cell balancing, prevents over/under voltage, current, and pack temperature.
- Maintenance-free for internal electronics; 3-year warranty on all components.

2.4.2 Specifications

<i>Subject</i>	<i>Requirements</i>
Physical:	
Weight	275 lbs. (124.74 kg)
Dimensions	30.5 in wide x 39.2 in tall x 11.4 in deep (without handle) 77.47 cm wide x 99.56 cm tall x 28.95 cm deep (without handles)
Enclosure	Steel NEMA 3R
Operating Temperature Range:	
Discharge	-20°C to 50°C (-4°F to 122°F)
Charge	-20°C to 45°C (-4°F to 113°F)
Notes	Operating temperature range mirrors battery cell specifications. Faveo does not require external thermal management. The Battery Management System is programmed to manage pack utilization rate to control internal pack thermal conditions and prevent operation outside of pack interior temperature limits.
Certifications:	
United Nations Manual of Tests and Criteria	UN 38.3 (cell, module)
Underwriters Laboratory	UL 1642 (cell) UL Recognized UL 2580 (cell) UL Recognized UL 1973 (cell) SGS Listed UL 458 (inverter) SGS Listed

Subject	Requirements
Battery Specifications	Capacity: 196 Ah/5 kWh. Integrated pack fuse: 50kA interrupt rating Integrated contactor: 2000A breaking capacity 250W (2.1A/120V) run time: 20hr 500W (4.6A/120V) run time: 10hr Pack service life: 20-year (~3,000 full cycles)
Recycling Partner	Li-Cycle recovers 95% of the valuable elements in lithium-ion batteries
Note:	Full product sheets and other details can be found at: <ul style="list-style-type: none"> • https://viridiparente.com/products-services/ The Faveo is maintenance-free of internal electronics with a three-year warranty on all components. Failure to adhere to the guidelines set forth in the Faveo: Viridi Backup System USER GUIDE will void the warranty as provided in the terms and conditions of sale.

2.4.3 Physical Dimensioning

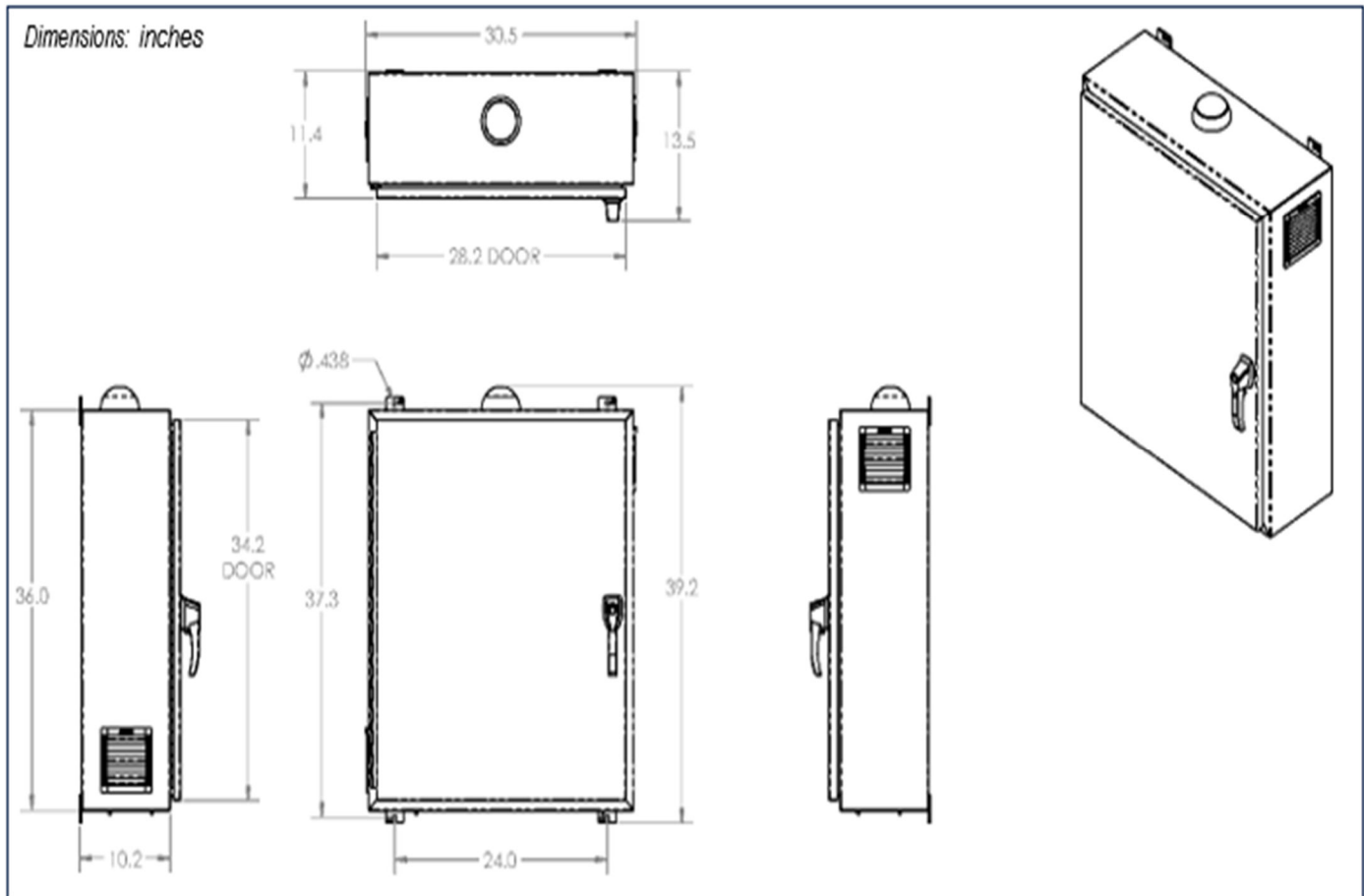

2.4.4 Component Identifier

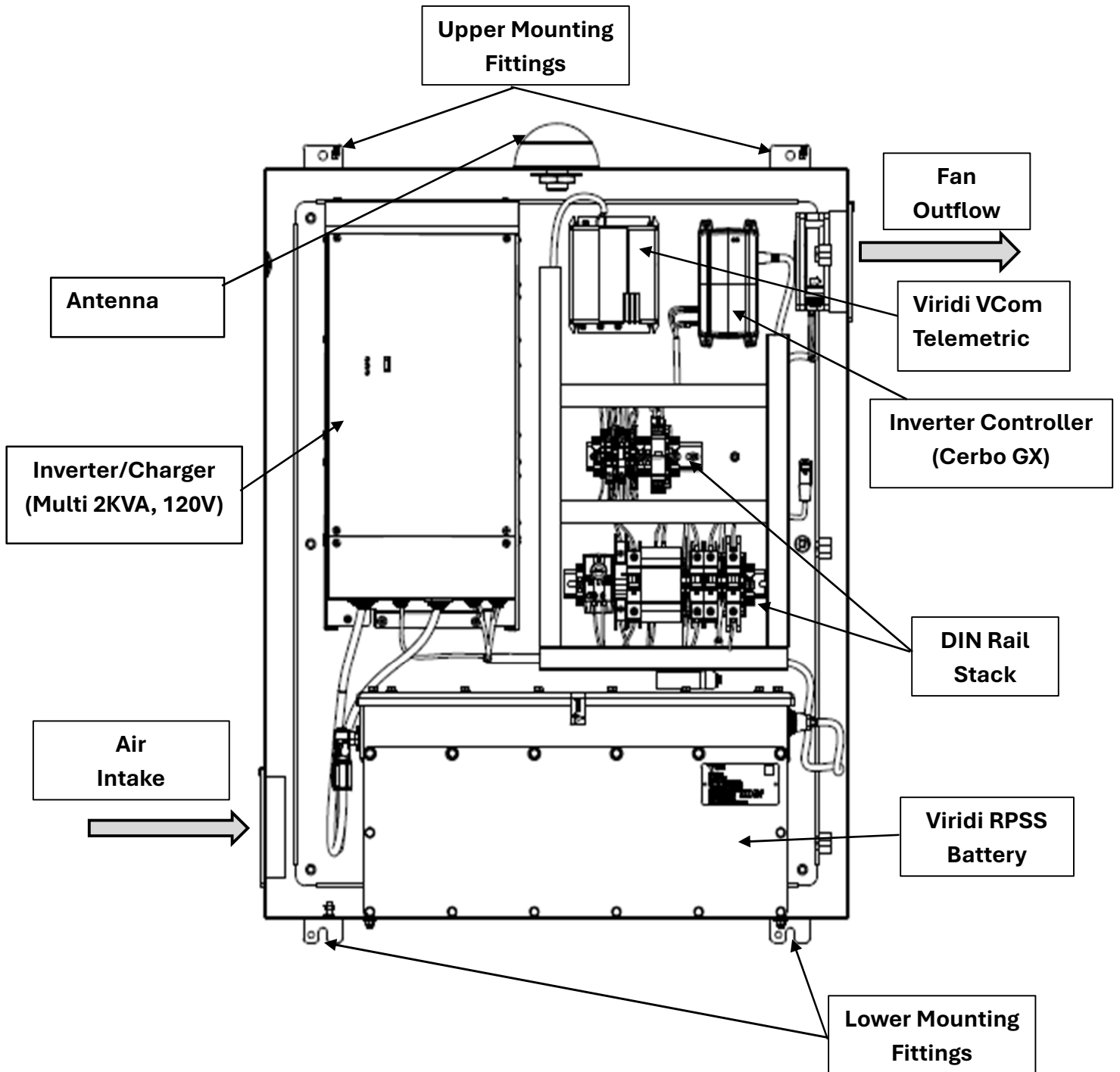

2.4.5 Viridi Telematics

The Viridi VCom telematics unit provides cloud-based monitoring of Faveo data. Access to a data dashboard is customized based on customer needs and can be accessed via the web with a username and password provided upon system installation. Additional Information on the Viridi VCOM is available upon request.



Viridi VCOM

2.4.6 MultiPlus 2KVA, 120V Inverter

The MultiPlus 2kVA 120 V Inverter is an automatic transfer switch and DC to AC inverter to provide an uninterrupted power supply (UPS) to the location where the Faveo is installed.

Key	Definition
A	DIP switch (Cover Removed)
B	ON/OFF/CHARGER Only Switch
C	VE Bus Communications Port
D	Temperature Sensor
E	Alarm Contact
F	Battery Minus
G	Starter Battery Plus
H	Remote Control
I	Mains IN
J	Mains/Converter OUT
K	Battery Plus
M	Earth Connection

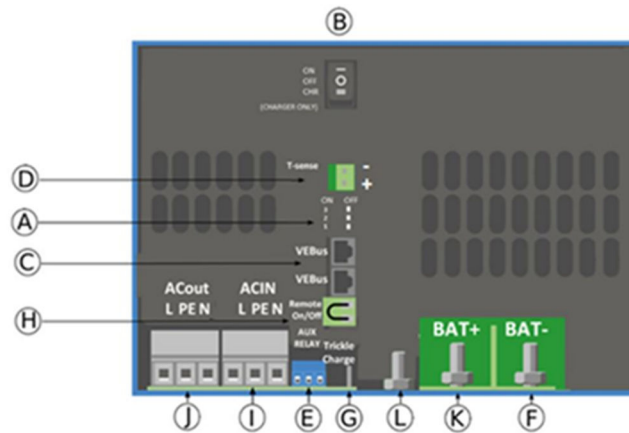

2.4.7 MultiPlus Additional Information

More information on the MultiPlus 2kVA 120V can be found at:

https://www.victronenergy.com/upload/documents/MultiPlus_2kVA_120V/24547-MultiPlus_2kVA-pdf-en.pdf



2.4.8 Inverter Specifications

Inverter Specifications	
Category	MultiPlus 24/2000/50
Power Control / Power Assist	Yes
Transfer Switch	50A
Inverter	
Input Voltage Range	19 Vdc to 33 Vdc
Output Voltage	120 Vac, $\pm 2\%$
Output Frequency ⁽¹⁾	60 Hz $\pm 0.1\%$
Continuous Output Power at 25°C (77°F) ⁽³⁾	2000VAC
Continuous Output Power at 25°C (77°F)	1600W
Continuous Output Power at 40°C (104°F)	1400W
Continuous Output Power at 65°C (149°F)	1000W
Peak Power	3500W
Maximum Efficiency	94%
Zero-Load Power	11W
Zero-Load Power Search Mode	4W
Charger	
AC Input Voltage Range	94 Vac to 140 Vac
AC Input Frequency Range	55 Hz to 65 Hz
Charge Voltage absorption	28.8 V
Charge voltage "Float"	27.6 V
Storage Mode	26.4 V
Charge Current House Battery ⁽⁴⁾	50 A
Charger Current Starter Battery	1 A
Battery Temperature Sensor	Yes
General	
Programmable Relay ⁽⁵⁾	Yes
Protection ⁽²⁾	2a to 2g
Operating Temperature	-40°C to +65°C (-40°C to +140°F) fan assisted cooling
Humidity	Maximum 95%, non-condensing

Inverter Specifications	
Enclosure	
Material and color	Steel/ABS, Blue RAL 5012
Protection Category	IP 21
Battery Connection	M8 Bolts
230 V AC Connection	Screw Terminal. 13mm ² (6 AWG)
Weight	15.5kG (34.2 lbs.)
Dimensions (H x W x D)	506 mm x 236 mm x 147 mm (19.92-inch x 9.29-inch x 5.79-inch)
Standards	
Safety	EN-IEC 60335-1, EN-IEC 60335-2-29, EN 62109-1
Emission / Immunity	EN 55014-1, EN 55014-2, EN-IEC 61000-3-2, EN-IEC 61000-3-3, IEC 61000-6-1, IEC 61000-6-2, IEC 61000-6-3
Road vehicles	ECE R10-4
Notes	
<p>1) Can be adjusted to 50Hz, except for the 24V model.</p> <p>2) Protection:</p> <ol style="list-style-type: none"> a. Output short circuit b. Overload c. Battery voltage to high d. Battery voltage to low e. Temperature to high f. 230Vac on inverter output g. Input voltage ripple to high <p>3) Non-linear load, crest factor 3:1</p> <p>4) Up to 25°C (77°F) ambient</p> <p>5) Programmable relay which can be set for:</p> <ul style="list-style-type: none"> • General Alarm, DC under voltage or generator start/stop • AC rating: 230V/4A • DC rating: 4A up to 35Vdc, 1A up to 60Vdc 	

2.4.9 CERBO GX Inverter Controller

The Cerbo GX Inverter Controller interfaces between the BMS (Battery Management System) and the inverter to control the settings of the Faveo.



Cerbo GX Inverter Controller

Additional information on the Cerbo GX can be found at:

https://www.victronenergy.com/upload/documents/Cerbo_GX/140558-CCGXVenusGXCerboGXCerbo-S_GX_Manual-pdf-en.pdf



2.4.10 Installation Guide

1. Mount the Faveo to the desired surface.
 - a) The unit is pole-mounted to the intersection infrastructure where grid power is located.
 - b) Mounting options include, but are not limited to strap-mounts, bolts, and Unistrut. This includes mounting against multiple surfaces, including light poles, traffic poles, or on a solid wall.
2. Run conduit from the Faveo to the power source provided.
 - a) 1 inch conduit is recommended to allow for additional equipment or systems such as cameras, data collection devices, etc. However, ½ inch conduit may also be used if there are no other power needs.
 - b) The power source is often located on the pole (or area) where the Faveo is mounted (1.a).
3. Connect line (black), neutral (white), and ground (green) wires directly from the Faveo to the provided power source into the surge suppressor corresponding to Faveo wiring. Left to right should be Neutral (1), Ground (PE), Line (5).
 - a) Line, neutral, and ground wires are labeled inside the Faveo.
 - b) In some areas, line, neutral, and ground wires may be connected through a new or existing transfer or generator plug switch to bypass the Faveo system. This allows for system service without interrupting power.

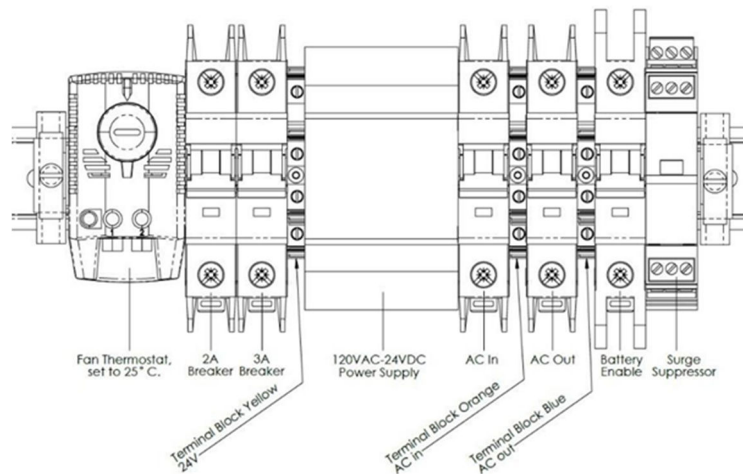

Primary Power Interface

4. Set all the switches inside the Faveo to the ON position. It takes about 30 seconds for all components to power up. Verify the inverter switch is in the ON position.
5. Once the unit is powering the traffic light and traffic is safely controlled, test the system by turning the AC In breaker to the OFF position. Traffic lights should function without interruption. Turn the AC In breaker back to the ON position.
6. Finally, turn the Battery Enable breaker to the OFF position. Traffic lights should again remain on with no interruption. Turn the Battery Enable breaker back to the ON position.
7. Test data connection to Viridi and client monitoring (processes vary based on location and client preference).

2.5 Decommissioning

To decommission or uninstall the Faveo please contact your Viridi service team. Decommissioning must be completed by Qualified Personnel. Disposal of components requires compliance with local laws, rules, and regulations. Viridi encourages recycling of all materials where possible and works with LiCycle to recover valuable lithium-ion battery components.

Required equipment, tools, and other items depend on consumer requirements and installation location. Consult your service engineer and local installer for further instruction. Mounting hardware is not included. The Faveo is a commercial product and is not designed for residential installation.

2.6 Powering the Faveo ON and OFF

2.6.1 Powering ON

1. Open the enclosure door.
2. Ensure all breakers are off and wires are all securely connected.
3. Re-energize utility grid power.
4. Turn ON the Battery Enable Breaker.
5. Turn ON (Engage) the AC In breaker.
6. Turn ON (Engage) the AC Out breaker.
7. Turn ON (Engage) the remaining 2A and 3A breakers.
8. Indicator lights on the inverter, Cerbo GX, and AC-DC converter should illuminate.
9. After approximately 30 seconds, the Inverter light changes from Inverting to Charging.
10. Close and verify the enclosure door is secured.



2.6.2 Powering OFF

1. Open the enclosure door.
2. Turn OFF (Open) the AC Out Breaker.
3. Turn OFF (Open) the AC In Breaker.
4. Turn OFF (Open) the Battery Enable Breaker.
5. Turn OFF (Open) the remaining 2A and 3A breakers.
6. The System is OFF but be aware Utility Grid power is still present at AC In breaker input.
7. Close and verify the enclosure door is secured.

3. Maintenance

Note:

- FAVEO must be completely disconnected from all external connections prior to any maintenance.
- For part numbers or replacement information, contact service@viridiparente.com or parts@viridiparente.com

3.1 Cleaning

While every effort has been made to ensure the accuracy of the content, the authors and publishers make no warranties, either express or implied, regarding the completeness or reliability of the information contained herein. Under no circumstances shall the authors, publishers, or any affiliated parties be liable for any direct, indirect, incidental, consequential, or punitive damages arising from the use or inability to use the information in these guidelines, even if advised of the possibility of such damages. By using this document, you agree to these terms and conditions.

- DO NOT power-wash any part of the unit
- DO NOT spray any part of the unit (with a hose or other cleaning instruments)
- DO NOT touch the battery caps or high-voltage electrical connections
- Hand wash user and electrical interface panels with an all-purpose cleaner and rag
- Hand wash outside top, front, and side panels, with soapy water and sponge



WARNING

To prevent electric shock, Arc Flash, or equipment damage, all power sources must be safely disconnected and de-energized before performing any internal maintenance on the Battery Energy Storage System (BESS).

For part numbers or replacement information, contact: service@viridiparente.com or parts@viridiparente.com

3.2 Air Intake and Exhaust Filter Change

1. To Change the Intake & Exhaust air filter(s), take the following steps:
 - a. Unlatch the air filter cover
 - b. Carefully remove the filter
 - c. Wipe or vacuum the filter housing to remove excess dust, dirt or debris
 - d. Do not spray water or cleaning liquids at or near the filter housing
 - e. Replace the filter with a new clean filter
 - f. Secure and verify the plastic filter housing is secure
2. Filter Part Number (pack of qty=5)
 - a. Pfannenberg Fan Filter Part Number: PF2000-11720004055
 - b. Viridi Part Number: 1000-00178
3. Contact References:
 - a. parts@viridiparente.com
 - b. service@viridiparente.com for replacements

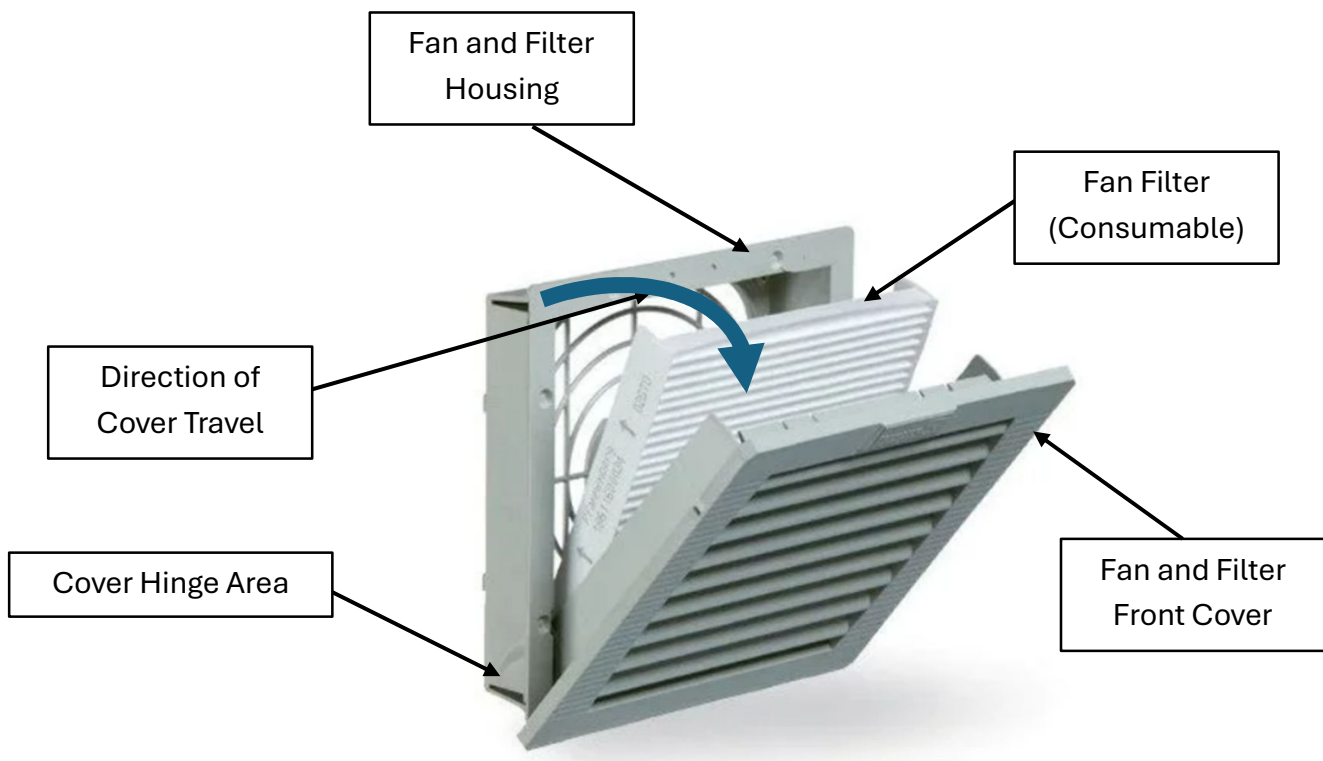

Fan Filter Access

4. Maintenance Schedule:

- a. Check filters for blockages, dust, and/or debris every 3-6 months.
- b. Replace filters every 1-3 years. Replacement of filters may be required more often at the customers' discretion if the unit is located in high dust content areas.

5. Locations of filter housings:

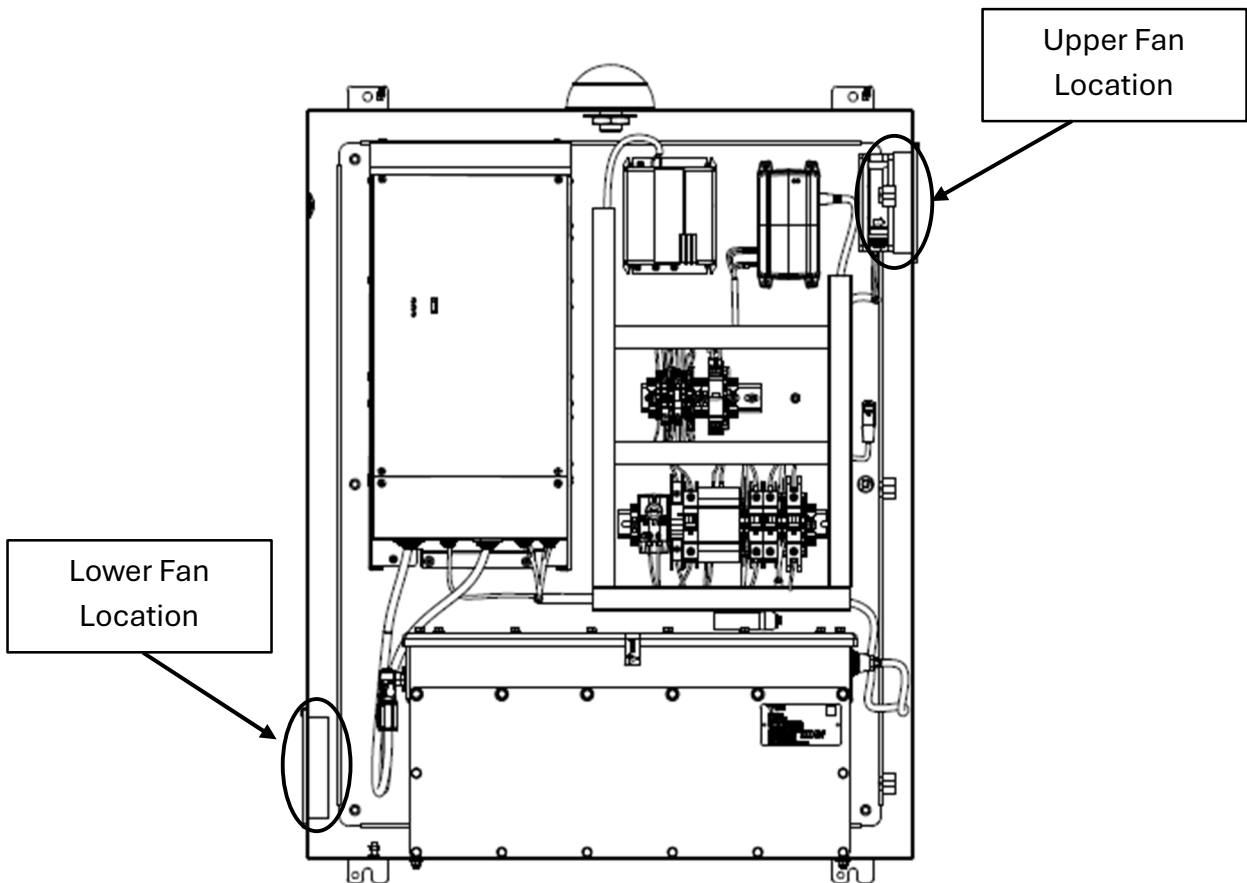

Upper and Lower Fan Locations

Note: The main door access of the Faveo unit does not need to be opened for filter service/replacement. Image is only meant to aid in locating filter housing locations.

4. Customer Service and Contact Information

Address	Viridi Parente, Inc. 1001 East Delavan Avenue, Suite 02 Buffalo, NY 14215
Contact	Phone: +1 (866) 984-7434 Email: service@viridiparente.com
Business Hours	Monday – Friday 8:30am to 4:30pm Eastern Time
Website	www.viridiparente.com



Aerial View of Viridi at 1001 East Delavan Avenue

