



Viridi RPS150

POINT-OF-USE ENERGY STORAGE SOLUTIONS

Trailer Mounted Battery Energy Storage System

KEY BENEFITS

- Zero emissions
- On-Grid Charging
- Off-Grid Discharging
- On-Grid Discharging
- Generator Hybridization Operation
- Micro-Grid Forming & Participation
- Minimal Noise

DISCHARGE PARAMETERS ¹

- Minimum to maximum operating temperature: -10°C to 45°C (14°F to 113°F)
- Max continuous power: 30 kW

CHARGE PARAMETERS ²

- Minimum to maximum operating temperature: -10°C to 45°C (14°F to 113°F)
- Max continuous power: 30 kW

PHYSICAL PARAMETERS

- RPS150 Length (excl trailer) 100.7 in
- RPS150 Width (excl trailer) 44.8 in
- RPS150 Height (excl trailer) 65.4 in
- RPS150 Skid Mounted Unit Weight 5,750 lbs
- Trailer Mounted Weight 7,000 lbs

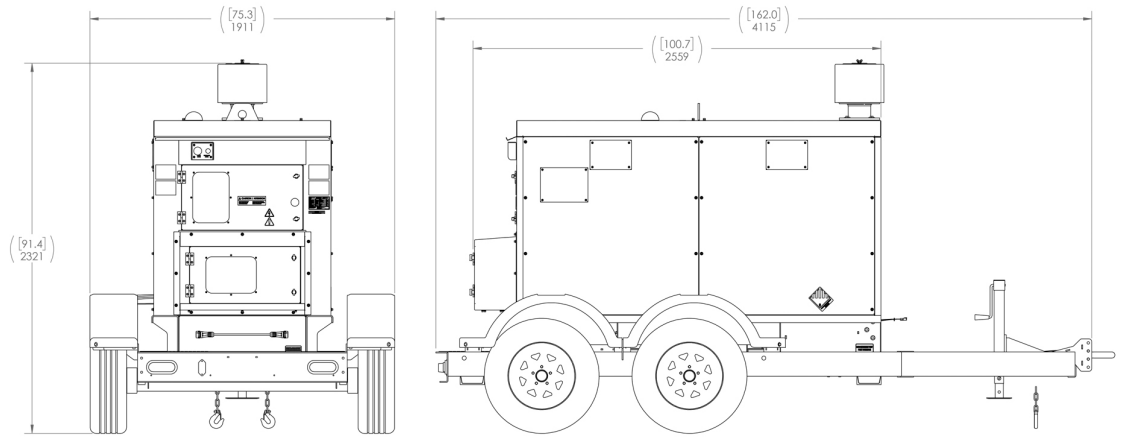

ELECTRICAL FEATURES

- 2 X AC Cam-Locks SWITCHABLE
208V | 3PH | 83.4A
480V | 3PH | 36.1A
400V | 3PH | 43.3A
- 1 X NEMA 14-50R
208 V | 1PH | 50A
- 2 X CS Twist Lock Receptacles
208 V | 1PH | 50A
- 2 X NEMA 5-20R
120V | 1PH | 20A

MECHANICAL FEATURES

- Skid-Based Design
Compatible Towable Trailers
- Side-Access Fork-Lift Pockets
- Single-Top Lift Point
- Full Custom Enclosure
44 X 50 X 90 Inches

PARALLELING OPERATION

- Parallel with other RPS150 units
- Parallel with other “DEIF” controlled paralleling generators
- Total paralleling capability of up to 16 systems for 480kW of power and 2.4MWh of total capacity

PERFORMANCE

Max Continuous Power¹

- 30kW Charge
- 30kW Discharge

Battery System

- 146.7 kWh Nominal
- 132 kWh Usable
- 3,000 Cycles at Usable Capacity³

CERTIFICATIONS

- UN 38.3 (cell/module)
- UL 1642 (cell)
- UL 1973 cETLus Recognized
- UL 9540A (cell/module/pack tested)
- UL 9540 (field evaluated at full ESS level)
- All Electrical Components are UL Certified

¹ Operating temperature range mirrors battery cell specifications. The Battery Management System (BMS) is programmed to manage the pack utilization rate to control the internal pack thermal conditions and prevent operation outside of pack interior temperature limits, which can be tailored for different applications/installations. The BMS communicates applicable operating conditions continuously via CAN bus to the inverter and/or system controller.

² Optimal minimum to maximum charge operating temperature: 0°C to 40° C. For charging below -0°C maximum charge rate: 13.8kW.

³ Cycle life can be optimized for individual applications and operating conditions (depth of discharge, duty cycle, temperature, charge/discharge rate).

FOR MORE INFORMATION

sales@viridiparente.com
716.968.8658